

HPSTAR 150-09 EM

N°	Référence NAV	Désignation NAV	QUANTITE
1	HPSTAR100-010	CHASSIS	1
2	ZREDZ60	ROUE DIAM 260 INCREVABLE	2
3	ZGOUN-D20	CALOTTE D20	2
4	ZPLOT-CAOU-M6-D30	PLOT CAOUTCHOUC M6 D30 L38 H11	2
5	ZCONTACTM6I	RONDELLE MOYENNE M6 INOX	10
6	ZECROUBAGM6I	ECROU BAG NYLON M6 INOX	10
7	HPSTAR100-020	BRANCARD	1
8	HPSTAR100-200-300-01	PORTE FLEXIBLE	1
9	ZVISBHCHEIM6X16	VIS BHC M6*16 EMBASE INOX	8
10	ZVISPHM3,5X9,5	VIS 3,5*9,5 ZIN AUTOTARAUDEUSE	2
11	ZCABL-SECU	CABLE SECURITE DIA 1,5	2
12	ZGOUPEAUT4,5X36	GOUPILLE AUTO 4,5X36 MM	2
13	KA-10.15-230V2,9KW	POMPE AXIALE ELEC 150-10	1
14	ZVSTHMH8X25.1	VIS TH M8*25 INOX	4
15	ZPLATEM8M1	RONDELLE MOYENNE M8 INOX	8
16	ZECROUM8I	ECROU HU M8 INOX	4
17	HPSTAR100-050	CAPOT ELEC 150-10EM	1
18	ZTUYAUPVC2	TUYAU PVC DN6	1
19	ZFILT-DETER-D6-8	FILTRE DETERGENT DIA6-8	1
20	ZPIST-EXT-22-MF-22	PISTOLET + RALLONGE 350BAR	1
21	ZLANCE-D-F22-250	LANCE DOUBLE 250BAR	1
22	ZFLEX-1-10M-210	FLEXIBLE 10M 1 T 210B M22X1,5F	1
23	ZBUSE-HP-03525	BUSE HP NPT M1/4 CERAMIC 03525	1
24	ZBUSE-BP-5040	BUSE BP NPT M1/4 5040	1

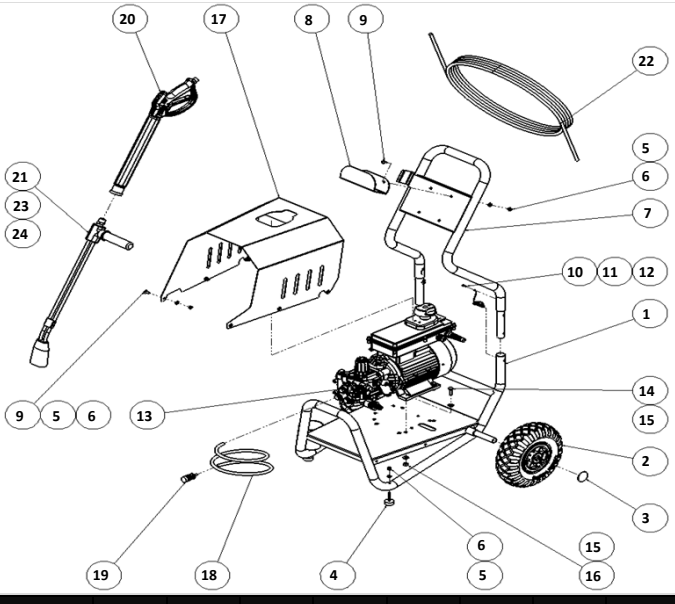

KA-10.15-230V2,9KW

N°	REF. COMET	DESCRIPTION	QUANTITE
1	28030435	Chem. Coupling Kit	1
2	18020180	Detergent Spring	1
3	30030026	Ball	1
4	28030424	Chem. Coupling	1
5	32020018	Cap (G1/8")	1
6	36090014	Screw (M8x55)	1
7	32180327	Manifold	1
8	12200058	Suct./Del. Valve Ass.y kit	6
9	12100049	O-Ring (Ø1,78x12,42)	6
10	30090170	Valve Seat	6
11	36040028	Suct./Del. Valve	6
12	18020227	Suct./Del. Valve Spring	6
13	12050037	Suct./Del. Valve Cage	6
14	06010273	Spacer	2
15	12100151	O-Ring (Ø1,78x17,17)	6
16	32020236	Plug	6
17	24090089	Piston (Ø14)	3
18	18020153	Spring	3
19	00090221	Ring	3
20	00090220	Ring (Ø14)	3
21	12100429	O-Ring (Ø3x92)	1
22	00010480	Eccentric Shaft (9°30')	1
23	04360017	Axial Bearing (Ø45x65x14)	1
24	28160088	Thrust Bearing	1
25	36090005	Screw (M8x20)	1
26	18170064	Knob	1
27	12150584	Regulation Valve Ass.y (140 bar)	1
28	36090005	Screw (M8x20)	4
29	32010027	Oil Indicator (G1/2")	1
30	12100048	O-Ring (Ø2,62x20,24)	1
31	32000071	Plug	1
32	04030135	Pump Crankcase	1
33	32000096	Cap (G1/4")	1
34	12090117	Seal (Ø13x20x2)	1
35	00190058	Oil Seal (Ø14x22x5/7)	3
36	06010308	Oil Seal Spacer	3
37	12410057	Packing (Ø14x22x4)	3
38	12100356	O-Ring (Ø1,78x25,12)	3
39	00090219	Packing Retainer	3
40	00090369	Ring	3
41	12410059	Packing	3
42	24090091	Check Valve Kit	1
43	12100460	O-Ring (Ø2,4x4,3)	1
44	24090086	Check Valve	1
45	18020197	Spring	1
46	34100311	Injector Body Kit (M22x1,5)	1
47	12100040	O-Ring (Ø1,78x15,6)	1
48	12100049	O-Ring (Ø1,78x12,42)	1
49	32000007	Cap (G3/8")	1
50	32020018	Cap (G1/8")	1
51	32000017	Plug (G1/8X8)	1
52	20000105	Nipple	1
53	10020132	Water Foltter	1
54	28030325	Quick Coupler	1
55	28110127	Copper Washer (Ø14x18x1,5)	1
56	28120081	Detergent Washer	1
57	18020207	Spring	1
58	01110006	Total Stop rod Kit	1
59	12100227	O-Ring (Ø1,78x5,25)	1
60	00090110	Ring (Ø1,78x6,07)	1
61	00150200	Rod	1
62	12100146	O-Ring (Ø1,78x2,9)	1
63	00090202	Ring	1
64	36050117	Special Screw	1
65	09022900	Ring	1
66	24160112	Switch Protection	1
67	30010538	Total Stop Box	1
68	12010137	Gasket (PG11)	1
69	12000056	Ring Nut (PG11)	1
70	04560264	Total Stop cable (MNF/TRF)	1
71	36250048	Screw	3
72	04020200	Cover	1
73	12010136	O-Ring (Ø2x118,5)	1
74	18250016	Total Stop Switch	1
75	12020066	"H" Hook	1
76	06080030	Easy Start cap	1
77	18160100	Gauge	1

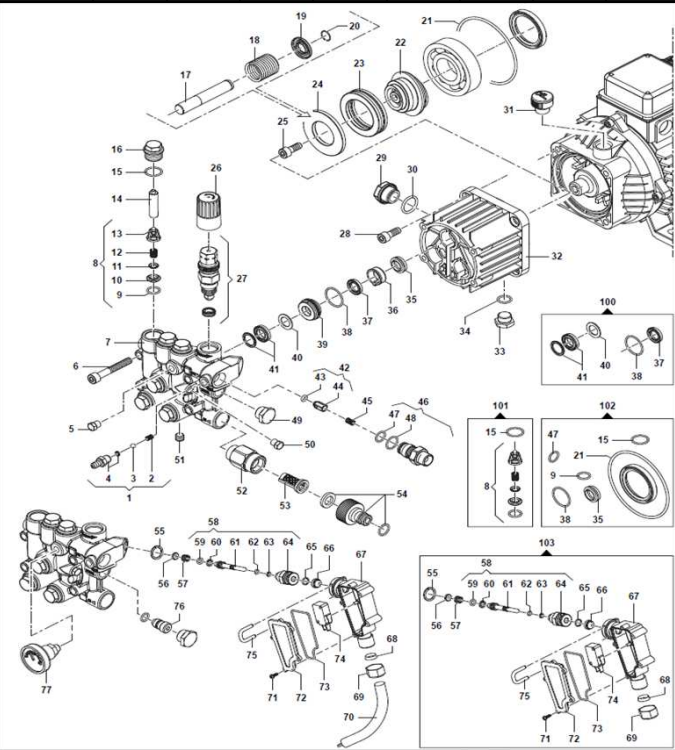

Electrical part

1	32020281	Cap	1
2	18170069	Knob	1
3	00090263	Ring	1
4	04020245	Cover	1
5	12010143	Electrical Box Gasket	1
6	06010292	Spacer	1
7	12100394	O-Ring (Ø2x25)	1
8	30030007	Ball	1
9	18020195	Spring (Wire Ø1 "Ø8x16"	1
10	16000079	Switch Lever	1
11	30010149	Electrical Box (PG 11)	1
12	36250052	Screw (M4,8x13)	4
13	14100061	Switch (16A)	1
14	04180044	Switch Holder	1
15	36050154	Special Screw (Ø4x25)	6
16	24340027	Cable Holder (PG11)	1
17	04560286	Electrical Cable (3Gx2,5)	1
18	12270028	Ring Nut (PG 11)	1
19	12270028	Ring Nut (PG 11)	1
20	24340036	Cable Holder (PG11)	1
21	36090041	Screw	4
22	04020261	Fan Cover	1
23	36320071	Fan Kit	1
24	12410070	Seal	1
25	36250042	Screw (3,9x6,5)	4
26	10090192	Rear Flange	1
27	00090275	Ring	1
28	04380086	Ball Bearing	1
29	30410158	Stator Kit	1
30	00010474	Rotor Shaft	1
31	0460033	Cover	1
32	30020539	Front Flange	1
33	00190034	Oil Seal (Ø40x55x7)	1
34	04380076	Ball Bearing (Ø40x80x18)	1
35	36090041	Screw (M6x25)	4
36	12010127	Electrical Box Gasket	1
37	18310419	Electrical Motor (MNF230V 50Hz 3CV)	1
38	16100787	Electrical Diagram (MNF)	1
39	24340062	Cable Holder (M22x1,5)	1
40	24340052	Cable Holder (M20x1,5)	1
41	36250036	Screw (4,8x13)	4
42	04020264	Electrical Box	1
43	12100345	O-Ring (Ø1,78x101,32)	1
44	36250052	Screw (4,8x13)	4
45	10030075	Capacitor Holder	1
46	04340021	Condenser (50µF)	1
47	32250088	Contacteur (12A 400V)	1

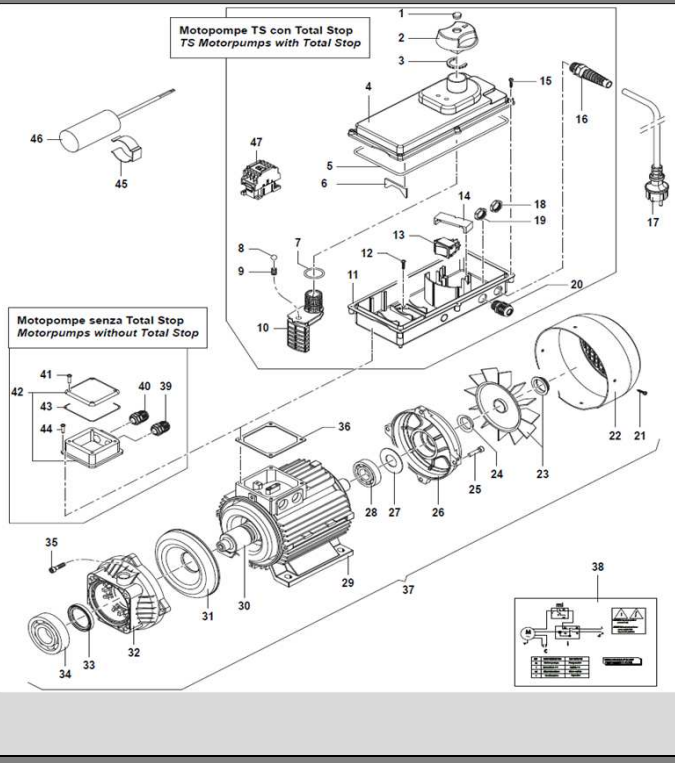

PART KIT

100	50190078	Water Seal Kit	1
101	50250014	Valve Kit	1
102	50190079	Oil Seal Kit	1
103	31030023	Complete total Stop Kit (MNF)	1