

HPSTAR 150-13

N°	Référence NAV	Désignation NAV	Quantité
1	HPSTAR100-010	CHASSIS	1
2	ZRED260I	ROUE DIAM 260 INCREVABLE	2
3	ZGOUN-D20	CALOTTE D20	2
4	ZPILOT-CAOU-M6-D30	PLOT CAOUTCHOUC M6 D30 L38 H11	2
5	ZCONTACTM6I	RONDELLE MOYENNE M6 INOX	4
6	ZECROUBAGM6I	ECROU BAG NYLON M6 INOX	4
7	HPSTAR100-020	BRANCARD	1
8	HPSTAR100-200-300-01	PORTE FLEXIBLE	1
9	ZVISBHCEIM6X16	VIS BHC M6*16 EMBASE INOX	2
10	ZVISPHM3,5X9,5	VIS 3,5*9,5 ZIN AUTOTARAUEUSE	2
11	ZCABL-SECU	CABLE SECURITE DIA 1,5	2
12	ZGOUAUT4,5X36	GOUPILE AUTO 4,5X36 MM	1
13	EX170DT0053	SP170 DULSH NOIR	1
14	HP150-13-KITPOMPE	KIT POMPE HPSTAR 150-13	1
15	ZVISCHCS/16X25 I	VIS CHC 5/16*25 UNC INOX	4
16	ZGROWERM8 I	RONDELLE GROWER M8 INOX	4
17	MER-909328	PLOT A 3030 M8 15 X 35	4
18	ZPLATEM8M I	RONDELLE MOYENNE M8 INOX	8
19	ZECROUM8 I	ECROU HU M8 INOX	8
20	ZGRILLEECHAP-01	GRILLE DE POT EX17 DUL	1
21	ZTUVAUPVC2	TUYAU PVC DN6	1
22	ZFILT-DETER-D6-8	FILTRE DETERGENT DIA6-8	1
23	ZPIST-EXT-22-MF-22	PISTOLET + RALLONGE 350BAR	1
24	ZLANCE-D-F22-250	LANCE DOUBLE 250BAR	1
25	ZFLEX-1T-10M-210	FLEXIBLE 10M 1 T 210B M22X1,5F	1
26	ZBUSE-HP-04025	BUSE HP NPT M1/4 CERAMIC 04025	1
27	ZBUSE-BP-5040	BUSE BP NPT M1/4 5040	1
14	HP150-13-KITPOMPE	KIT POMPE HPSTAR 150-13	
14-a	SJV-3.5G27-D	POMPE AXIALE 150-13	1
14-b	ZFILT-1/2-FM-1/2	FILTRE EAU NHP FM G1/2	1
14-c	ZRACC-JARD-M1/2	RACCORD A BILLE MALE G1/2	1
14-d	ZMANO-D50-AR-250	MANOMETRE D50 G1/4 AR 0-250	1

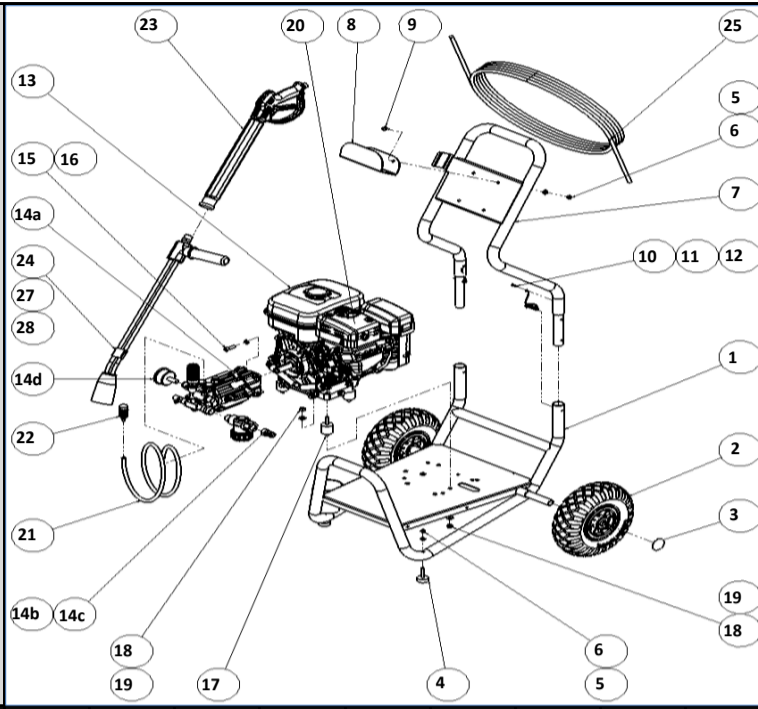

SJV-3.5G27-D

N°	REF. ANNOVI	DESCRIPTION	QUANTITE
1	1981780	MANOPOLA	1
2	1980300	DADO M6 UNI 5589 6S Z/B	1
3	1980470	GRANO M6x20 UNI 5923 INOX A2-70	1
4	1980390	INSERTO MANOPOLA ALTO CON FORO SPINA	1
5	1080070	SPINA 2,5x10 UNI 1707 INOX	2
6	1980220	PIATTELLO MOLLA	2
7	1271070	MOLLA De 10,8x48,9x2,8 IN CATAFORESI	1
8	1080041	PISTONE SUPERIORE	1
9	1080401	ANELLO ANTIEST. IN TEFLON	1
10	1080250	OR 7,66x1,78 85 Sh-A(RIF.2031)	1
11	1980210	GUIDA PISTONE	1
12	880830	OR 15,54x2,62 75 Sh(RIF.3062)	7
13	740290	OR 14x1,78(RIF.2056)	1
14	800560	OR 8,73x1,78(RIF.108)	1
15	1271170	ANELLO ANTIESTRUS. 6,5x3,7x1	1
16	1080190	OR 2,90x1,78(RIF.2012)	2
17	1271160	PISTONE INFERIORE	1
18	1980200	SEDE VALVOLA	1
19	1470210	OR 9x1	1
20	880581	TAPPO 1/4"G	2
21	820510	OR 10,82x1,78(RIF.2043)	2
22	620301	TAPPO 1/8"GAS CONICO	1
23	1980310	VITE TCEI M10x6S UNI 5931 Z/B	3
24	650530	RONDELLA ZIGRINATA 10,5x16x1 Z/B	3
25	1982450	TESTA POMPA PER SJ	1
26	1260162	TAPPO VALVOLA	3
27	960160	OR 17,86x2,62(RIF.123)	3
28	1269050	VALVOLA COMPLETA SERIE 126/132	3
29	1982520	PORTAGOMMA D.8	1
30	480480	OR 4,48x1,78(rif.2018)	1
31	1250280	SFERA INOX AISI 420 7/32"	1
32	1560520	MOLLA De 4,55x6,5x0,25	1
33	1460430	OR 4x2,5	1
34	1540170	OTTURATORE DIAM.10 NICHELATO	1
35	1080091	MOLLA De 6,5x14x0,5	1
36	394280	OR 12,42x1,78(RIF.2050)	1
37	1200690	OR 15,6x1,78(RIF.2062)	1
38	1270141	INIETTORE DETERGENTE 3/8"GAS MARC 2(D.2)BICONO NUOVO PROFILO	1
40	1980950	VALVOLA COMPLETA SERIE 198	3
41	1342761	GUARNIZIONE DM 25x15x5/3 PARK VEDI DIS.	3
42	1981570	GUIDA PISTONE D.15	3
43	770260	OR 23,52x1,78(RIF.2093)	3
44	1260440	GUARNIZIONE C1 15x22x5,5	3
45	1981580	ANTIESTRUSORE D15xDe25	3
46	1980410	ANELLO TENUTA WIPER 15x24x5(SIDAT)	3
47	770090	OR 5,28x1,78(RIF.2021)	1
48	1983050	CORPO POMPA(1 FORO 3/8"GAS)	1
49	740290	OR 14x1,78(RIF.2056)	1
50	1980380	TAPPO DI SFIATO OLIO CON OR E SACCHETTO CON CERNIERA	1
53	180030	VITE TCEI M8x20 UNI 5931 Z/B	4
54	1981140	MOLLA De 28x62,5x2,5	3
55	1981120	PISTONE D.15x73 FLAMMATO	3
56	1980150	ANELLO PER MOLLA	3
57	1983100	RALLA 60x23x6	1
58	1980250	GABBIA ASSIALE AXK 4060	1
59	1980240	RALLA AS 4060	1
61	1982840	ALBERO PER XI CON FORO 3/4"(INCL.10?)	1
63	1980340	OR 83,8x2,62	1
64	1981420	FLANGIA POMPA ORIZZONTALE	1
65	1982360	CUSCINETTO 35x72x17 7207B	1
66	1140380	ANELLO TENUTA 30x42x7 BA	1
67	1980430	DISTANZIALE PER ANELLO DI TENUTA	3
77	1981130	PIATTELLO APPOGGIO PISTONE D.15x73	3
78	1981770	TAPPO MANOPOLA	1
79	1122260	NIPLES M22X1,5(M)3/8"GAS(F)	1

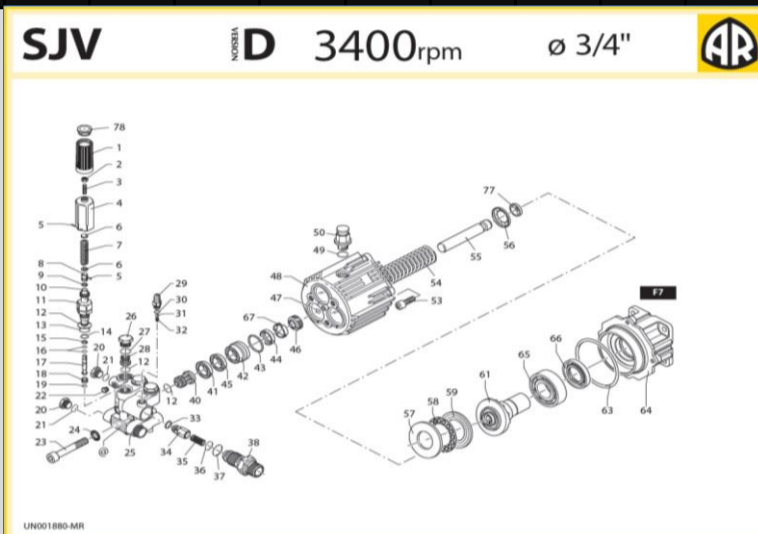

38

79

PART KIT

KIT A			
12			6
28	2869	valves	3
40			3
KIT B			
55	2513	pistons Ø15	3
KIT C			
12			3
28	2591	oil seals	1
40			1
KIT E			
41			3
43	2167	water seals Ø15	3
44			3
45			3
KIT F			
9			1
10			1
12			7
13			1
14			1
15			1
16			2
19			1
21			2
27	2799	O-Rings	3
30			1
31			1
32			1
33			1
36			1
37			1
49			3
63			1

