



PARTS CATALOG

Model
EX21

Engine Model
EX210DH5167

30-01-2023

GROUP INDEX

Group Name	Page
CRANKCASE GROUP	4
CRANKSHAFT GROUP	6
INTAKE and EXHAUST GROUP.....	8
GOVERNOR GROUP	12
COOLING and STARTING GROUP	14
FUEL, LUBRICATION GROUP	18
CARBURETOR GROUP	20
ELECTRIC DEVICE GROUP	22
ACCESSORY GROUP	26

INDEX OF DESCRIPTION SYMBOLS			
SYMBOL	DESCRIPTION	SYMBOL	DESCRIPTION
AY	ASSEMBLY	P=	PITCH (in mm)
CP	COMPLETE	P.T.O. (PTO)	POWER TAKE OFF
EX	EXPORT (from Japan)	REF.	REFERENCE
FIG.	FIGURE	R.H. (RH)	RIGHT HAND SIDE
FR.	FRONT	RR.	REAR
"	INCH	STD.	STANDARD
INCL.	INCLUDE	SW	SWITCH
~L	LITER	T=	THICKNESS (in mm)
L=	LENGTH (in. mm)	UN	UNIT
L.H. (LH)	LEFT-HAND SIDE	U.S.	UNDER SIZE
MECH	MECHANICAL	~V	VOLTAGE
NO (NON)	NONE	~W	WATT
OPT	OPTIONAL	W/	WITH
O.S.	OVER SIZE	W/O	WITHOUT

FIG. 300 INTAKE and EXHAUST GROUP

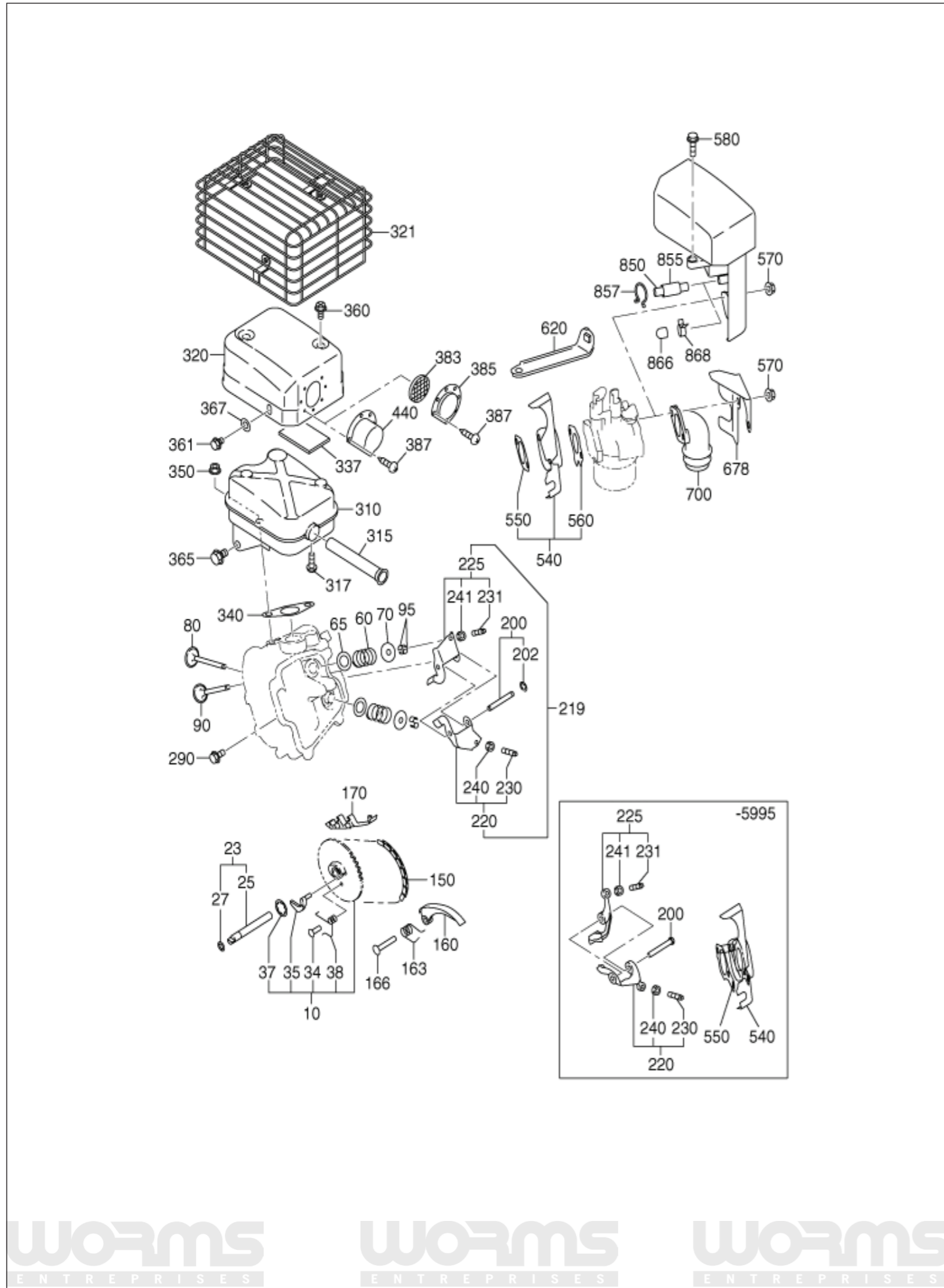

FIG. 300 INTAKE and EXHAUST GROUP

REF.	PART NUMBER	PART NAME	QTY.	REMARKS
10	20A3160101	CAM SHAFT CP	1	85DX2.9B N=40
23	20A3510101	PIN(CAM SHAFT) CP	1	
27	20A0280100	O RING	1	5.8DX9.6D
60	20A3360103	VALVE SPRING	2	19.2DX2.3DX27.4L
70	20A3370103	SPRING RETAINER	2	
80	20A3340103	INTAKE VALVE	1	25.5DX5.5DX68.1L
90	20A3350103	EXHAUST VALVE	1	23.5DX5.5DX68.1L
95	20A3380103	COLLET-VALVE	4	
150	21D3560101	TIMING CHAIN CP	1	92 LINK
160	20A3691103	TENTIONER	1	
163	20A3710103	SPRING(TENTIONER)	1	10DX1.8DX14L N=4.5
166	20A3690203	PIN(TENTIONER)	1	6DX13DX34L
170	20A3691303	CHAIN GUIDE	1	
200	20A3500401	PIN(ROCKER) CP	1	
202	20A0321100	CLIP	1	5DX11DX0.6T
220	20A3620100	ROCKER ARM(IN) AY	1	
225	20A3620200	ROCKER ARM(EX) AY	1	
290	20A0111100	FLANGE BOLT	1	M6X1.0X14DX12L
310	20A3010111	MUFFLER CP	1	
320	20A3420101	MUFFLER COVER CP	1	
340	20A3520103	GASKET(MUFFLER)	1	T=0.2 26D 9DX58P
350	20A0185120	FLANGE NUT	2	M8X1.25X17DX7.5H
360	20A0120100	TAPPING BOLT	2	M6X13DX10L
361	20A0111200	FLANGE BOLT	1	M6X1.0X14DX8L
365	20A0110400	FLANGE BOLT	1	M8X1.25X16DX12L
367	20A0210100	WASHER	1	
387	20A0140200	TAPPING SCREW	2	M4X6L
440	20A3700111	DEFLECTOR CP	1	
540	20A3290201	INSULATOR CP	1	
550	20A3590303	GASKET 2(INSULATOR)	1	T=0.5
560	20A3590203	GASKET 1(INSULATOR)	1	T=0.5
570	20A0185200	FLANGE NUT	2	M6X1.0X13DX6H
580	20A0111300	FLANGE BOLT	1	M6X1.0X13DX20L
850	20A0811100	BREATHER PIPE	1	8DX11DX104L

www.wormsentreprises.com



Siège social / Head Office

ZAC de Lamirault
39 rue de Lamirault, 77090 Collégien, FRANCE
TEL. +33 (0) 1 64 76 29 50
FAX +33 (0) 1 64 76 29 99

Services commercial et Pièces de rechange

Sales and Spare Parts Departments
TEL. +33 (0) 1 64 76 29 60
FAX +33 (0) 1 64 76 29 99