



WORMS
E N T R E P R I S E S

PARTS CATALOG

Model
EX30

Engine Model
EX300DSH522

14-09-2021



GROUP INDEX

Group Name	Page
CRANKCASE GROUP	4
CRANKSHAFT GROUP	6
INTAKE and EXHAUST GROUP.....	8
GOVERNOR GROUP	12
COOLING and STARTING GROUP	14
FUEL, LUBRICATION GROUP	18
ELECTRIC DEVICE GROUP	20
ACCESSORY GROUP	28

INDEX OF DESCRIPTION SYMBOLS			
SYMBOL	DESCRIPTION	SYMBOL	DESCRIPTION
AY	ASSEMBLY	P=	PITCH (in mm)
CP	COMPLETE	P.T.O. (PTO)	POWER TAKE OFF
EX	EXPORT (from Japan)	REF.	REFERENCE
FIG.	FIGURE	R.H. (RH)	RIGHT HAND SIDE
FR.	FRONT	RR.	REAR
"	INCH	STD.	STANDARD
INCL.	INCLUDE	SW	SWITCH
~L	LITER	T=	THICKNESS (in mm)
L=	LENGTH (in. mm)	UN	UNIT
L.H. (LH)	LEFT-HAND SIDE	U.S.	UNDER SIZE
MECH	MECHANICAL	~V	VOLTAGE
NO (NON)	NONE	~W	WATT
OPT.	OPTIONAL	W/	WITH
O.S.	OVER SIZE	W/O	WITHOUT

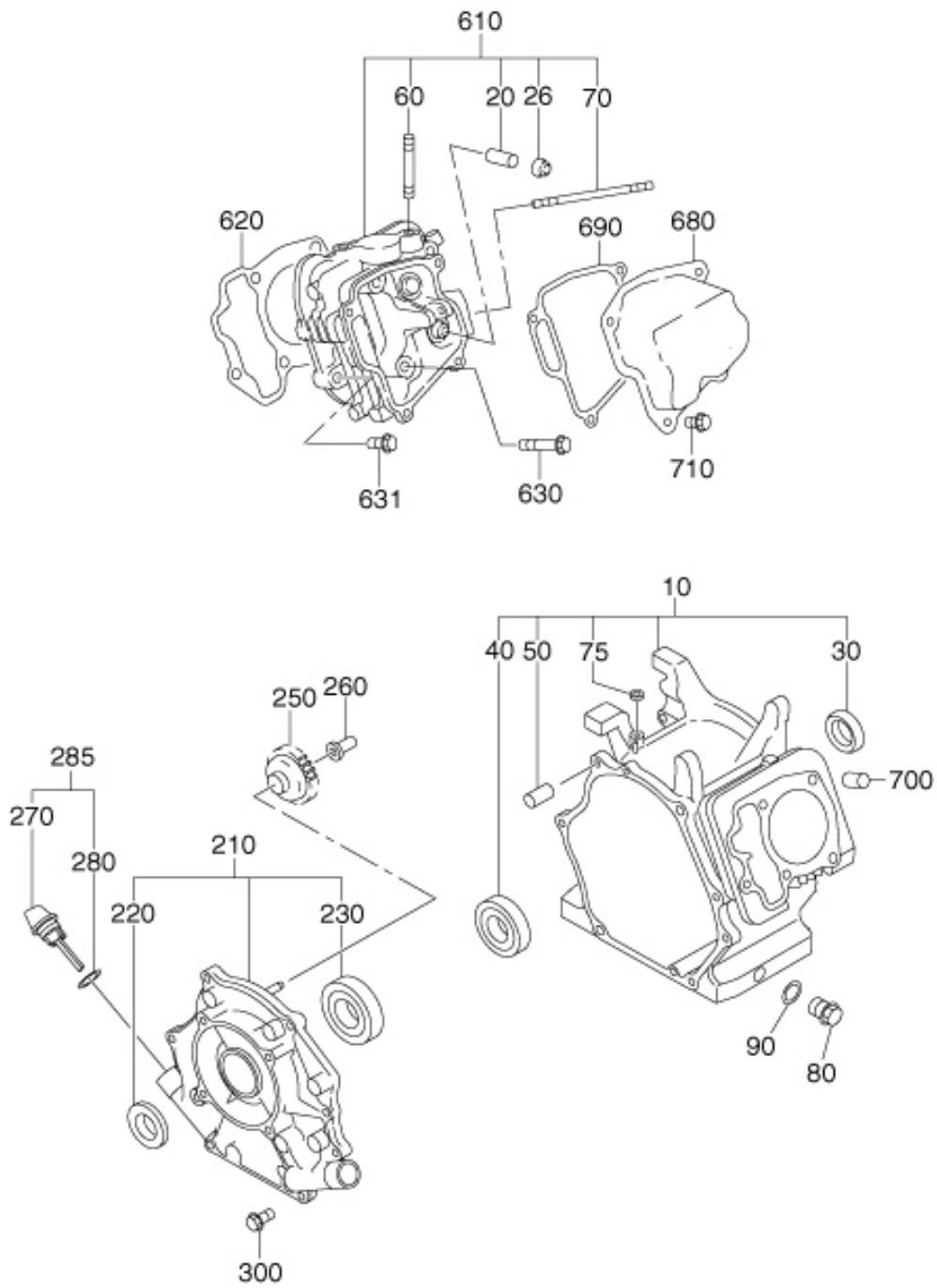

960- GASKET SET

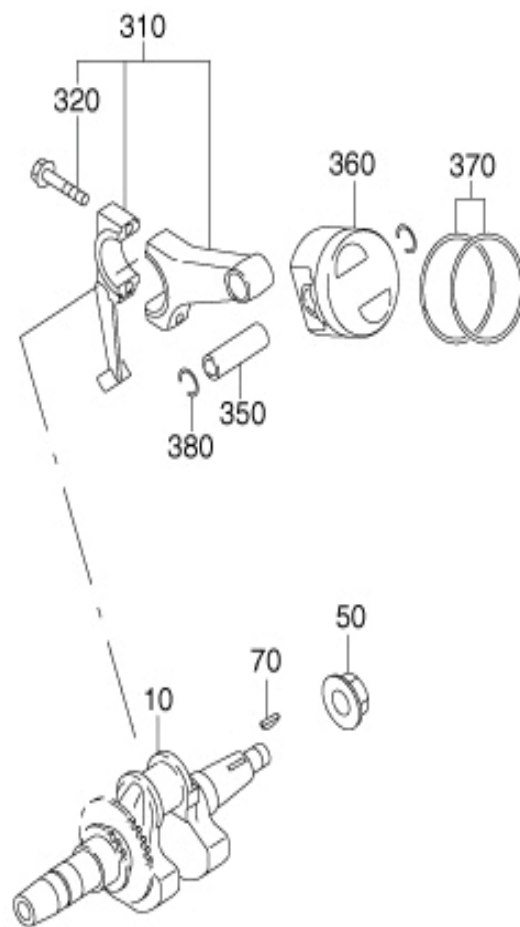

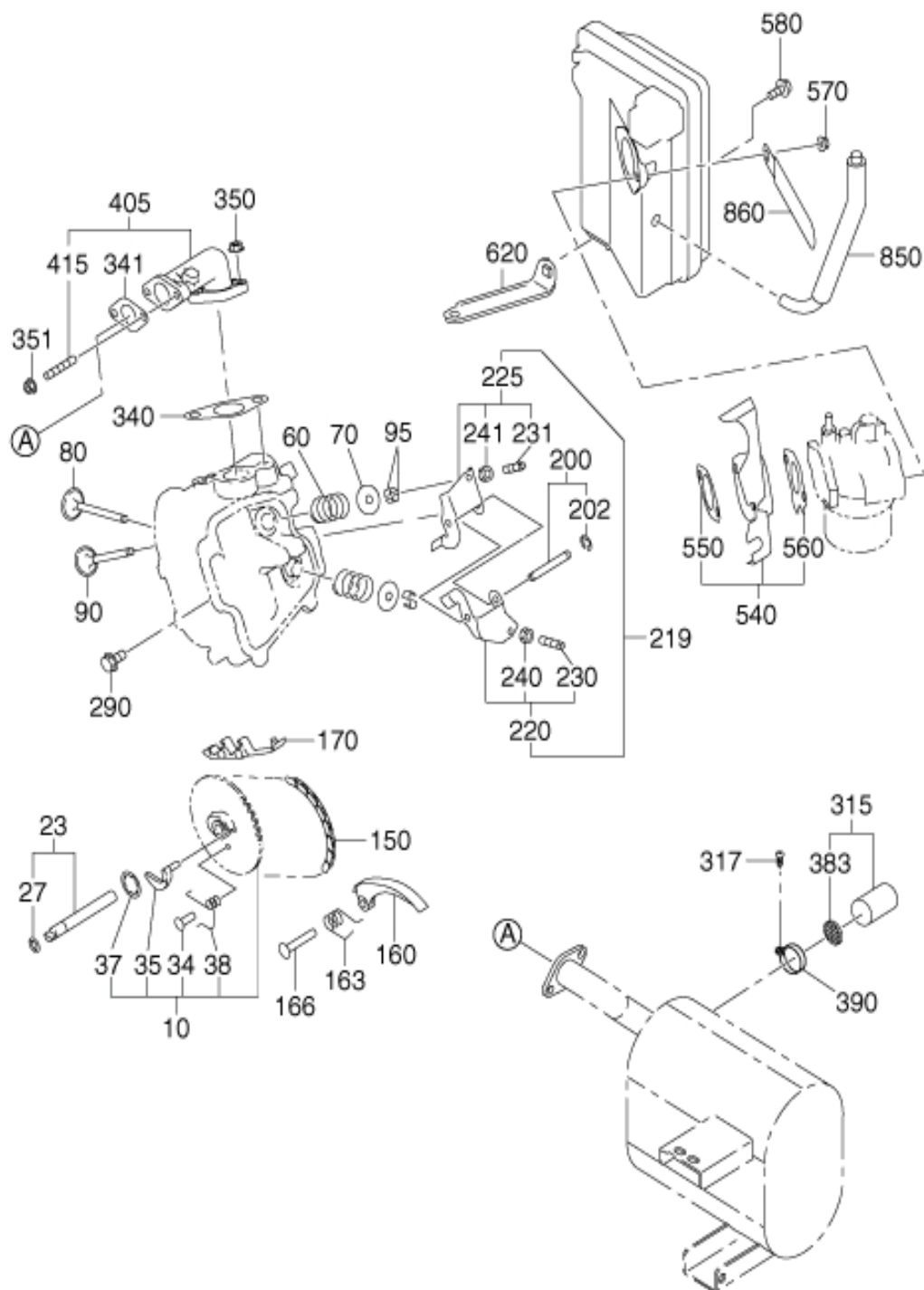

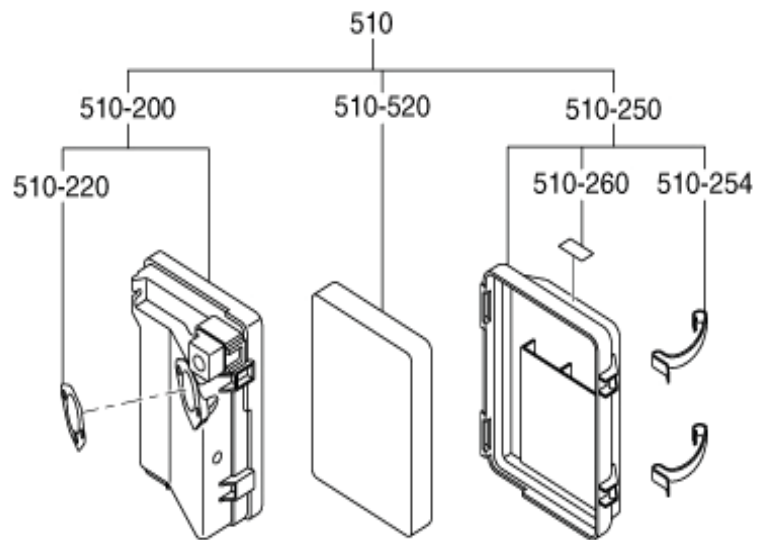

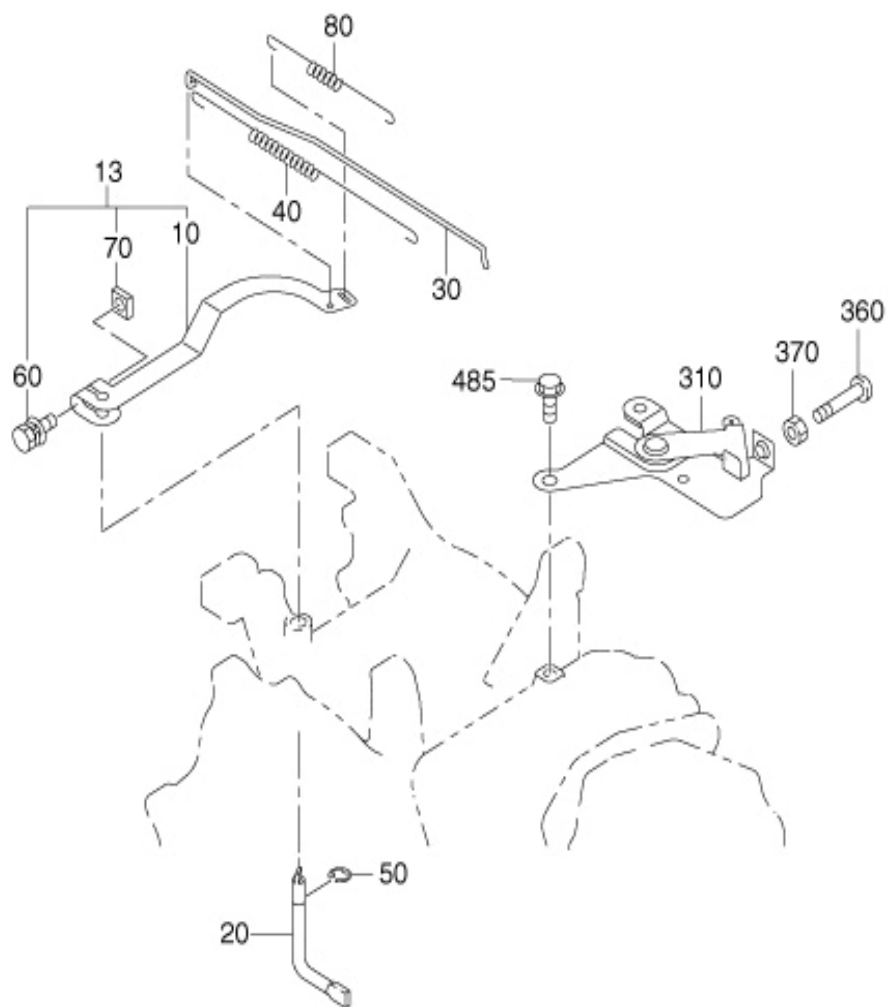

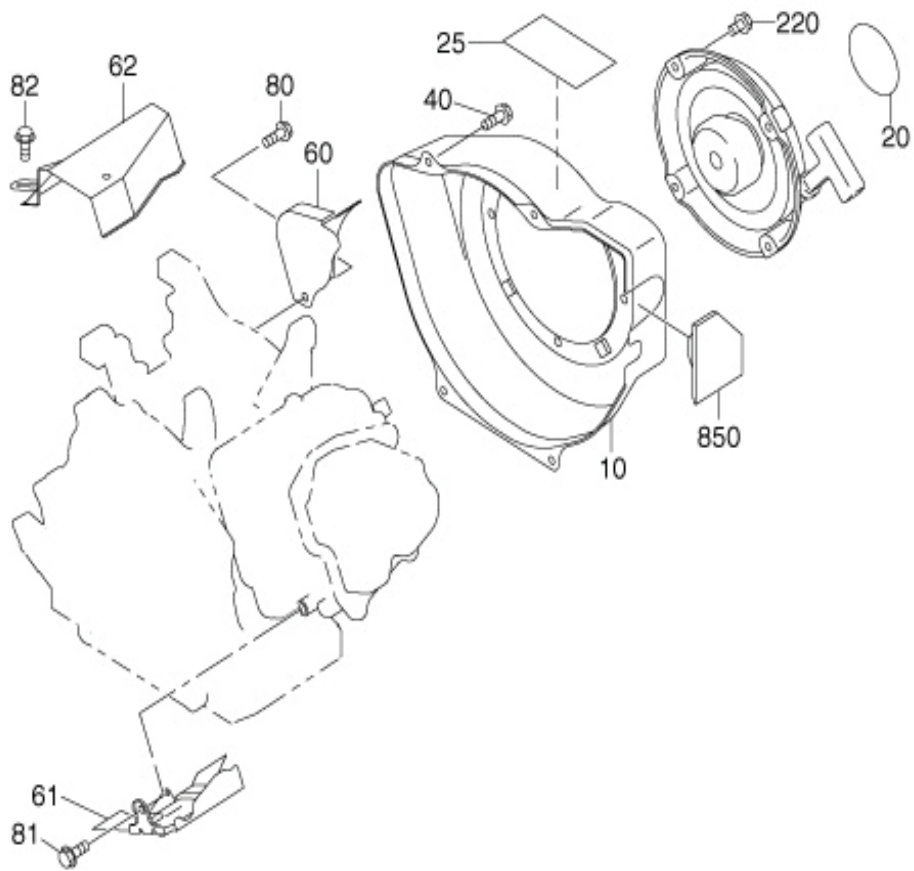

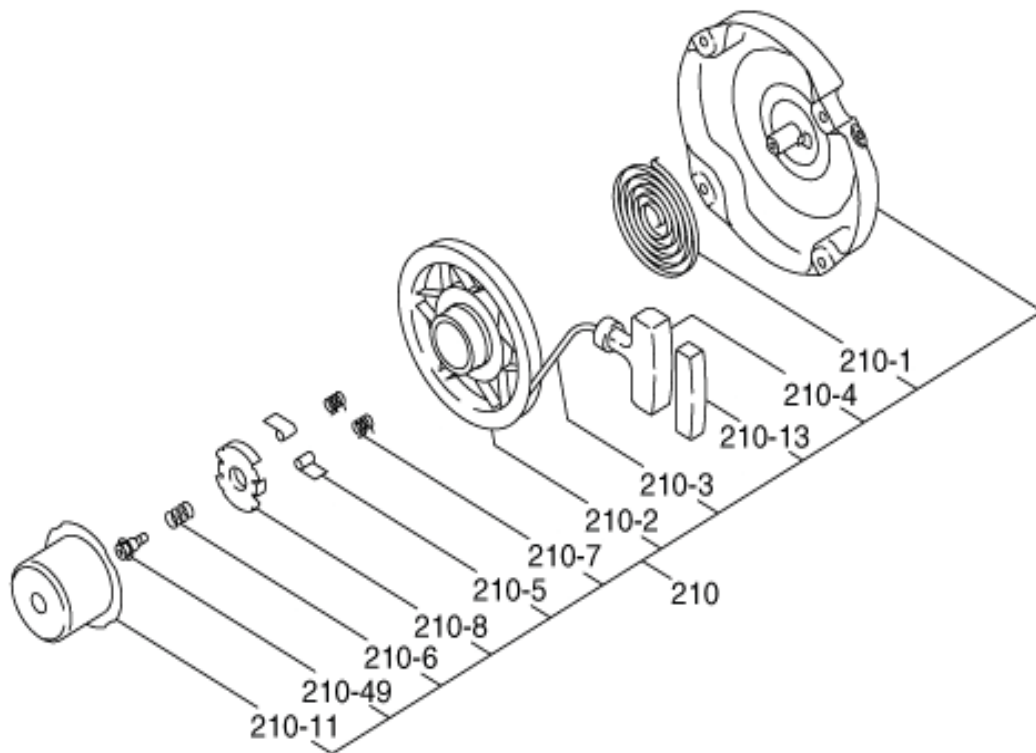

RESIN

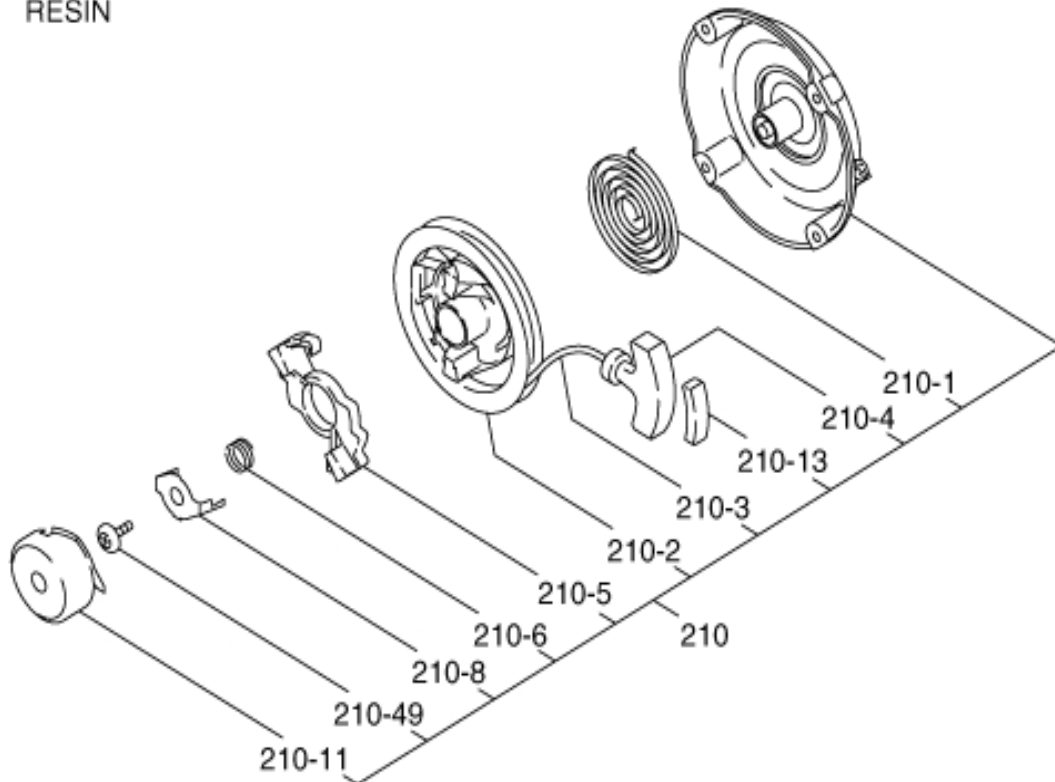

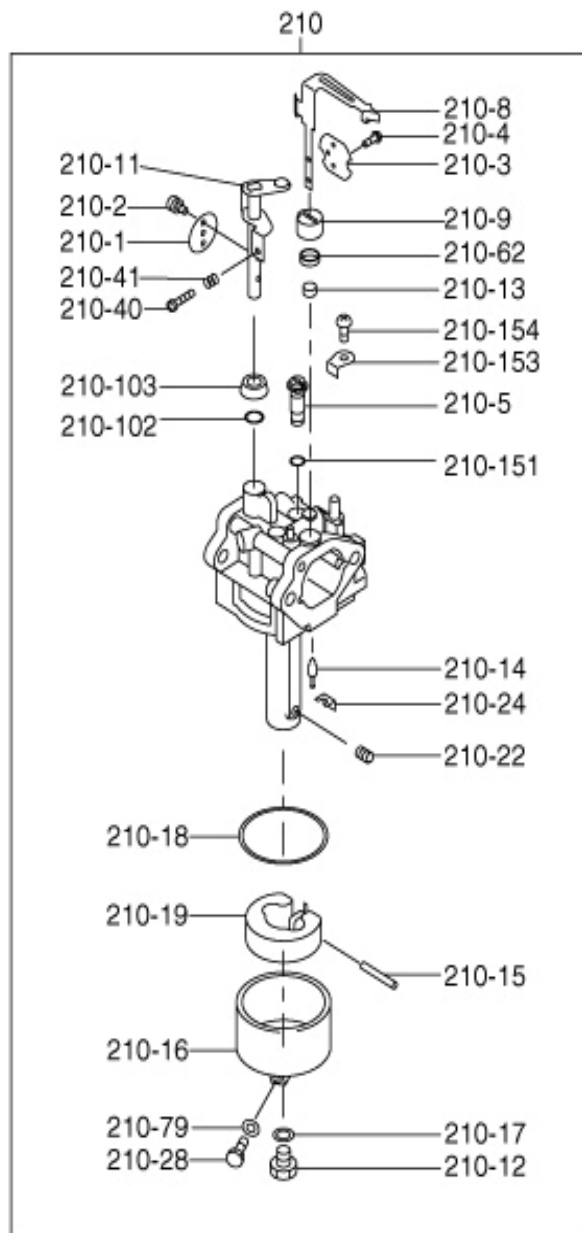

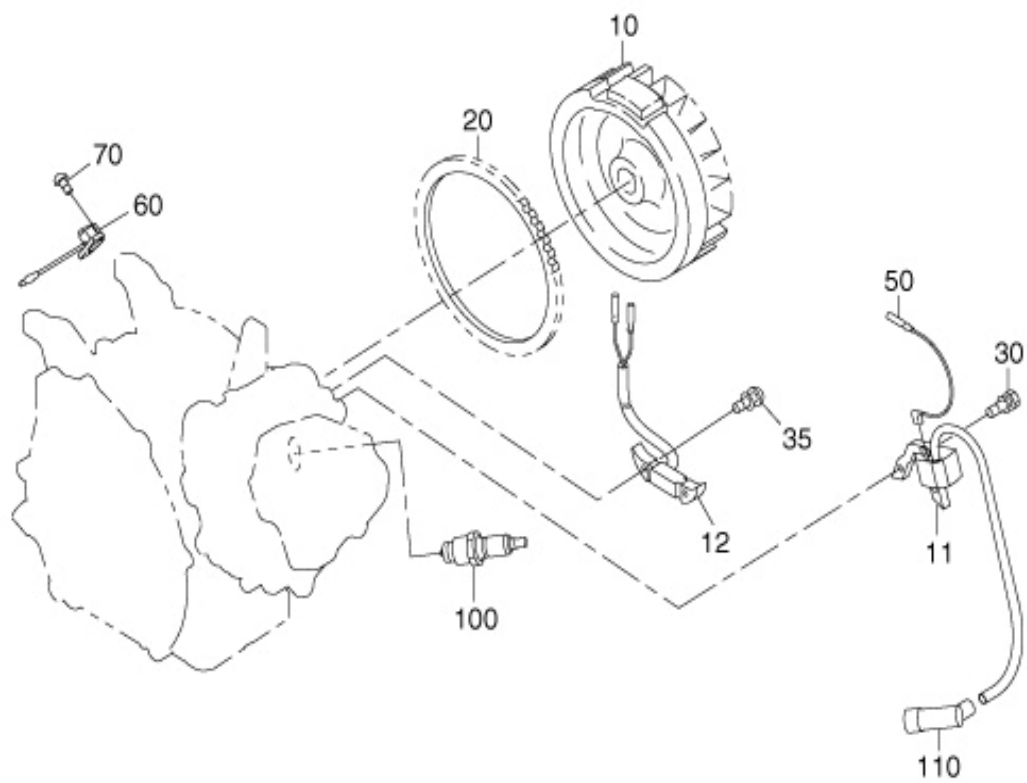

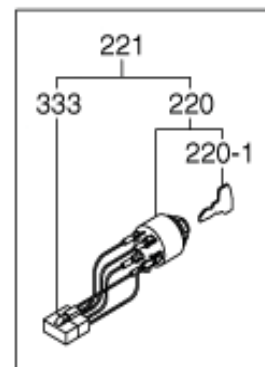
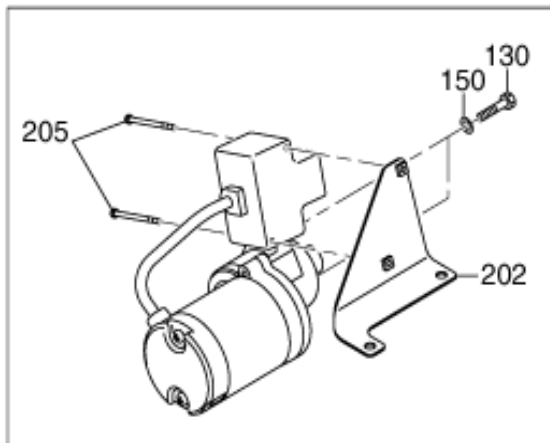
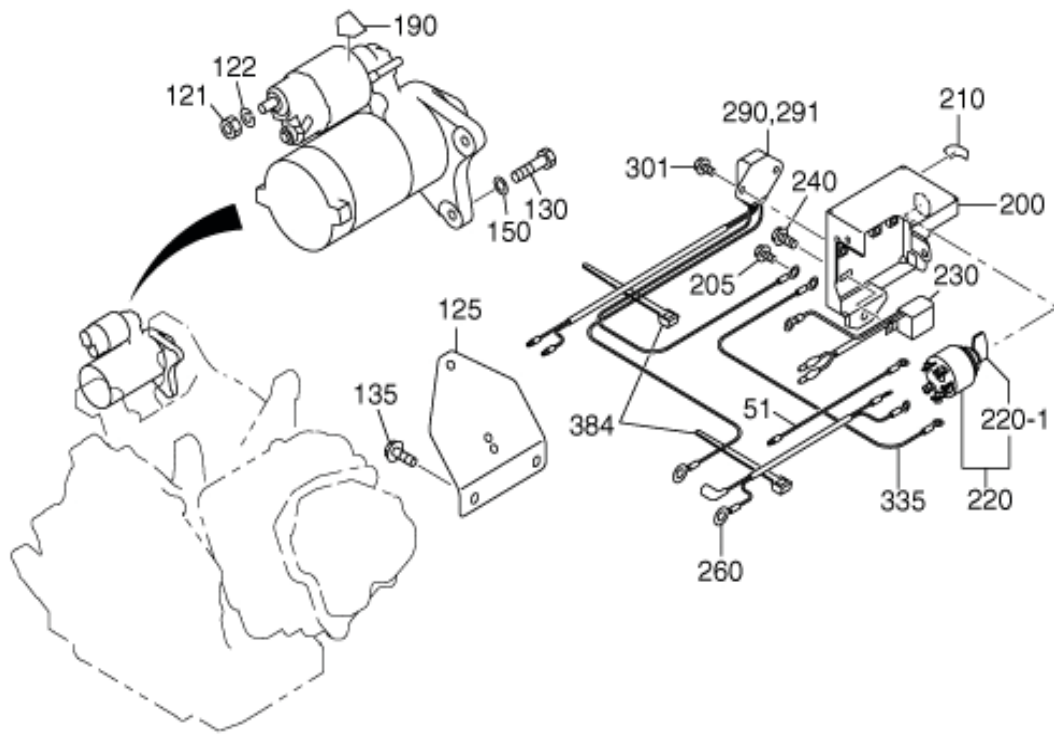

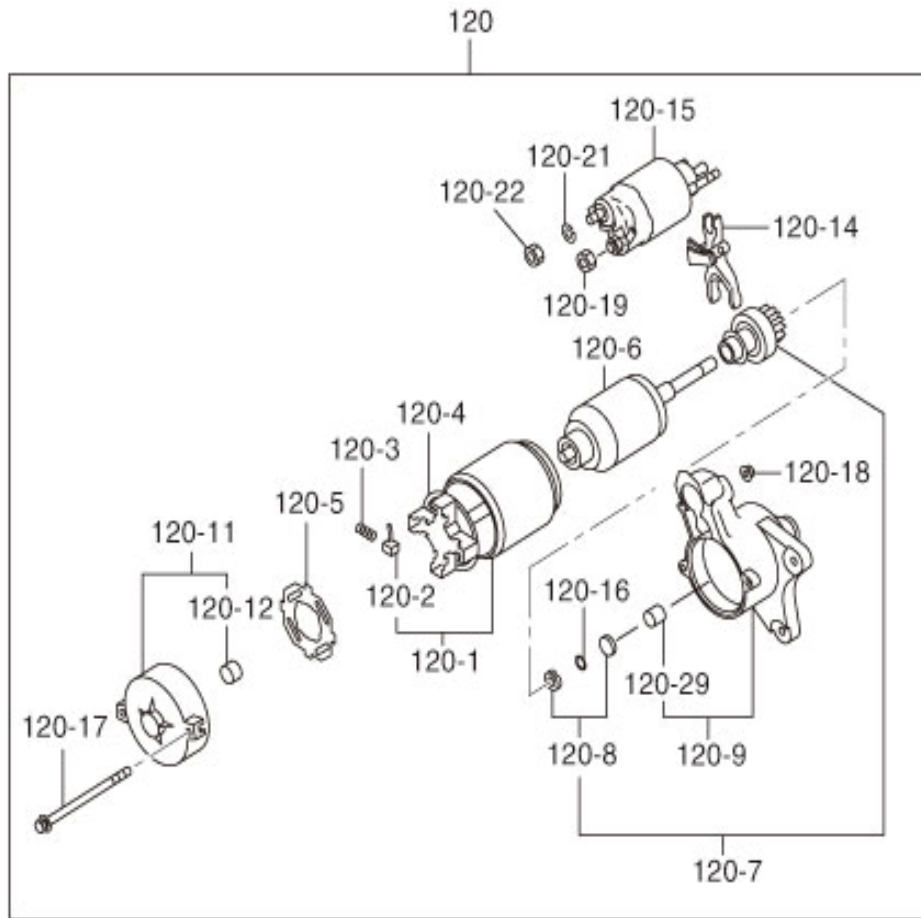

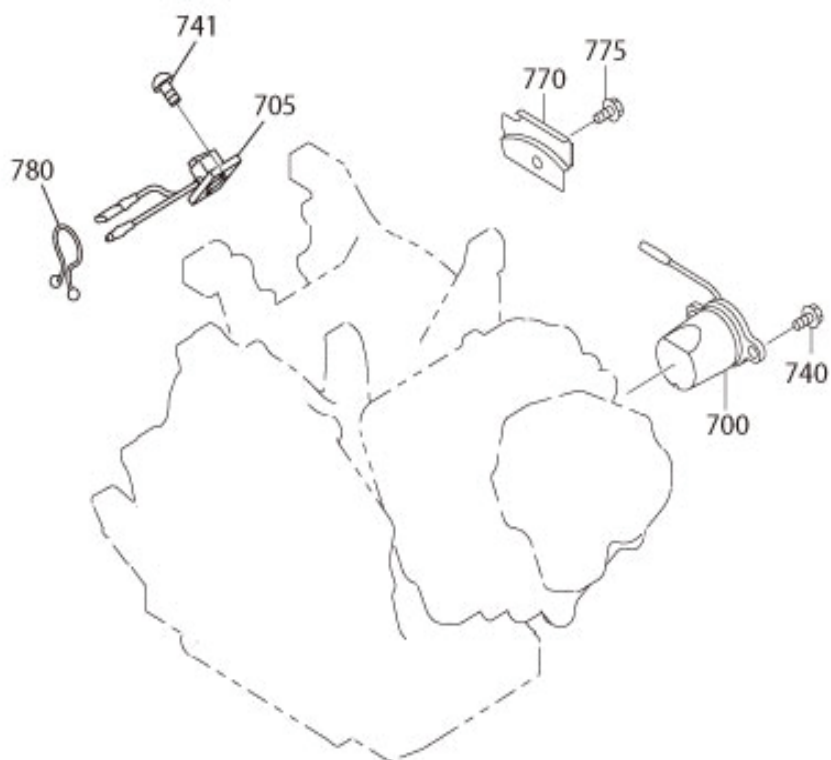

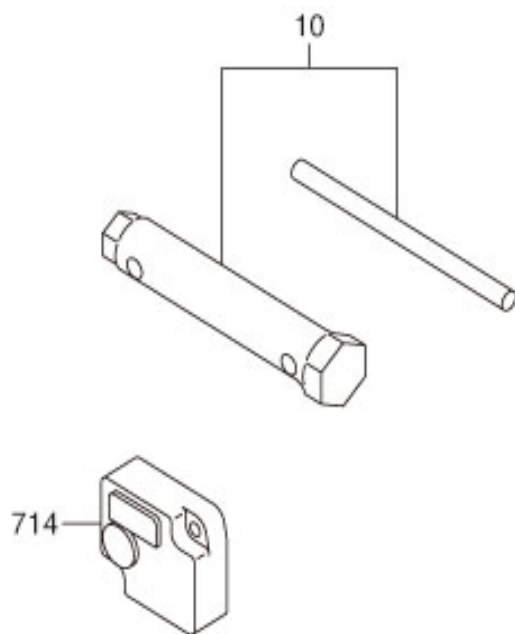

www.wormsentreprises.com



Siège social / Head Office

ZAC de Lamirault
39 rue de Lamirault, 77090 Collégien, FRANCE
TEL. +33 (0) 1 64 76 29 50
FAX +33 (0) 1 64 76 29 99

Services commercial et Pièces de rechange

Sales and Spare Parts Departments
TEL. +33 (0) 1 64 76 29 60
FAX +33 (0) 1 64 76 29 99