



WORMS
E N T R E P R I S E S

PARTS CATALOG

Model
EX40

Engine Model
EX400DH0123

13-09-2021



GROUP INDEX

Group Name	Page
CRANKCASE GROUP	4
CRANKSHAFT GROUP	6
INTAKE and EXHAUST GROUP.....	8
GOVERNOR GROUP	12
COOLING and STARTING GROUP	14
FUEL, LUBRICATION GROUP	18
ELECTRIC DEVICE GROUP	22
ACCESSORY GROUP	26

INDEX OF DESCRIPTION SYMBOLS			
SYMBOL	DESCRIPTION	SYMBOL	DESCRIPTION
AY	ASSEMBLY	P=	PITCH (in mm)
CP	COMPLETE	P.T.O. (PTO)	POWER TAKE OFF
EX	EXPORT (from Japan)	REF.	REFERENCE
FIG.	FIGURE	R.H. (RH)	RIGHT HAND SIDE
FR.	FRONT	RR.	REAR
"	INCH	STD.	STANDARD
INCL.	INCLUDE	SW	SWITCH
~L	LITER	T=	THICKNESS (in mm)
L=	LENGTH (in. mm)	UN	UNIT
L.H. (LH)	LEFT-HAND SIDE	U.S.	UNDER SIZE
MECH	MECHANICAL	~V	VOLTAGE
NO (NON)	NONE	~W	WATT
OPT.	OPTIONAL	W/	WITH
O.S.	OVER SIZE	W/O	WITHOUT

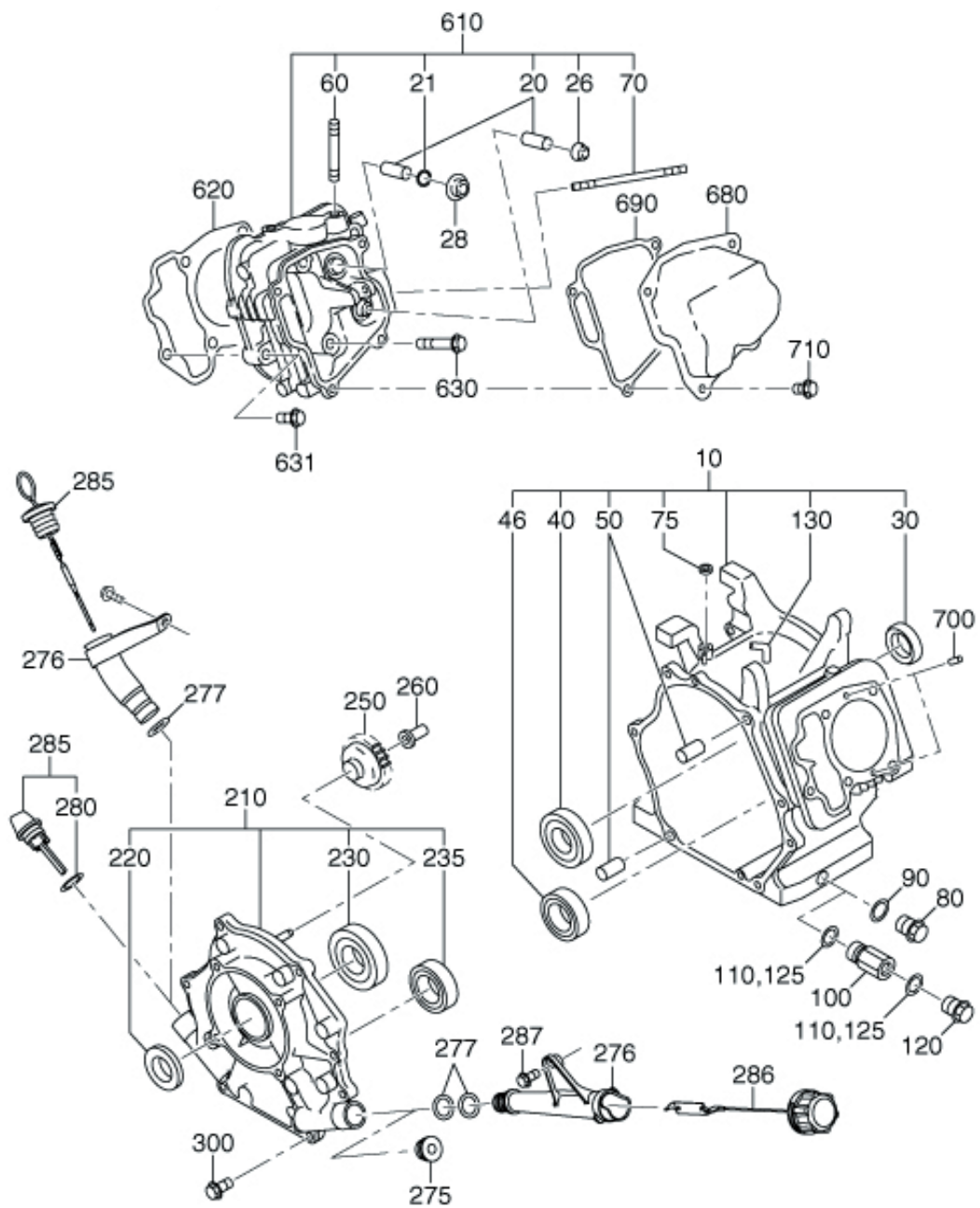

960- GASKET SET

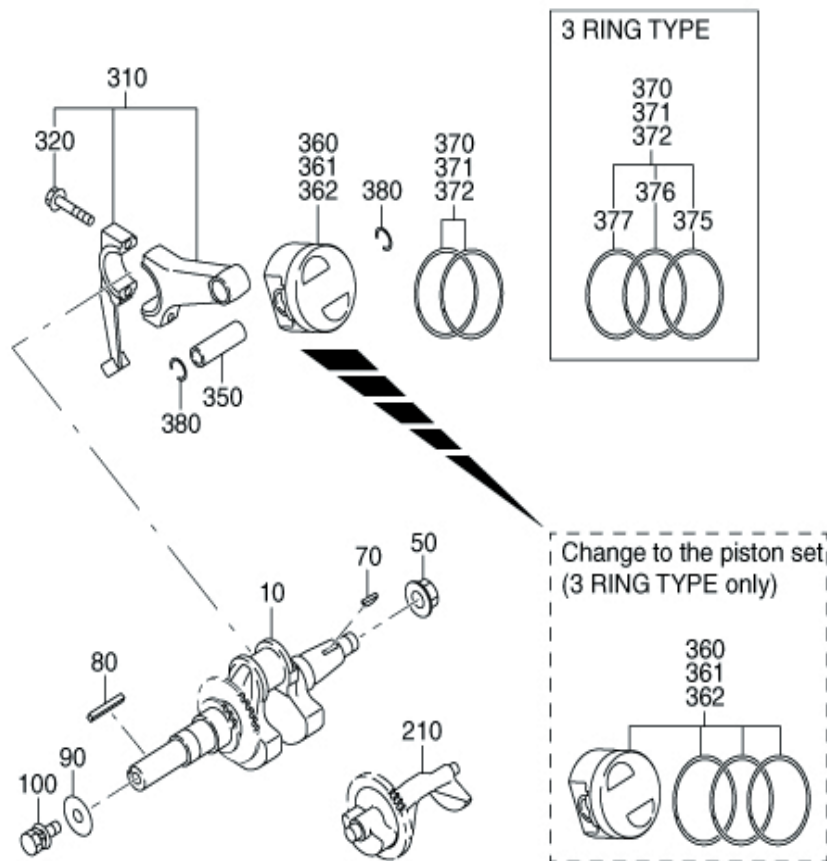

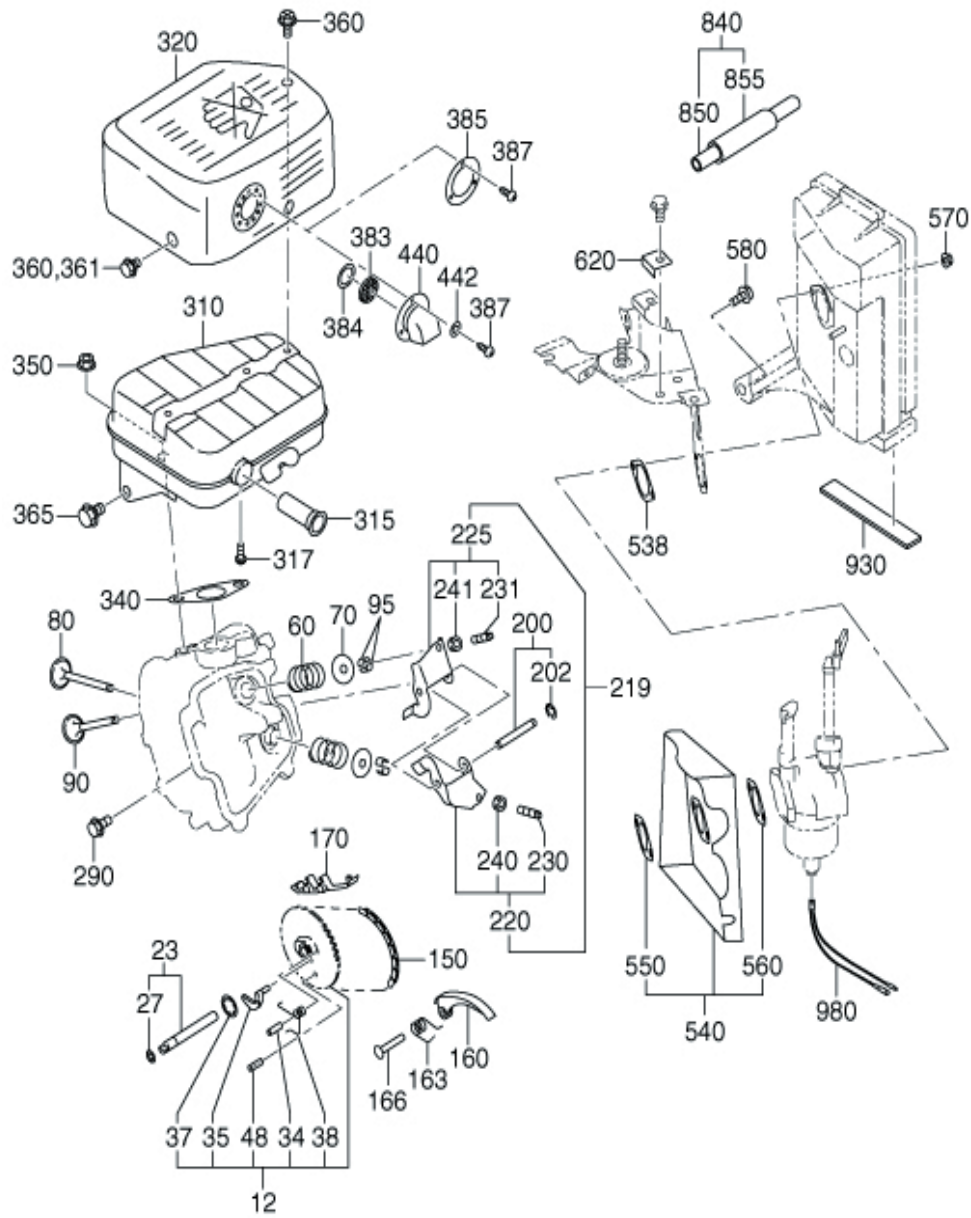
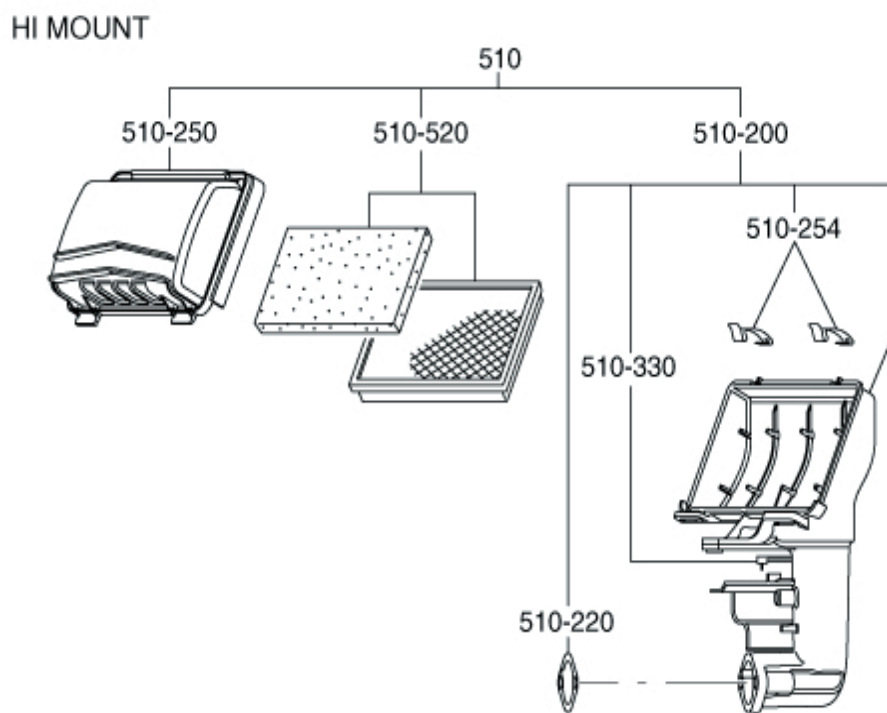
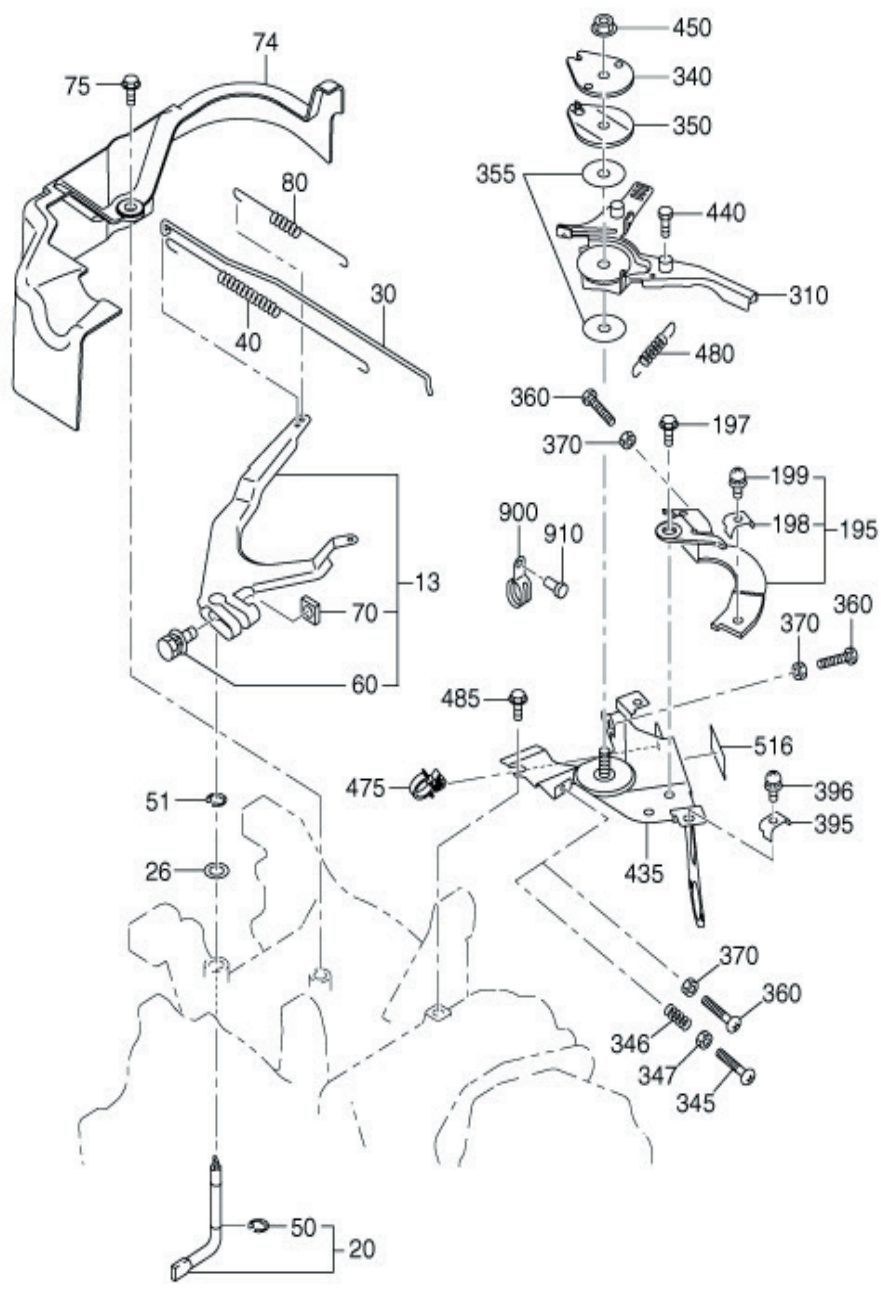

FIG. 300

INTAKE and EXHAUST GROUP

REF.	PART NUMBER	PART NAME	QTY.	REMARKS
12	22G3160100	CAMSHAFT AY	1	
23	22G3510101	PIN(CAM SHAFT)CP	1	
27	22G0280100	O-RING	1	
60	22G3361103	VALVE SPRING	2	22.2DX2.9DX37L N=6.5
70	22G3371103	SPRING RETAINER	2	
80	22G3340203	INTAKE VALVE	1	
90	22G3350203	EXHAUST VALVE	1	
95	22G3550103	COLLET-VALVE	4	
150	22G3560101	TIMING CHAIN CP	1	112LINK
160	20A3691103	TENTIONER	1	
163	20A3710103	SPRING(TENTIONER)	1	10DX1.8DX14L N=4.5
166	20A3690203	PIN(TENTIONER)	1	6DX13DX34L
170	20A3691303	CHAIN GUIDE	1	
200	22G3500101	PIN(ROCKER)CP	1	
202	22G0320300	CLIP	1	6DX12DX0.8T
220	22G3610100	ROCKER ARM(IN) AY	1	
225	22G3610200	ROCKER ARM(EX) AY	1	
290	20A0111100	FLANGE BOLT	1	M6X1.0X13DX12L
310	22G3010102	MUFFLER UN	1	
320	22G3420101	MUFFLER COVER CP	1	
340	22G3520103	GASKET(MUFFLER)	1	T=0.2
350	20A0185120	FLANGE NUT	2	M8X1.25X17DX7.5H
360	20A0111200	FLANGE BOLT	5	M6X1.0X14DX8L
365	22G0110400	FLANGE BOLT	1	M8X1.25X16DX16L
385	22G3710102	TAIL SCREEN UN	1	
387	22G0140200	TAPPING SCREW	3	
440	22G3700101	DEFLECTOR CP	1	
442	22G0210800	GASKET	3	
538	22G3590303	GASKET 3	1	T=0.8
540	22G3290101	INSULATOR CP	1	
550	22G3590203	GASKET 2	1	T=0.5
560	22G3590103	GASKET 1	1	T=0.5
570	20A0185200	FLANGE NUT	2	M6X1.0X13DX6H
580	20A0111500	FLANGE BOLT	1	M6X1.0X13DX16L
620	22G5710101	COVER STAY(A/C)	1	
850	22G0810400	RUBBER PIPE	1	10DX15DX170L





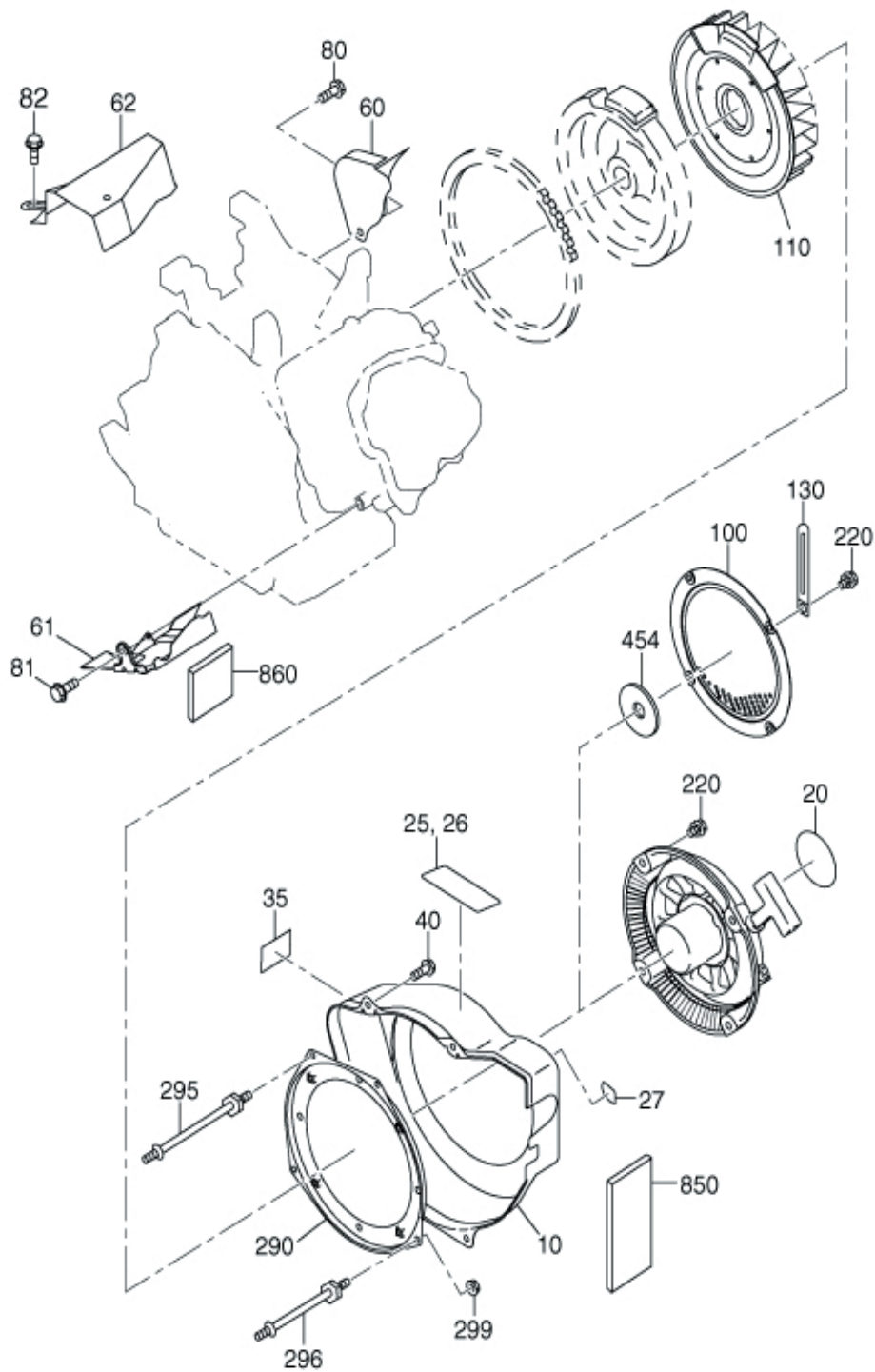

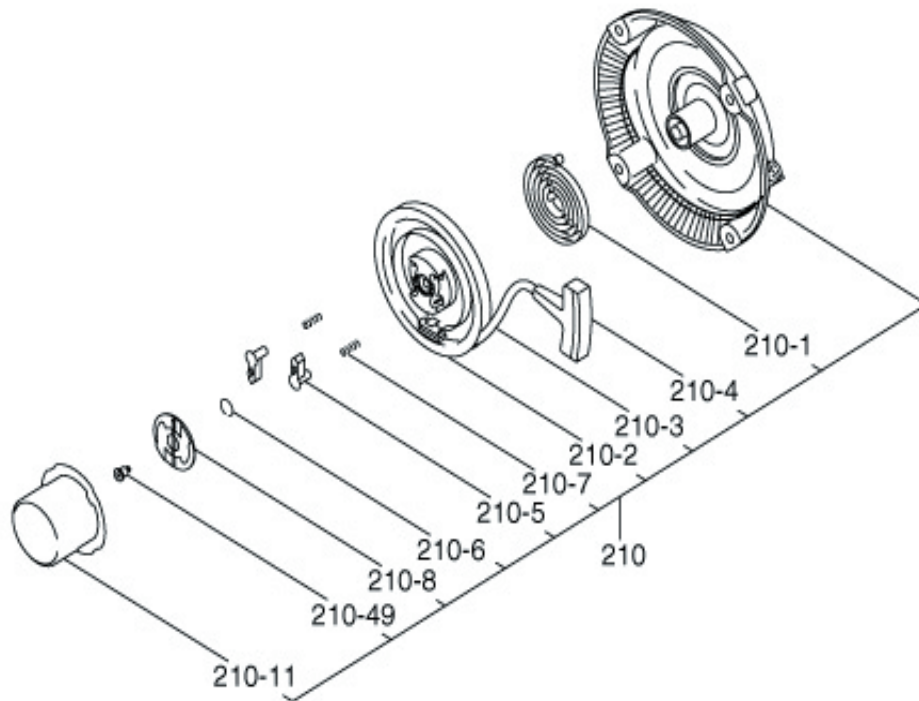

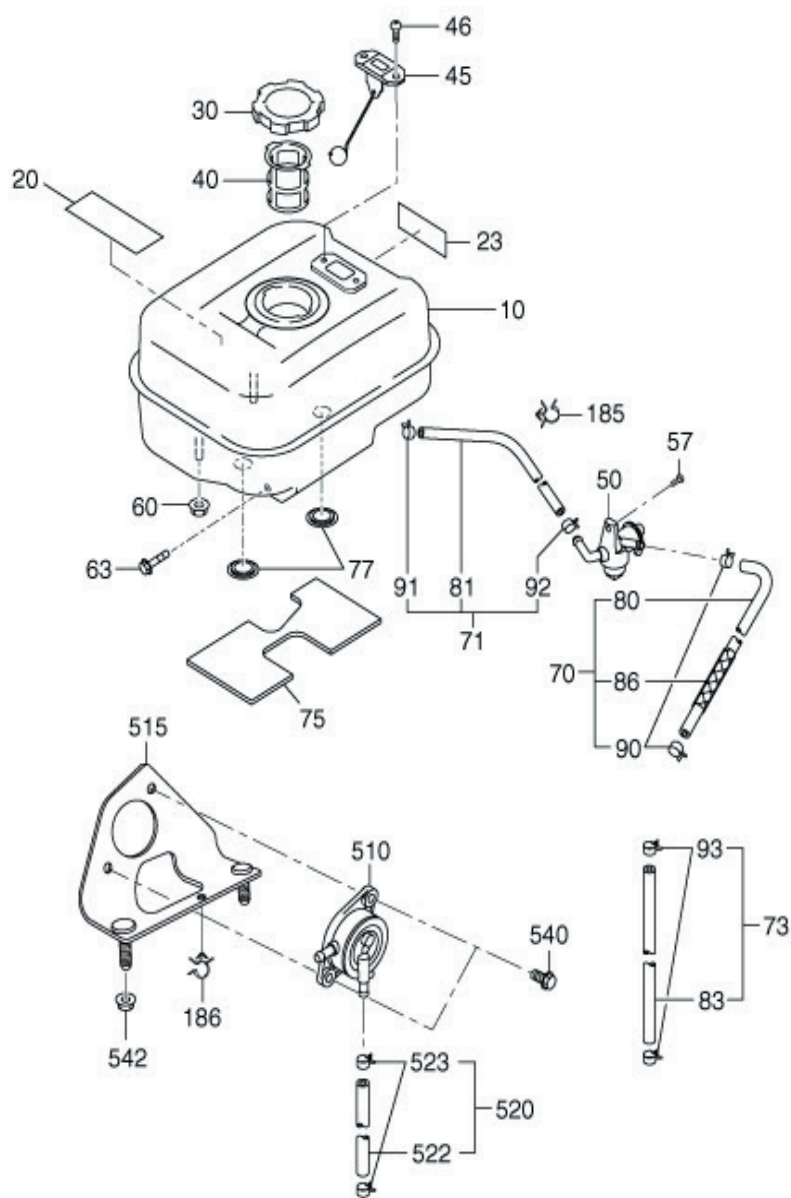

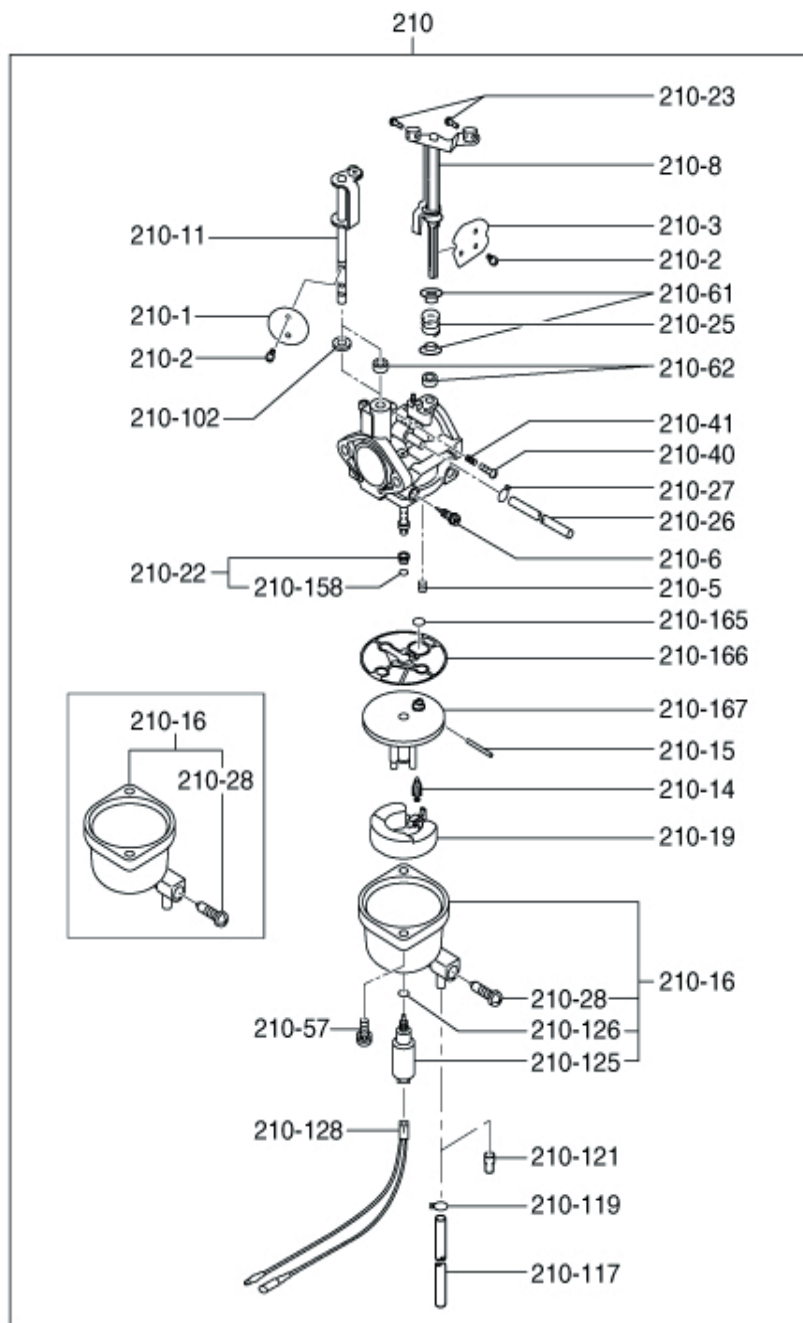

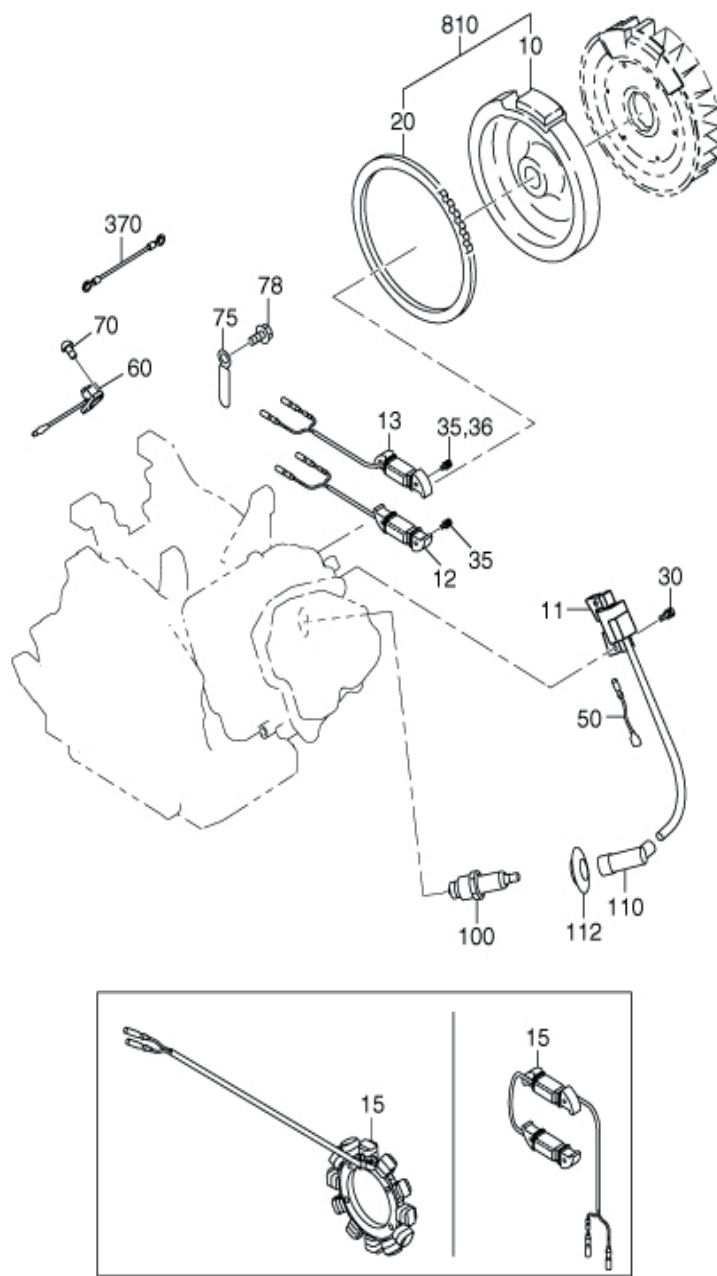

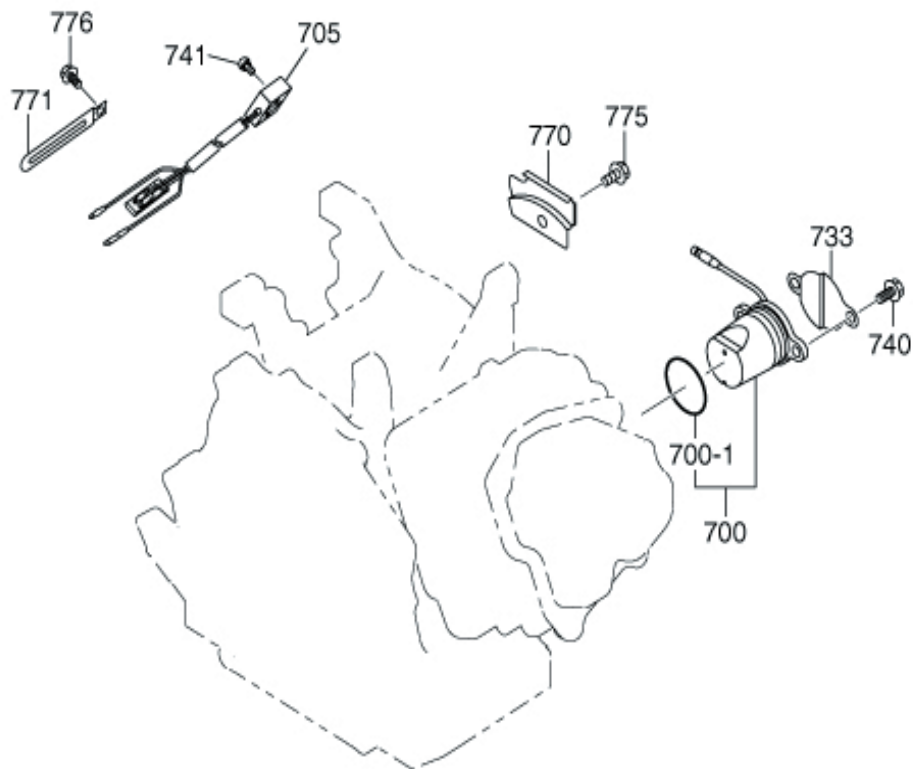

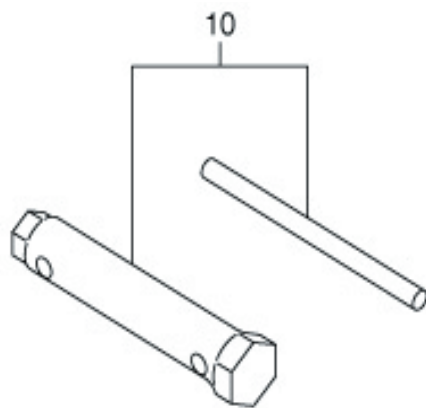

www.wormsentreprises.com



Siège social / Head Office

ZAC de Lamirault

39 rue de Lamirault, 77090 Collégien, FRANCE

TEL. +33 (0) 1 64 76 29 50

FAX +33 (0) 1 64 76 29 99

Services commercial et Pièces de rechange

Sales and Spare Parts Departments

TEL. +33 (0) 1 64 76 29 60

FAX +33 (0) 1 64 76 29 99