



mecc alte spa

MR1

MECCALTE spa - Via Roma, 20 - 36051 CREAZZO (VI) ITALIA
 Tel. 0444/396111 - Fax 0444/396166 - e-mail : mecc-alte-spa@meccalte.it
 web site: www.meccalte.com

2 POLE

1 PHASE

CARATTERISTICHE / CHARACTERISTICS / CARACTERISTIQUES / TECHNISCHE MERKMALE / CARACTERISTICAS

Tipo Type Type Typ Tipo	115/230V 50Hz 3000 RPM					120/240V 60Hz 3600 RPM					Peso Weight Poids Gewicht Peso	J	T.H.D.			
	kVA	η 4/4 1 p.f.	Volume d'aria Air volume Volume d'air Luftmenge Volumen de aire	Rumore Noise Bruit Gerausch Ruido		kVA	η 4/4 1 p.f.	Volume d'aria Air volume Volume d'air Luftmenge Volumen de aire	Rumore Noise Bruit Gerausch Ruido					Kg	Kgm ²	%
				7m dBA	1m dBA				7m dBA	1m dBA						
MR1 - 160/2	5	76	3,28	60	78	6	77	4,12	62	80	30,2	0,0154	< 6			
MR1 - 180/2	6	77	3,28	60	78	7,2	77,8	4,12	62	80	33,2	0,0171	< 6			

DIMENSIONI D'INGOMBRO / OVERALL DIMENSIONS / ENCOMBREMENT / BAUMASSE / DIMENSIONES MAXIMAS

dimensions in mm.

FORMA FORM FORME B14

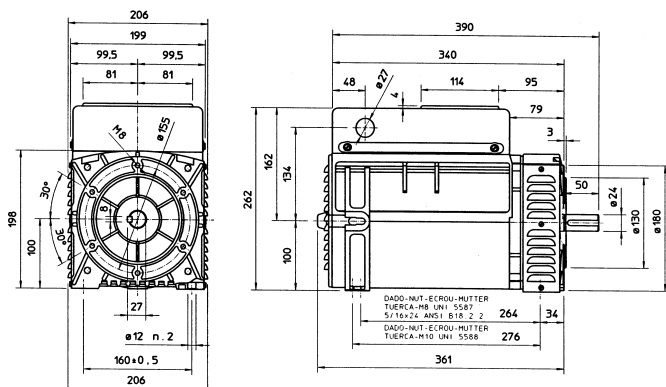

FORMA FORM FORME J609a

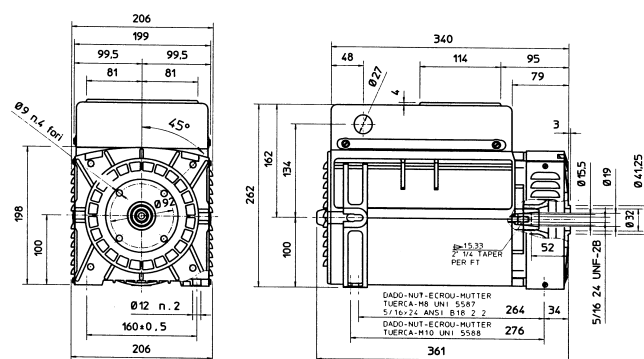

FORMA FORM FORME B9/c23

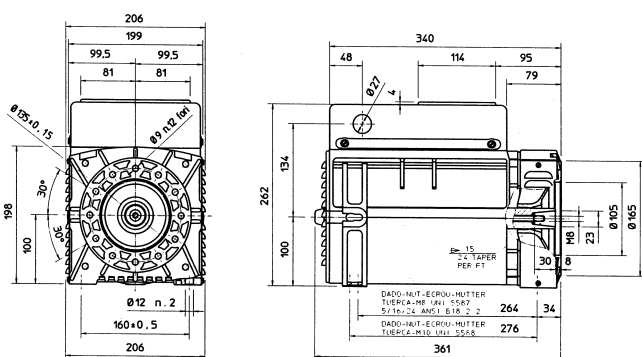

FORMA FORM FORME J609b

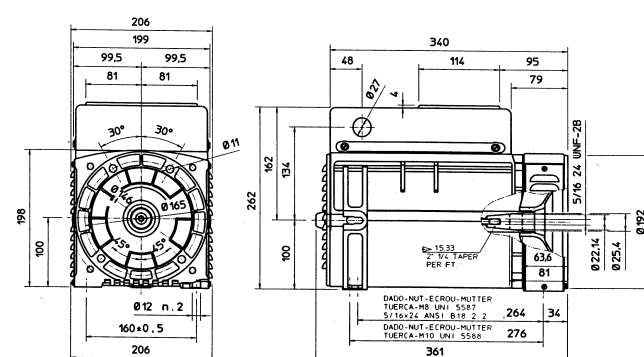

ELENCO PARTI DI RICAMBIO / LIST OF SPARE PARTS /LISTE DES PIÈCES DETACHEES
ERSATZTEILLISTE / LISTA PARTES DE REPUESTO

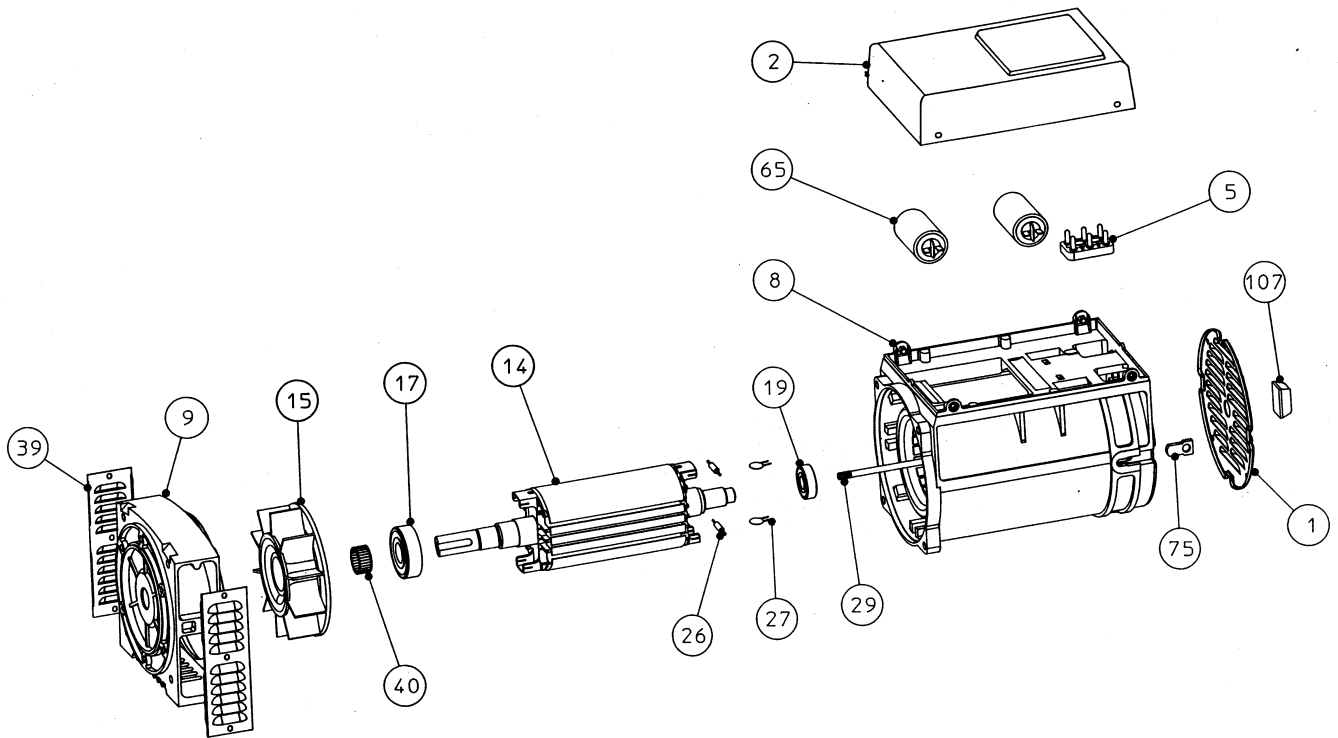

N.	DENOMINAZIONE	NAME	DESIGNATION	NAMEN	DENOMINACION	CODICE/CODE
1	griglia	grid	grille de fermeture	gitter	rejilla	0390700010
2	cuffia	terminal box lid	couvercle	deckel	tapa	0390501015
5	morsettiera utilizzaz.	terminal board	planchette à bornes	klemmenbrett	placa de bornes	0391100101
8	carcassa con statore	frame and stator	carcasse avec stator	gehäuse mit stator	carcaza con estator	***
9	coperchio forma B9	drive end bracket B9	flasque B9	flansch B9	brida B9	***
9	coperchio forma B14	drive end bracket B14	flasque B14	flansch B14	brida B14	0391700116
14	induttore rotante	rotor assy	roue polaire	rotierender induktor	inductor rotante	***
15	ventola	fan	ventilateur	lüfterrad	ventilador	0392000027
17	cuscinetto anter. 6205-2RS	drive end bearing 6205-2RS	roulement avant 6205-2RS	vorderes lager 6205-2RS	cojinete delantera 6205-2RS	0390302511
19	cuscinetto poster. 6203-2RS	non drive end bearing 6203-2RS	roulement arrière 6203-2RS	hinteres lager 6203-2RS	cojinete posterior 6203-2RS	0390302521
26	diodi	diode	diode	diode	diodo	0390400012
27	varistore	varistor	varistor	varistor	varistor	0392000256
29	tirante centrale	securing stud	tige central	zentriersstift	tirante central	***
39	retina protezione	protection screen	grille de protection	schützgitter	rejilla de protección	0390700009
40	anello compensatore	fixing ring	rondelle de bloquage	kompensator ring	anillo compensadores	0390100210
65	condensatore	capacitor	condensateur	kondensator	condensator	***
75	gommino	rubber cup	capouchon de fermeture en plastique	schlussgummi	goma de cierre	0390700306
107	tappo per cuffia poster.	securing stud cup	bouchon pour couvercle arrière	stöpsel für hinteres klemmkastendeckel	goma para tapa posterior	0391802006

N.B.- Nella richiesta di pezzi di ricambio specificare il tipo e il codice dell'alternatore.

When requesting spare parts always indicate the alternator's type and code.

Pour toute demande de pièces détachées, prière de mentionner le type et le code de l'alternateur.

Bei Ersatzteilbestellung bitte immer die Teilbenennung den Typ und den code des Wechselstromgenerators angeben.

En cada pedido de piezas de recambio especificar siempre el tipo y el código del alternador.