



SERVICE MANUAL

EH63
EH64
EH65
EH72

**EH63/EH64/EH65/EH72
SERVICE MANUAL
©2020 by Yamaha Motor Powered
Products Co., Ltd.
2nd Edition, October 2020
All rights reserved.
Any reprinting or unauthorized use
without the written permission of
Yamaha Motor Powered
Products Co., Ltd.
is expressly prohibited.**

IMPORTANT

This manual was produced by the Yamaha Motor Powered Products Co., Ltd. primarily for use by Yamaha dealers and their qualified mechanics. It is not possible to include all the knowledge of a mechanic in one manual. Therefore, anyone who uses this book to perform maintenance and repairs on Yamaha machines should have a basic understanding of mechanics and the techniques to repair these types of machines. Repair and maintenance work attempted by anyone without this knowledge is likely to render the machine unsafe and unfit for use.

Yamaha Motor Powered Products Co., Ltd. is continually striving to improve all of its models. Modifications and significant changes in specifications or procedures will be forwarded to all authorized Yamaha dealers and will appear in future editions of this manual where applicable.

TIP

Designs and specifications are subject to change without notice.

IMPORTANT MANUAL INFORMATION

Particularly important information is distinguished in this manual by the following notations.



This is the safety alert symbol. It is used to alert you to potential personal injury hazards. Obey all safety messages that follow this symbol to avoid possible injury or death.

WARNING

A WARNING indicates a hazardous situation which, if not avoided, could result in death or serious injury.

NOTICE

A NOTICE indicates special precautions that must be taken to avoid damage to the machine or other property.

TIP

A TIP provides key information to make procedures easier or clearer.

HOW TO USE THIS MANUAL

This manual is intended as a handy, easy-to-read reference book for the mechanic. Comprehensive explanations of all installation, removal, disassembly, assembly, repair and check procedures are laid out with the individual steps in sequential order.

- The manual is divided into chapters and each chapter is divided into sections. The current section title is shown at the top of each page “1”.
- Sub-section titles appear in smaller print than the section title “2”.
- To help identify parts and clarify procedure steps, there are exploded diagrams at the start of each removal and disassembly section “3”.
- Numbers are given in the order of the jobs in the exploded diagram. A number indicates a disassembly step “4”.
- Symbols indicate parts to be lubricated or replaced “5”. Refer to “SYMBOLS”.
- A job instruction chart accompanies the exploded diagram, providing the order of jobs, names of parts, notes in jobs, etc. “6”. This step explains removal procedure only. For installation, reverse the steps.
- Jobs requiring more information (such as special tools and technical data) are described sequentially “7”.

1

PISTONS, CAMSHAFT, CRANKCASE, AND CRANKSHAFT

PISTONS AND CRANKSHAFT

3

5

4

6

Order	Job/Parts to remove	Q'ty	Remarks
1	Removing the pistons and crankshaft	2	Remove the parts in the order listed.
2	Connecting rod cap	1	
3	Crankshaft shim	1	
4	Connecting rod	2	
5	Piston pin circlip	4	
6	Piston pin	2	
7	Piston	2	
8	Piston ring	2	Top ring
9	Piston ring	2	2nd ring
10	Piston ring	2	Oil ring

3-46

PISTONS, CAMSHAFT, CRANKCASE, AND CRANKSHAFT

INSTALLING THE CRANKCASE COVER

7

Install:

- Crankcase cover
- Crankcase cover bolts “1”-“10”

Crankcase cover bolt:
25 N·m (2.5 kgf·m, 18 lb·ft)

2

CHECKING THE CYLINDERS AND PISTONS

1. Check:

- Piston wall
- Cylinder wall

Vertical scratches → Replace the cylinder, and replace the piston and piston rings as a set.

2. Measure:

- Cylinder warpage

TIP
Measure the warpage on the contact surface of the cylinder head at six points using a straight edge and thickness gauge.

Thickness gauge:
90890-03268
Feeler gauge set:
YU-26900-9

Warpage limit:
0.1 mm (0.0039 in)

Out of specification → Replace the crankcase assembly.

3. Measure:

- Piston-to-cylinder clearance

a. Measure the cylinder bore “C” with the cylinder bore gauge.











3-54

SYMBOLS

The following symbols are used in this manual for easier understanding.

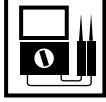
TIP

The following symbols are not relevant to every machine.

SYMBOL	DEFINITION	SYMBOL	DEFINITION
	Filling fluid		Lubricant
	Special tool		Tightening torque
	Wear limit, clearance		Engine speed
	Electrical data	New	Replace the part with a new one.
	Lithium-soap base grease		Molybdenum disulfide grease
	Engine oil		Apply locking agent (LOCTITE®)

INDEX

GENERAL INFORMATION

1

**PERIODIC CHECKS AND
ADJUSTMENTS**

2

3

ENGINE

4

5

6

FUEL

7

ELECTRICAL

TROUBLESHOOTING

SPECIFICATIONS

TABLE OF CONTENTS

GENERAL INFORMATION

MACHINE IDENTIFICATION	1-1
SERIAL NUMBER	1-1
DIMENSIONS	1-2
DIMENSION CHART FOR P.T.O.	1-2
TOP	1-4
MOUNTING BASE	1-4
LEFT SIDE	1-5
FRONT	1-5
REAR	1-6
IMPORTANT INFORMATION	1-7
PREPARATION FOR REMOVAL AND DISASSEMBLY	1-7
CAUTION ON SERVICE	1-7
NOTES ON SERVICE	1-7
ALL REPLACEMENT PARTS.....	1-8
GASKETS, OIL SEALS, AND O-RINGS	1-8
BEARINGS AND OIL SEALS.....	1-9
BASIC SERVICE INFORMATION	1-9
ELECTRICAL SYSTEM	1-9
SPECIAL TOOLS AND TESTERS	1-13

PERIODIC CHECKS AND ADJUSTMENTS

INTRODUCTION	2-1
MAINTENANCE INTERVALS CHART	2-1
PERIODIC MAINTENANCE/ LUBRICATION INTERVALS	2-1
PERIODIC MAINTENANCE	2-3
SPARK PLUGS	2-3
FUEL LEAKAGE	2-4
FUEL FILTER	2-4
ENGINE OIL LEAKAGE	2-5
ENGINE OIL LEVEL.....	2-5
REPLACING THE ENGINE OIL.....	2-6
OIL COOLER (EH72A/EH72B/ EH72K).....	2-8
AIR FILTER ELEMENT	2-8
MUFFLER	2-11
BREATHING HOSE	2-12

CYLINDER HEAD DECARBONIZATION.....	2-12
ADJUSTING THE VALVE CLEARANCE	2-13
ENGINE SPEED (EH63K/EH64A/ EH64K/EH65A/EH65B)	2-15
ENGINE SPEED (EH72A/EH72B/ EH72K)	2-17
FITTINGS AND FASTENERS.....	2-19

ENGINE

ENGINE INSPECTION	3-1
MEASURING THE COMPRESSION PRESSURE	3-1
AIR FILTER	3-3
EH63K/EH64A/EH64K/EH65A/ EH65B	3-3
EH72A/EH72B/EH72K.....	3-4
MUFFLER	3-5
EH63K/EH72B/EH72K.....	3-5
EH64K	3-6
EH65B	3-7
EH65A/EH72A	3-8
INSTALLING THE MUFFLER	3-9
OIL COOLER AND OIL FILTER	3-10
REMOVING THE OIL COOLER (EH72A/EH72B/EH72K)	3-11
CHECKING THE OIL COOLER (EH72A/EH72B/EH72K)	3-11
INSTALLING THE OIL COOLER (EH72A/EH72B/EH72K)	3-11
RECTIFIER/REGULATOR	3-13
CASE AND FAN	3-14
REMOVING THE CASE AND FAN	3-15
CHECKING THE CASE AND FAN	3-15
INSTALLING THE CASE AND FAN.....	3-16
CYLINDER COVERS	3-17
CYLINDER COVER 1 AND CYLINDER COVER 2	3-17
CYLINDER COVER 3	3-18
TCI UNITS, FLYWHEEL AND STATOR COIL ASSEMBLY	3-19
TCI UNITS	3-19

FLYWHEEL AND STATOR COIL ASSEMBLY	3-20
REMOVING THE FLYWHEEL AND STATOR COIL ASSEMBLY.....	3-21
CHECKING THE FLYWHEEL AND STATOR COIL ASSEMBLY.....	3-22
INSTALLING THE FLYWHEEL AND STATOR COIL ASSEMBLY.....	3-22
INSTALLING THE TCI UNITS	3-23

ENGINE SWITCH AND OIL WARNING LIGHT (EQUIPPED MODELS ONLY) 3-25

CYLINDER HEAD COVERS, CYLINDER HEADS 3-26

CYLINDER HEAD #1	3-26
CYLINDER HEAD #2	3-29
CHECKING THE ROCKER ARMS	3-32
REMOVING THE CYLINDER HEADS	3-32
CHECKING THE CYLINDER HEADS	3-32
INSTALLING THE CYLINDER HEAD ASSEMBLIES.....	3-33

VALVES 3-34

CYLINDER HEAD #1	3-34
CYLINDER HEAD #2	3-35
REMOVING THE VALVES AND VALVE SPRINGS	3-36
CHECKING THE VALVES AND VALVE SPRINGS	3-36
CHECKING THE VALVE SEATS	3-38
VALVE LAPPING	3-39
INSTALLING THE VALVES AND VALVE SPRINGS	3-40

OIL PUMP..... 3-41

DISASSEMBLING THE OIL PUMP.....	3-42
CHECKING THE OIL PUMP	3-42
ASSEMBLING THE OIL PUMP.....	3-42

PISTONS, CAMSHAFT, CRANKCASE, AND CRANKSHAFT 3-44

CRANKCASE COVER	3-44
CAMSHAFT.....	3-45
PISTONS AND CRANKSHAFT	3-46
CRANKCASE.....	3-47
CHECKING THE RELIEF VALVE.....	3-48
ASSEMBLING THE RELIEF VALVE ...	3-48

CHECKING THE OIL PUMP STRAINER.....	3-48
ASSEMBLING THE OIL PUMP STRAINER.....	3-48
REMOVING THE FLYWEIGHT SHAFT ASSEMBLY AND GOVERNOR FORK	3-48
DISASSEMBLING THE FLYWEIGHT SHAFT ASSEMBLY	3-49
CHECKING THE FLYWEIGHT SHAFT ASSEMBLY	3-49
ASSEMBLING THE FLYWEIGHT SHAFT ASSEMBLY	3-50
INSTALLING THE FLYWEIGHT SHAFT ASSEMBLY AND GOVERNOR FORK	3-50
REMOVING THE CAMSHAFT AND VALVE LIFTERS	3-51
CHECKING THE CAMSHAFT	3-51
CHECKING THE VALVE LIFTERS.....	3-53
INSTALLING THE VALVE LIFTERS AND CAMSHAFT	3-53
CHECKING THE CRANKCASE COVER	3-53
INSTALLING THE CRANKCASE COVER	3-54
CHECKING THE CYLINDERS AND PISTONS	3-54
CHECKING THE CRANKCASE	3-56
CHECKING THE PISTON PINS	3-56
CHECKING THE PISTON RINGS	3-57
CHECKING THE CRANKSHAFT	3-58
CHECKING THE CONNECTING RODS OIL CLEARANCE.....	3-58
INSTALLING THE PISTONS AND PISTON RINGS	3-59
INSTALLING THE CRANKSHAFT.....	3-60
SELECTING THE CRANKSHAFT SHIM.....	3-62

FUEL

FUEL PUMP.....	4-1
EH63K/EH64A/EH64K/EH65A/	
EH65B	4-1
EH72A/EH72B/EH72K.....	4-2
CHECKING THE FUEL PUMP	4-3

CARBURETOR ASSEMBLY	4-4
REMOVING THE CARBURETOR (EH63K/EH64A/EH64K/EH65A/ EH65B).....	4-4
DISASSEMBLING THE CARBURETOR (EH64A/EH65B)	4-5
DISASSEMBLING THE CARBURETOR (EH63K/EH64K/ EH65A).....	4-7
REMOVING THE CARBURETOR (EH72A/EH72B/EH72K).....	4-9
DISASSEMBLING THE CARBURETOR (EH72A/EH72B/ EH72K).....	4-10
REMOVING THE CARBURETOR ASSEMBLY	4-11
CHECKING THE CARBURETOR	4-11
INSTALLING THE CARBURETOR ASSEMBLY	4-12
ADJUSTING THE GOVERNOR.....	4-13
INTAKE MANIFOLD.....	4-14
EH63K/EH64A/EH64K/EH65A/ EH65B	4-14
EH72A/EH72B/EH72K	4-15
REMOVING THE INTAKE MANIFOLD.....	4-16
CHECKING THE INTAKE MANIFOLD.....	4-16
INSTALLING THE INTAKE MANIFOLD.....	4-16

ELECTRICAL

CIRCUIT DIAGRAM	5-1
ELECTRICAL COMPONENTS	5-3
CHECKING THE SWITCH CONTINUITY	5-5
CHECKING THE OIL PRESSURE SWITCH	5-5
CHECKING THE IGNITION SPARK GAP	5-6
CHECKING THE AIR GAP.....	5-7
CHECKING THE IGNITION COIL (TCI UNIT, PRIMARY) RESISTANCE	5-7
CHECKING THE IGNITION COIL (TCI UNIT, SECONDARY) RESISTANCE	5-7

CHECKING THE ENGINE SWITCH (EQUIPPED MODELS ONLY)	5-8
CHECKING THE STARTER MOTOR OPERATION	5-8
CHECKING THE WIRE HARNESS.....	5-9

ELECTRIC STARTING SYSTEM.....	5-10
REMOVING THE STARTER MOTOR.....	5-10

CHARGING SYSTEM	5-11
CHECKING THE STATOR COIL ASSEMBLY	5-11
CHECKING THE RECTIFIER/ REGULATOR	5-11

TROUBLESHOOTING

ENGINE DOES NOT START	6-1
ELECTRIC STARTING SYSTEM.....	6-2
ENGINE STARTS BUT STALLS.....	6-2
ENGINE SPEED DOES NOT INCREASE.....	6-3
ENGINE SPEED IS UNEVEN	6-4
THE BATTERY (OPTION) IS NOT CHARGED	6-4
GOVERNOR OPERATION.....	6-5

SPECIFICATIONS

GENERAL SPECIFICATIONS	7-1
MAINTENANCE SPECIFICATIONS.....	7-3
ENGINE	7-3
ELECTRICAL.....	7-7
TIGHTENING TORQUES.....	7-8
GENERAL TORQUE SPECIFICATIONS.....	7-10
LUBRICATION POINTS AND TYPE OF LUBRICANTS	7-11
WIRE ROUTING DIAGRAM	7-12
FUEL PUMP AND FUEL HOSE (EH63K)	7-12

FUEL PUMP AND FUEL HOSE (EH64A).....	7-13	RECTIFIER/REGULATOR AND STARTER MOTOR (EH63K).....	7-36
FUEL PUMP AND FUEL HOSE (EH64K, EXCEPT FOR KOR).....	7-14	RECTIFIER/REGULATOR AND STARTER MOTOR (EH64A).....	7-37
FUEL PUMP AND FUEL HOSE (EH64K, FOR KOR).....	7-15	RECTIFIER/REGULATOR AND STARTER MOTOR (EH64K, EXCEPT FOR KOR).....	7-38
FUEL PUMP AND FUEL HOSE (EH65A).....	7-16	RECTIFIER/REGULATOR AND STARTER MOTOR (EH64K, FOR KOR).....	7-39
FUEL PUMP AND FUEL HOSE (EH65B).....	7-17	RECTIFIER/REGULATOR AND STARTER MOTOR (EH65A).....	7-40
FUEL PUMP AND FUEL HOSE (EH72A).....	7-18	RECTIFIER/REGULATOR AND STARTER MOTOR (EH65B).....	7-41
FUEL PUMP AND FUEL HOSE (EH72B, FOR SEA/EH72K, FOR CHN).....	7-19	RECTIFIER/REGULATOR AND STARTER MOTOR (EH72A).....	7-42
FUEL PUMP AND FUEL HOSE (EH72K, EXCEPT FOR CHN).....	7-20	RECTIFIER/REGULATOR AND STARTER MOTOR (EH72B, FOR SEA/EH72K, FOR CHN).....	7-43
AIR FILTER, CARBURETOR AND FUEL HOSE (EH63K/EH64A/EH64K, EXCEPT FOR KOR).....	7-21	RECTIFIER/REGULATOR AND STARTER MOTOR (EH72K, EXCEPT FOR CHN).....	7-44
AIR FILTER, CARBURETOR AND FUEL HOSE (EH64K, FOR KOR/ EH65A/EH65B).....	7-22		
AIR FILTER, CARBURETOR AND FUEL HOSE (EH72A/EH72B/ EH72K).....	7-23		
CARBURETOR AND INTAKE MANIFOLD (EH64A/EH64K, EXCEPT FOR KOR).....	7-24		
CARBURETOR AND INTAKE MANIFOLD (EH64K, FOR KOR/ EH65A/EH65B).....	7-25		
CARBURETOR AND INTAKE MANIFOLD (EH72A/EH72B/ EH72K).....	7-26		
TCI UNIT (EH63K).....	7-27		
TCI UNIT (EH64A).....	7-28		
TCI UNIT (EH64K, EXCEPT FOR KOR).....	7-29		
TCI UNIT (EH64K, FOR KOR).....	7-30		
TCI UNIT (EH65A).....	7-31		
TCI UNIT (EH65B).....	7-32		
TCI UNIT (EH72A).....	7-33		
TCI UNIT (EH72B, FOR SEA/EH72K, FOR CHN).....	7-34		
TCI UNIT (EH72K, EXCEPT FOR CHN).....	7-35		

MEMO

GENERAL INFORMATION

MACHINE IDENTIFICATION

SERIAL NUMBER

The serial number is printed on the label affixed to the position “1” of the multi-purpose engine as shown in the illustration.

TIP

- The first four digits identify the model, and the remaining digits indicate the production number.
- Designs and specifications are subject to change without notice.

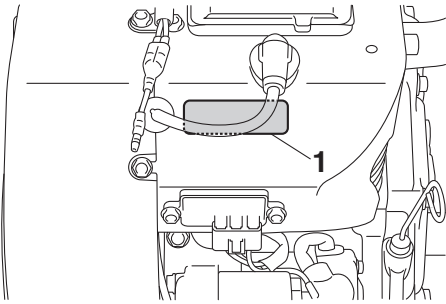

DIMENSIONS

DIMENSIONS

DIMENSION CHART FOR P.T.O.

mm (in)

1
GENERAL INFORMATION

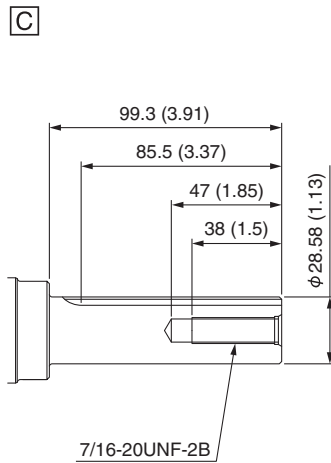
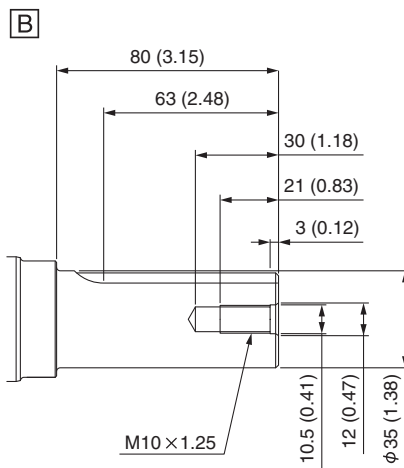
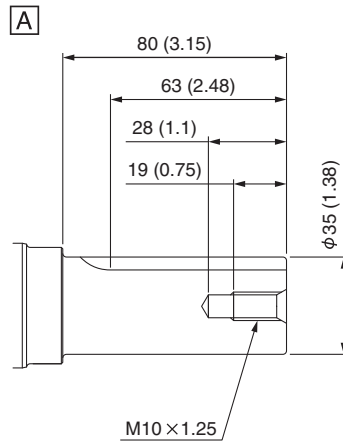

DIMENSIONS

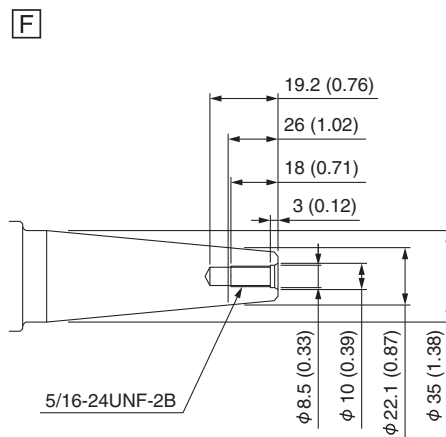
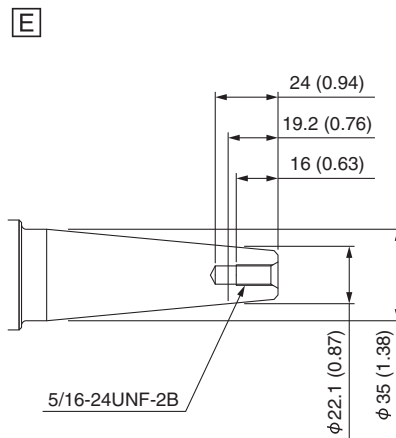
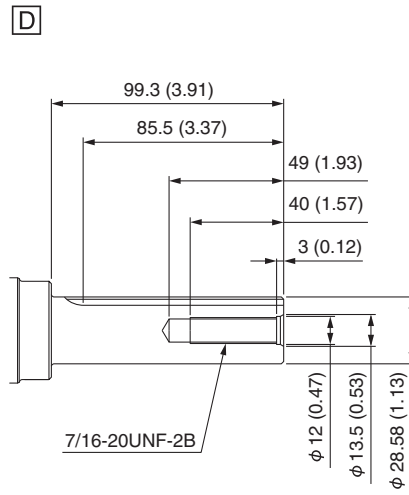

UNF: Unified fine thread (Unit: in)

A: EH65B, EH72B

B: EH65B, EH72B

C: EH64A, EH65A, EH72A

D: EH64A, EH65A, EH72A

E: EH63K, EH64K, EH72K

F: EH63K, EH64K, EH72K

DIMENSIONS

TOP

1
GENERAL INFORMATION

mm (in)

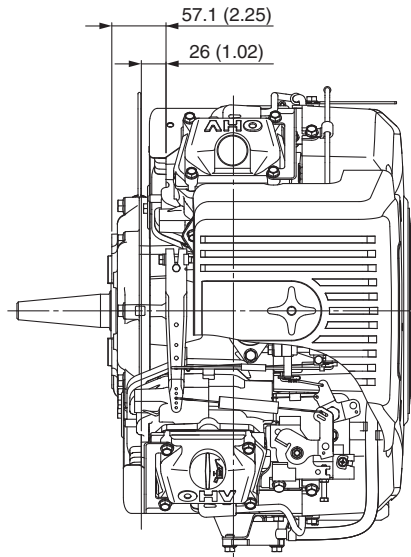

MOUNTING BASE

mm (in)

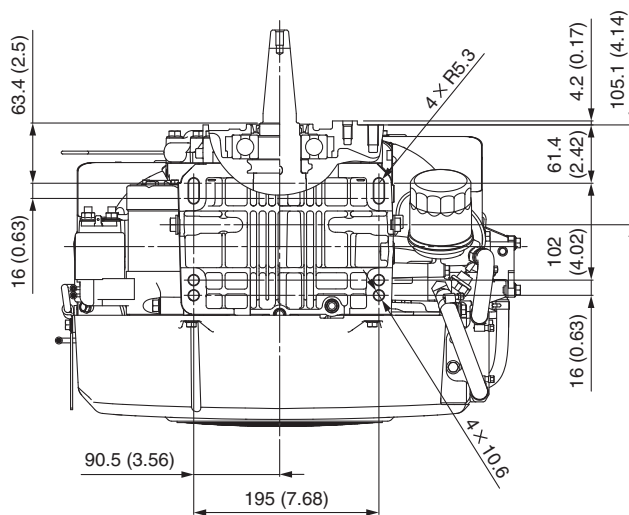

DIMENSIONS

LEFT SIDE

mm (in)

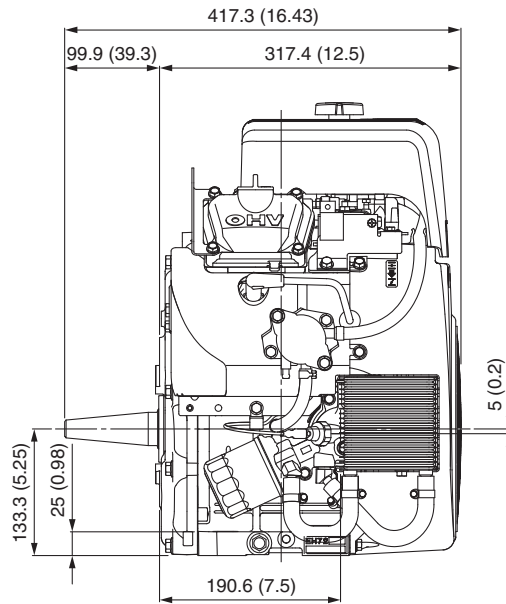

FRONT

mm (in)

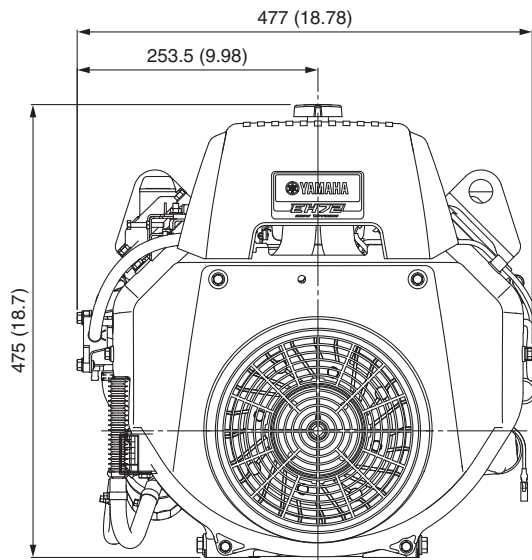

DIMENSIONS

REAR

mm (in)

1

GENERAL INFORMATION

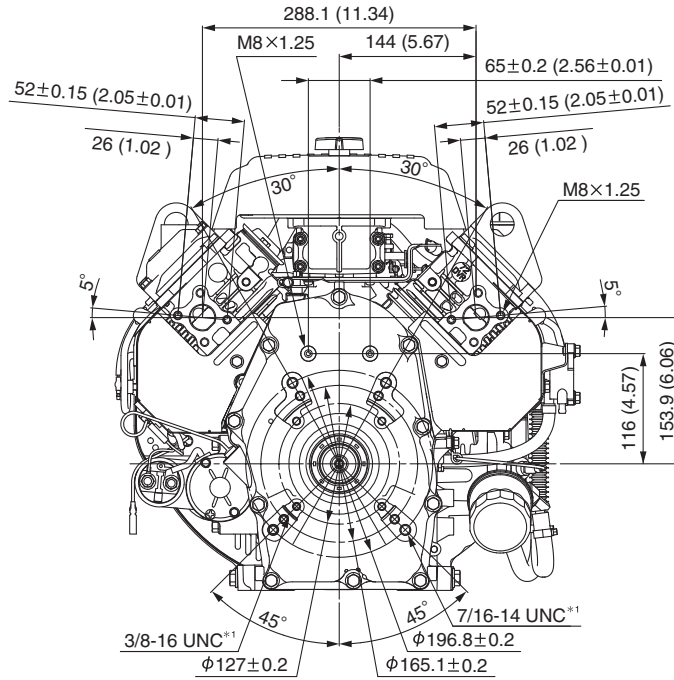

*1: UNC: Unified coarse thread (Unit: in)

IMPORTANT INFORMATION

PREPARATION FOR REMOVAL AND DISASSEMBLY

CAUTION ON SERVICE

Fire prevention

When servicing the engine, always keep the engine and yourself away from fire.

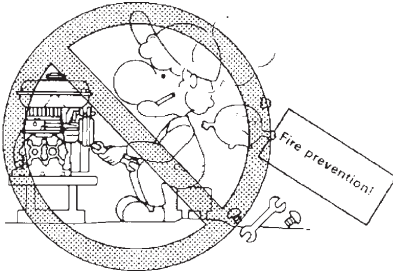

NOTES ON SERVICE

Correct tools

Be sure to use the correct special tool for the job to guard against damage.



Oil, grease and seals

Be sure to use genuine Yamaha oils, grease and sealers, or the equivalents.



Expendable parts

Always replace the gaskets, O-rings, cotter pins and circlips with new parts when servicing engine.

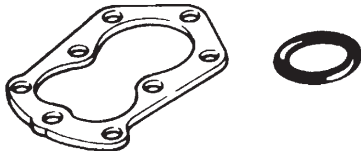

IMPORTANT INFORMATION

1

GENERAL INFORMATION

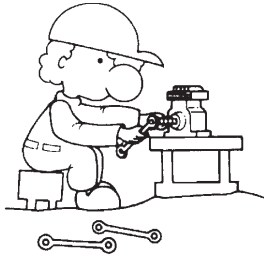

Tightening torque

Be sure to follow torque specifications. When tightening bolts, nuts or screws, start with the largest-diameter fastener and work from an inner position to an outer position in a crisscross pattern.

Notes on disassembly and assembly

- Parts should be cleaned in solvent and blown dry with compressed air after disassembly.

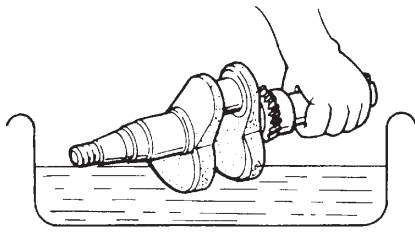

Solvent

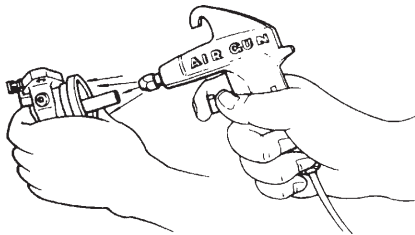

- Contact surfaces of moving parts should be oiled when reassembled.
- Make sure that the parts, move smoothly after each section of the machine is assembled.

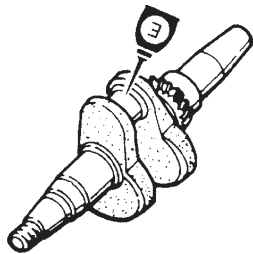

ALL REPLACEMENT PARTS

We recommend the use of genuine Yamaha parts for all replacements. Use oil and/or grease, recommended by Yamaha, for assembly and adjustment.

GASKETS, OIL SEALS, AND O-RINGS

1. All gaskets, seals, and O-rings should be replaced when an engine is overhauled. All gaskets surfaces, oil seal lips, and O-rings must be cleaned.
2. Properly oil all mating parts and bearings during reassembly. Apply grease to the oil seal lips.

BASIC SERVICE INFORMATION

1

GENERAL INFORMATION

BEARINGS AND OIL SEALS

Install the bearing(s) "1" and oil seal(s) "2" with their manufacturer's marks or numbers facing outward. (In other words, the stamped letters must be on the side exposed to view.) When installing oil seal(s), apply a light coating of lightweight lithium base grease to the seal lip(s). Oil the bearings liberally when installing.

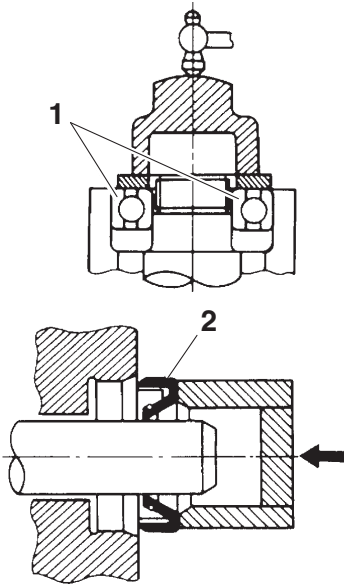

NOTICE

Do not use compressed air to spin the bearings dry. This causes damage to the bearing surfaces.

BASIC SERVICE INFORMATION

ELECTRICAL SYSTEM

Checking the electrical system

TIP

Before checking the electrical system, make sure that the battery voltage is at least 12 V.

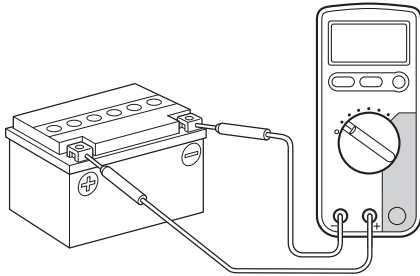

NOTICE

Never insert the tester probes into the coupler terminal slots. Always insert the probes from the opposite end "a" of the coupler, taking care not to loosen or damage the leads.

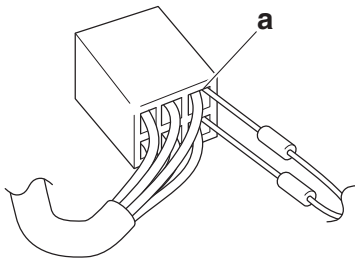

BASIC SERVICE INFORMATION

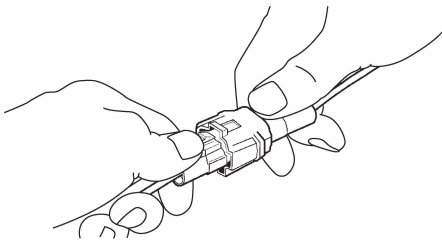

Checking the connections

Check the leads, couplers, and connectors for stains, rust, moisture, etc.

1. Disconnect:
 - Lead
 - Coupler
 - Connector

NOTICE

- When disconnecting a coupler, release the coupler lock, hold both sections of the coupler securely, and then disconnect the coupler.
 - There are many types of coupler locks; therefore, be sure to check the type of coupler lock before disconnecting the coupler.
-

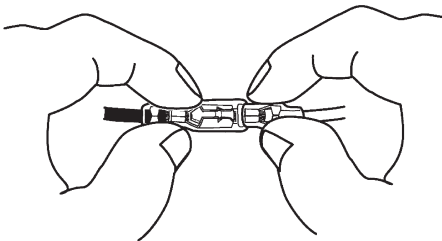

NOTICE

When disconnecting a connector, do not pull the leads. Hold both sections of the connector securely, and then disconnect the connector.

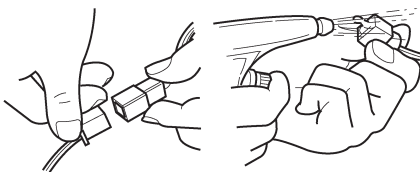

2. Check:
 - Lead
 - Coupler
 - ConnectorMoisture → Dry with an air blower.
Rust/stains → Connect and disconnect several times.

BASIC SERVICE INFORMATION

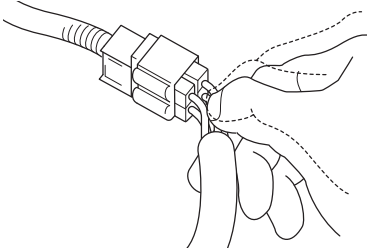
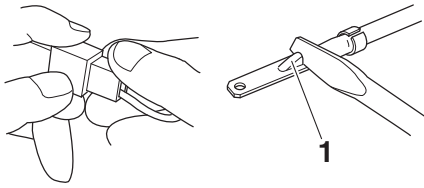

3. Check:

- All connections
- Loose connection → Connect properly.

TIP

- If the pin "1" on the terminal is flattened, bend it up.
 - After disassembling and assembling a coupler, pull on the leads to make sure that they are installed securely.
-

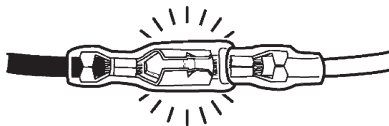
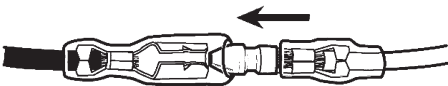
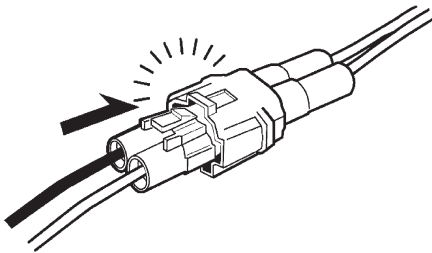

4. Connect:

- Lead
- Coupler
- Connector

TIP

- When connecting a coupler or connector, push both sections of the coupler or connector together until they are connected securely.
 - Make sure all connections are tight.
-

BASIC SERVICE INFORMATION

1

GENERAL INFORMATION

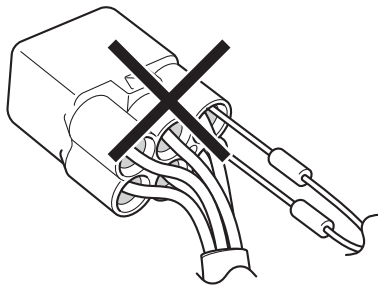
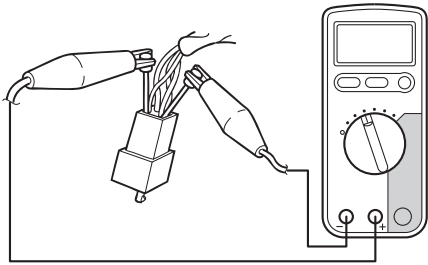
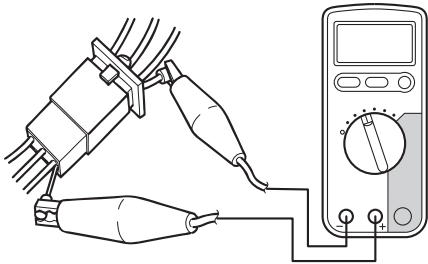

5. Check:

- Continuity
(with the digital circuit tester)



Digital circuit tester (CD732):

90890-03243

Model 88 Multimeter with tachometer:

YU-A1927

TIP

- If there is no continuity, clean the terminals.
- When checking the wire harness, perform steps (1) to (4).
- Make sure to check the connector and coupler of the TCI unit/CDI unit when replacing the TCI unit/CDI unit.
- As a quick remedy, use a contact revitalizer available at most part stores.

NOTICE

For waterproof couplers, never insert the tester leads directly into the coupler. When performing any checks using a waterproof coupler, use the specified test harness or a suitable commercially available test harness.

SPECIAL TOOLS AND TESTERS

SPECIAL TOOLS AND TESTERS

The proper special tools are necessary for complete and accurate tune-up and assembly. Using the correct special tool will help prevent damage caused by the use of improper tools or improvised techniques.

TIP

- For U.S.A. and Canada, use part number starting with “YM-”, “YU-”, or “YS-”.
- For others, use part number starting with “90890-”.

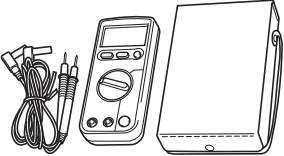
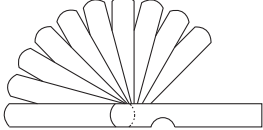
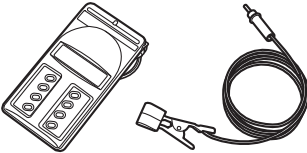
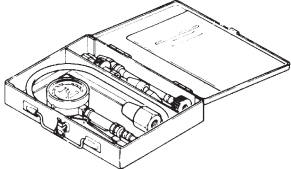
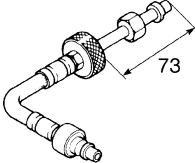
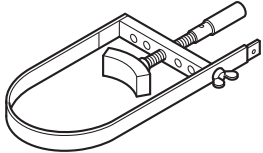
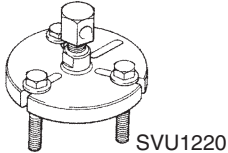
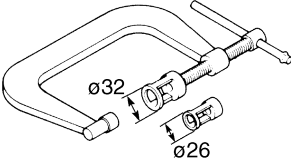
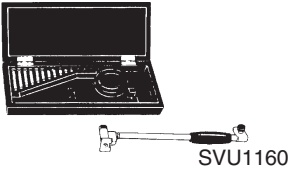
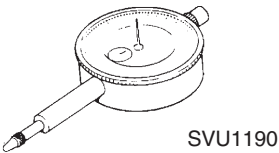
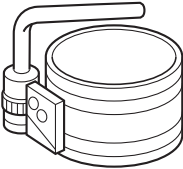
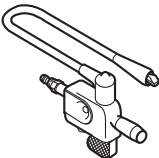
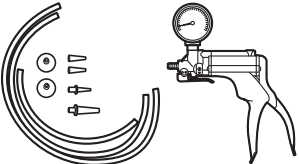
<p>Digital circuit tester (CD732) 90890-03243 Model 88 Multimeter with tachometer YU-A1927</p> 	<p>Thickness gauge 90890-03268 Feeler gauge set YU-26900-9</p> 	<p>Digital tachometer 90890-06760 YU-39951-B</p> 	<p>Compression gauge 90890-03081 Engine compression tester YU-33223</p> 
<p>Compression gauge extension 73mm 90890-04082 YM-04082</p> 	<p>Sheave holder 90890-01701 Primary clutch holder YS-01880-A</p> 	<p>Flywheel puller 90890-01362 Heavy duty puller YU-33270-B</p> 	<p>Valve spring compressor 90890-01253</p> 
<p>Cylinder gauge Commercially obtainable</p> 	<p>Dial gauge 90890-03097 Dial indicator gauge YU-A8428</p> 	<p>Piston ring compressor 90890-05158 YM-08037</p> 	<p>Ignition checker 90890-06754 Oppama pet-4000 spark checker YM-34487</p> 
<p>Vacuum/pressure pump gauge set 90890-06945 Pressure/ vacuum tester YB-35956-B</p> 			

SPECIAL TOOLS AND TESTERS

MEMO

1

GENERAL INFORMATION

PERIODIC CHECKS AND ADJUSTMENTS

INTRODUCTION

This chapter includes all information necessary to perform recommended checks and adjustments. These preventive maintenance procedures, if followed, will ensure more reliable machine operation and a longer service life. The need for costly overhaul work will be greatly reduced. This information applies to machines already in service as well as new machines that are being prepared for sale. All service technicians should be familiar with this entire chapter.

MAINTENANCE INTERVALS CHART

Proper periodic maintenance is important. Especially important are the maintenance services related to emissions control. These controls not only function to ensure air filter but are also vital to proper engine operation and maximum performance.

PERIODIC MAINTENANCE/LUBRICATION INTERVALS

Maintenance Items	Every 8 hours (Daily)	Every 50 hours	Every 200 hours	Every 500 hours	Every 1000 hours
Clean engine and check bolts and nuts	√ (Daily)				
Check for leakage from hoses and fitting	√ (Daily)				
Check and refill engine oil	√ (Refill daily to upper level)				
Change engine oil (*1)	√ (Initial 20 hours)	√ (Every 100 hours)			
Replace engine oil filter (*1)	√ (Initial 20 hours)		√		
Check battery electrolyte fluid level		√			
Clean spark plug		√			
Clean air cleaner		√			
Spark arrester (optional part)		√ (Every 100 hours)			
Replace air cleaner element			√		
Clean fuel strainer			√		
Clean and adjust spark plug and electrodes			√		
Replace spark plug				√	
Remove carbon from cylinder head				√	
Clean carburetor				√	
Clean engine base (oil pan)				√	

PERIODIC MAINTENANCE/LUBRICATION INTERVALS

Maintenance Items	Every 8 hours (Daily)	Every 50 hours	Every 200 hours	Every 500 hours	Every 1000 hours
Check and adjust valve clearance				√	
Replace fuel lines					√ (Every 2 years)
Replace oil lines					√ (Every 2 years)
Overhaul engine					√

*1 Initial oil change and oil filter replacement should be performed after 20 hours of operation. Thereafter change oil every hundred (100) hours and replace oil filter 200 hours. Before changing oil, check for a suitable way to dispose of old oil. Do not pour it down into sewage drains, onto garden soil or into open streams. Your local zoning or environmental regulations will give you more detailed instructions on proper disposal.

*2 More frequent oil changing, oil filter replacement and air cleaner service on replacement may be necessary depending on operating conditions. This would include dusty environment, high ambient temperature, heavy engine loading.

PERIODIC MAINTENANCE

SPARK PLUGS

The following procedure applies to all of the spark plugs.

WARNING

Check and adjust the areas around the cylinder head after the engine has cooled down completely.

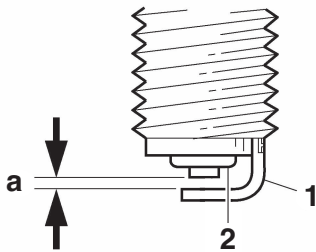
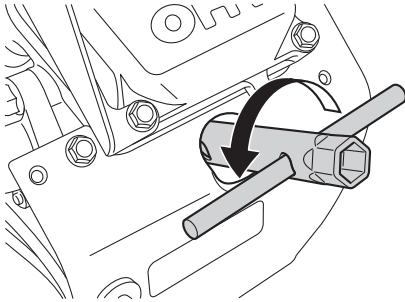

1. Remove:
 - Spark plug cap
 - Spark plug

NOTICE

Before removing the spark plug, use compressed air to clean the cylinder head cover to prevent dirt from falling into the engine.

2. Check:
 - Spark plug type
Not correct → Replace.



Spark plug type:

BPR5ES (NGK) (Except for EH64A)
BPR4EY (NGK) (EH64A)

- Electrode “1”
Wear/damage → Replace.
- Insulator color “2”
Not normal → Replace.

3. Measure:
 - Spark plug gap “a”
Use a wire gauge or thickness gauge.
Out of specification → Adjust.
If necessary, clean the spark plug with a spark plug cleaner.



Thickness gauge:

90890-03268

Feeler gauge set:

YU-26900-9



Spark plug gap:

0.7–0.8 mm (0.028–0.031 in) (Except for EH64A)

0.6–0.7 mm (0.024–0.028 in) (EH64A)

PERIODIC MAINTENANCE

2

PERIODIC CHECKS AND ADJUSTMENTS

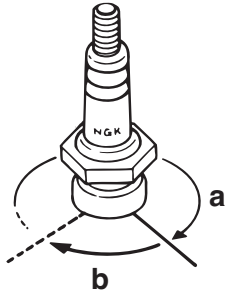

TIP

Before installing the spark plugs, clean the gasket surface and plug surface.

4. Install:

- Spark plug



Spark plug:

13 N·m (1.3 kgf·m, 9.6 lb·ft)

TIP

To prevent threads from being damaged, temporarily tighten the spark plug to position “a” before tightening it to the specified torque “b”.

FUEL LEAKAGE

1. Check:

- Gasoline leakage

Check the fuel pump, fuel hose, and carburetor.

NOTICE

Replace the fuel hose every two years.

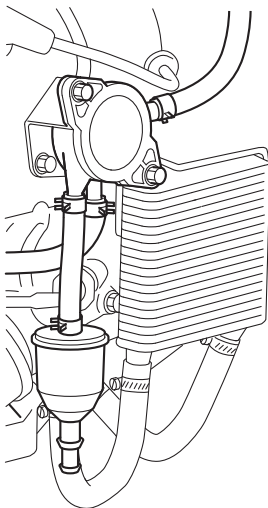

FUEL FILTER

⚠ WARNING

Do not smoke, and keep away from open flames, sparks, or any other source of fire when handling or in the vicinity of fuel.

PERIODIC MAINTENANCE

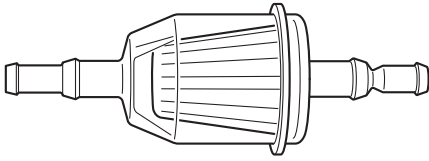

1. Remove:
 - Fuel filter
2. Check:
 - Fuel filter
 - Damage/dirt/clogging → Replace.

NOTICE

Be sure to replace the fuel filter without cleaning it.

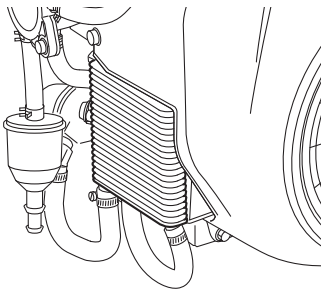

ENGINE OIL LEAKAGE

1. Place the multi-purpose engine on a level surface.
2. Check the areas outside of the engine for oil leakage.
Oil leakage → Replace the gasket, oil seal or O-ring.

ENGINE OIL LEVEL

1. Remove:
 - Oil filler cap "1"
 - Oil level gauge "2"

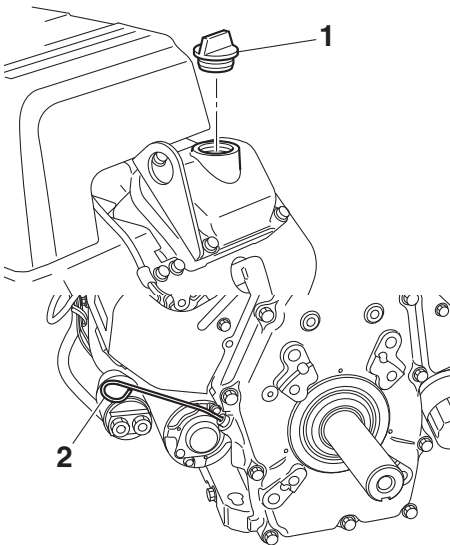

PERIODIC MAINTENANCE

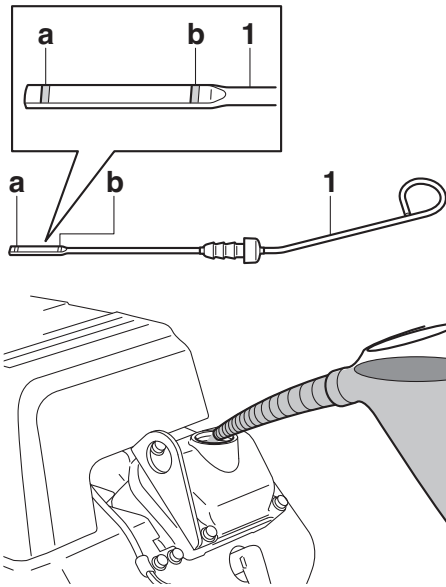

2. Check:

- Check that the engine oil is between the lower limit “a” and the upper limit “b” of the oil level gauge “1”.

Oil level checking steps:

- a. Place the multi-purpose engine on a level surface.
- b. Warm up the engine for several minutes.
- c. Stop the engine.
- d. Remove the oil filler cap.
- e. Remove the oil level gauge “1”, wipe off the level gauge with a rag, etc., then reinsert it as before and remove it.
- f. Check that the engine oil is between the lower limit “a” and the upper limit “b” of the oil level gauge.
Add oil if necessary.

3. Install:

- Oil level gauge
- Oil filler cap

REPLACING THE ENGINE OIL

1. Warm up the engine for several minutes, and then stop the engine.

2. Remove:

- Oil drain bolt “1”
- Oil drain bolt gasket “2”

TIP

This engine is equipped with two oil drain bolts. Use whichever side is accessible.

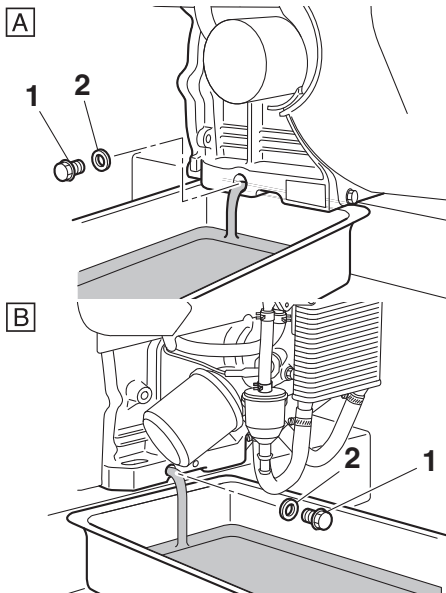

A. EH63K/EH64A/EH64K/EH65A/EH65B

B. EH72A/EH72B/EH72K

3. Drain:

- Engine oil
Place the oil pan under the engine and drain the engine oil.

4. If the oil filter is also to be replaced, perform the following procedure.

PERIODIC MAINTENANCE

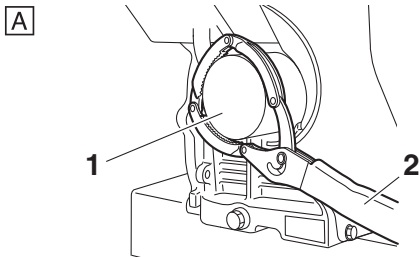

a. Remove the oil filter “1” using an oil filter wrench (commercially available product) “2”.

	Oil filter wrench 65 mm (2.55 in)
--	--

- A. EH63K/EH64A/EH64K/EH65A/EH65B
- B. EH72A/EH72B/EH72K

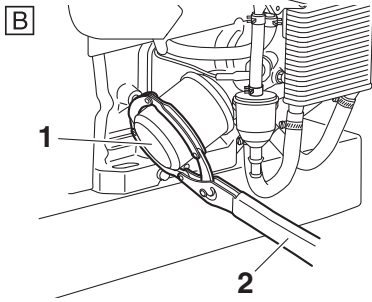

b. Apply a thin layer of engine oil to the O-ring “3” of the new oil filter.

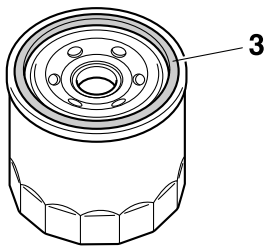

NOTICE

Check that the O-ring “3” is correctly installed in the groove portion of the oil filter.

c. Install the new oil filter and tighten with an oil filter wrench (commercially available product).

	Oil filter: 12 N·m (1.2 kgf·m, 8.9 lb·ft)
--	--

- 5.** Install:
- Oil drain bolt gasket “2” **New**
 - Oil drain bolt “1”

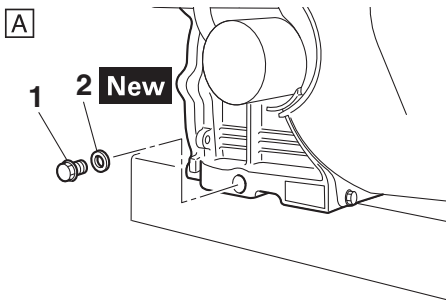

	Oil drain bolt: 21 N·m (2.1 kgf·m, 15 lb·ft)
--	---

- A. EH63K/EH64A/EH64K/EH65A/EH65B
- B. EH72A/EH72B/EH72K

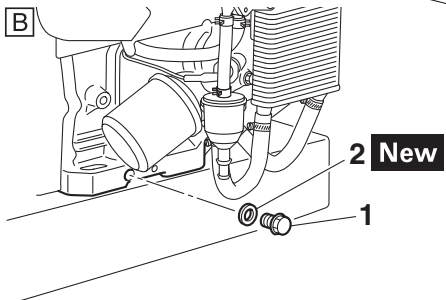

PERIODIC MAINTENANCE

2

PERIODIC CHECKS AND ADJUSTMENTS

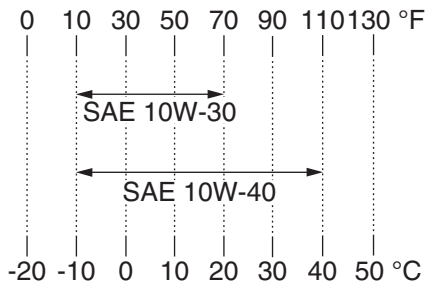

6. Fill:

- Engine oil
Fill the recommended engine oil from the oil filler hole.

	Recommended oil brand: YAMALUBE
	Available oil grade: API SE type or higher JASO MA or MB
	Available viscosity index: 10W-30 or 10W-40
	Engine oil quantity: 1.55 L (1.64 US qt, 1.36 Imp.qt)

7. Check:

- Engine oil level
(Refer to “ENGINE OIL LEVEL” on page 2-5.)

OIL COOLER (EH72A/EH72B/EH72K)

1. Check:

- Oil cooler
Damage → Replace.
Dirt/clog → Clean.

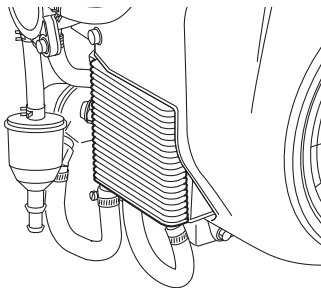

AIR FILTER ELEMENT

NOTICE

Be sure not to run the engine without air filter element. Otherwise this can result in excessive piston and/or cylinder wear.

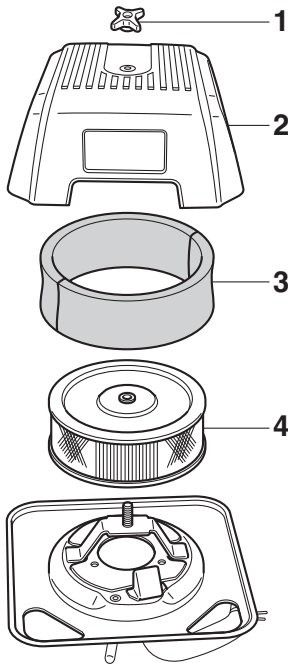

Standard

1. Remove:
 - Air filter cover nut “1”
 - Air filter cover “2”
2. Remove:
 - Air filter element “3”
 - Inner element “4”

3. Check:
 - Air filter element

Damage → Replace.
Clogged → Wash the element with white kerosene, then dry it thoroughly.
Oil the element and squeeze out the excess oil.

! WARNING

Do not wash the element with gasoline or with acidic, alkalic, or organic solvents.

NOTICE

Do not wring out the element. This could cause it to tear.

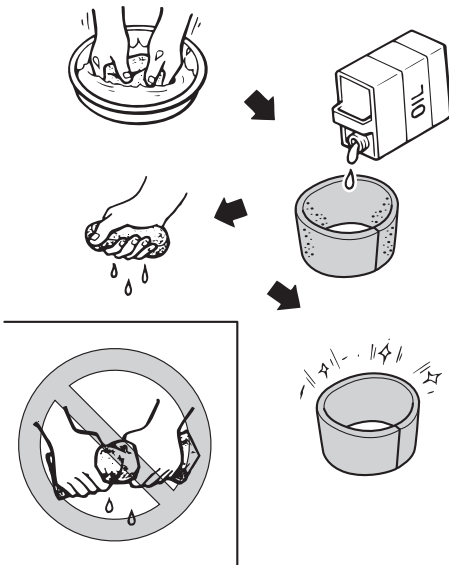

4. Check:
 - Inner element

Damage → Replace.
Clogged → Either tap lightly or blow air from the inside of the element to blow the dust off.

NOTICE

- Do not wash the inner element with white kerosene, gasoline or oil, or acidic, alkaline or organic solvents.
- Replace the inner element if it is too dirty.

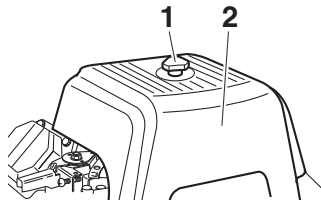

5. Install:
 - Inner element
 - Air filter element
 - Air filter cover
 - Air filter cover nut

Optional

1. Remove:
 - Air filter cover nut "1"
 - Air filter cover "2"

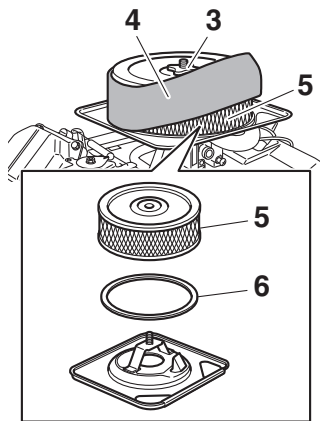

2. Remove:
 - Element nut "3"
 - Air filter element "4"
 - Inner element "5"
 - Element seal "6"

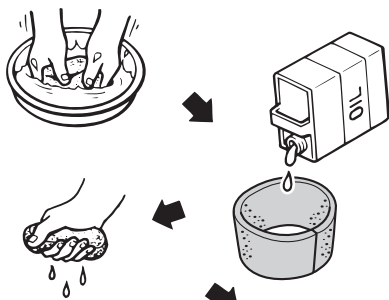

3. Check:
 - Air filter element
 - Damage → Replace.
 - Clogged → Wash the element with white kerosene, then dry it thoroughly.
 - Oil the element and squeeze out the excess oil.

! WARNING
 Do not wash the element with gasoline or with acidic, alkalic, or organic solvents.

NOTICE
 Do not wring out the element. This could cause it to tear.

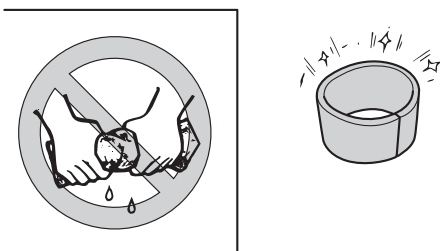

4. Check:

- Inner element
Damage → Replace.
Clogged → Either tap lightly or blow air from the inside of the element to blow the dust off.

NOTICE

- Do not wash the inner element with white kerosene, gasoline or oil, or acidic, alkaline or organic solvents.
- Replace the inner element if it is too dirty.

5. Install:

- Element seal
- Inner element
- Air filter element
- Element nut
- Air filter cover
- Air filter cover nut

MUFFLER

! WARNING

The engine and muffler will be very hot after the engine has been run.

Avoid touching the engine and muffler while they are still hot with any part of your body or clothing during check or repair.

1. Remove:

- Muffler cap screw "1"
- Muffler cap "2"

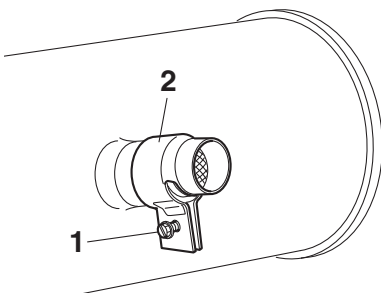

2. Remove:

- Spark arrester "1"

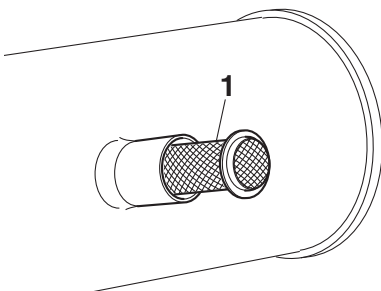

3. Remove:

- Muffler
(Refer to "MUFFLER" on page 3-5.)

PERIODIC MAINTENANCE

2

PERIODIC CHECKS AND ADJUSTMENTS

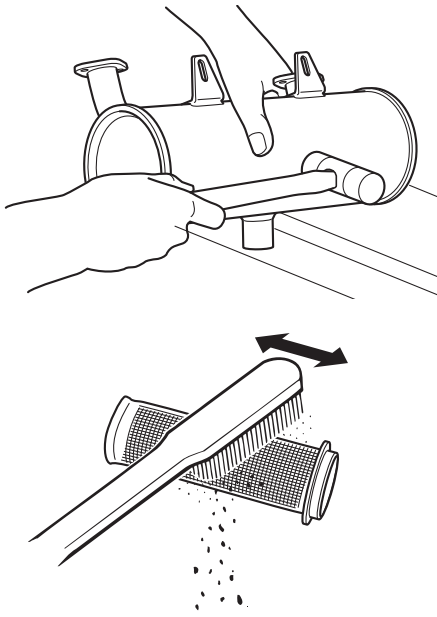

4. Decarbonize:

- Muffler

Tap on the muffler in the area shown in the illustration to loosen carbon buildup, and then shake it out from the end of the muffler.

5. Decarbonize:

- Spark arrester

NOTICE

When cleaning with a wire brush, use it softly to avoid damage or scratch the spark arrester.

6. Install:

- Muffler

(Refer to “INSTALLING THE MUFFLER” on page 3-9.)

- Spark arrester
- Muffler cap
- Muffler cap screw

BREATHER HOSE

1. Check:

- Breather hose “1”
Crack/damage → Replace.
Poor connection → Connect.

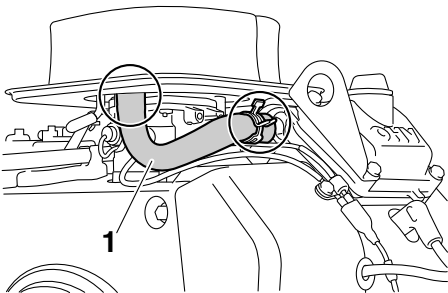

CYLINDER HEAD DECARBONIZATION

The following procedure applies to all of the cylinder heads.

1. Remove:

- Cylinder head assembly
(Refer to “CYLINDER HEAD COVERS, CYLINDER HEADS” on page 3-26.)

2. Eliminate:

- Carbon deposits
(Refer to “CHECKING THE CYLINDER HEADS” on page 3-32.)

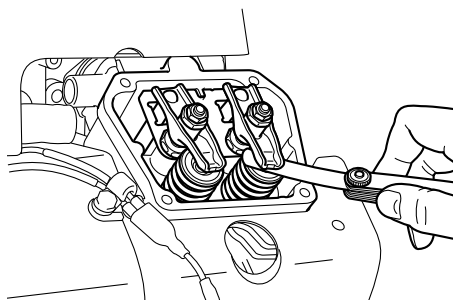
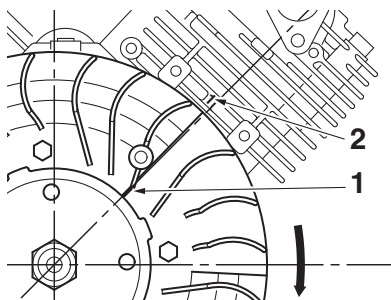
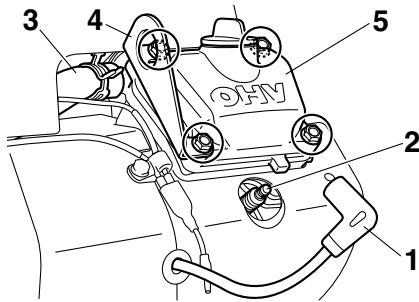

3. Install:
 - Cylinder head assembly
(Refer to “INSTALLING THE CYLINDER HEAD ASSEMBLIES” on page 3-33.)

ADJUSTING THE VALVE CLEARANCE

The following procedure applies to all of the valves.

1. Remove:
 - Spark plug cap “1”
 - Spark plug “2”

NOTICE

Before removing the spark plug, use compressed air to clean the cylinder head cover to prevent dirt from falling into the engine.

2. Remove:
 - Breather hose “3”
 - Engine hanger “4”
 - Cylinder head cover “5”
 - Cylinder head cover gasket
3. Turn the crankshaft clockwise and then set the piston at TDC (top-dead-center) on the compression stroke.

TIP

- Rotate the crankshaft until the “1” mark “1” of the flywheel is lined up with the “1” mark “2” of cylinder head #1.
- For the cylinder head #2 side as well, rotate the crankshaft until the “1” mark of the flywheel and the “2” mark of cylinder head #2 match.

4. Measure:
 - Valve clearance
(Between the rocker arm and valve stem end)
Out of specification → Adjust.

TIP

Valve clearance must be measured when the engine has cooled down enough to be touched.



Thickness gauge:
90890-03268
Feeler gauge set:
YU-26900-9



Valve clearance (cold):
0.07–0.13 mm (0.0027–0.0051 in)

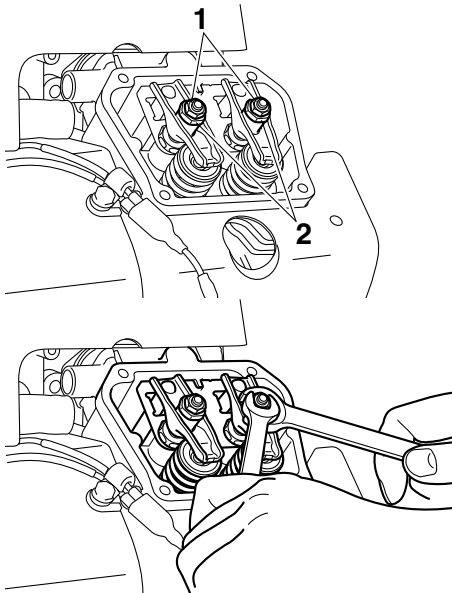

- 5.** Adjust:
- Valve clearance

Adjustment steps:

- Loosen the locknut “1” and insert the thickness gauge between the rocker arm and the valve stem end.
- Return or tighten the adjuster “2” and set the valve clearance to the correct value. Move the thickness gauge up and down to check for the proper resistance.

	Thickness gauge: 90890-03268 Feeler gauge set: YU-26900-9
--	--

Adjuster	Valve clearance
Clockwise	Clearance decreases
Counterclockwise	Clearance increases

- Tighten the locknut “1”.

	Valve adjuster locknut: 8 N·m (0.8 kgf·m, 5.9 lb·ft)
--	---

- 6.** Install:
- Cylinder head cover gasket **New**
 - Cylinder head cover
 - Engine hanger

	Cylinder head cover bolt: 8 N·m (0.8 kgf·m, 5.9 lb·ft)
--	---

- Breather hose
- Spark plug

	Spark plug: 13 N·m (1.3 kgf·m, 9.6 lb·ft)
--	--

- Spark plug cap

ENGINE SPEED (EH63K/EH64A/EH64K/EH65A/EH65B)

1. Warm up the engine for several minutes.
2. Remove:
 - Air filter cover "1"
(Refer to "AIR FILTER" on page 3-3.)

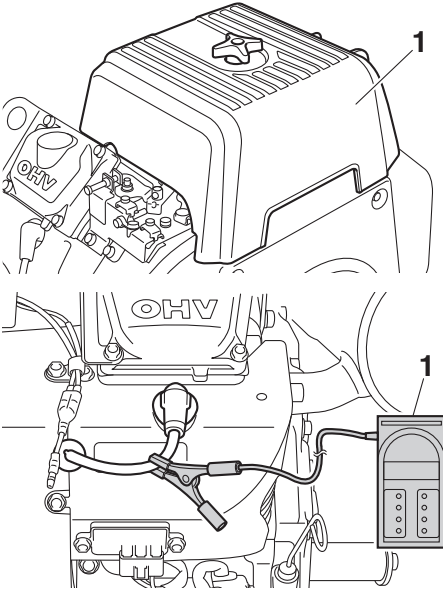

3. Attach:
 - Digital tachometer "1"

	Digital tachometer: 90890-06760, YU-39951-B
---	--

4. Measure:
 - High engine speed (with no load)
Out of specification → Adjust.

	High engine speed: 3200–3400 r/min
---	---

Measurement steps:

- a. Move the throttle lever "1" to the high engine speed position "a".
- b. Check that the high engine speed is the specified value.

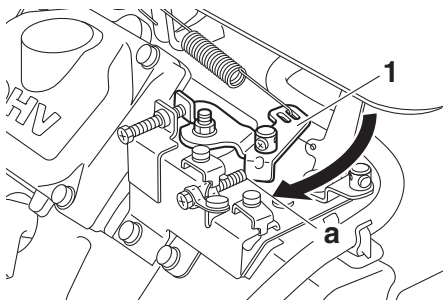

5. Measure:
 - Low engine speed (with no load)
Out of specification → Adjust.

	Low engine speed: 1500–1700 r/min
---	--

PERIODIC MAINTENANCE

2

PERIODIC CHECKS AND ADJUSTMENTS

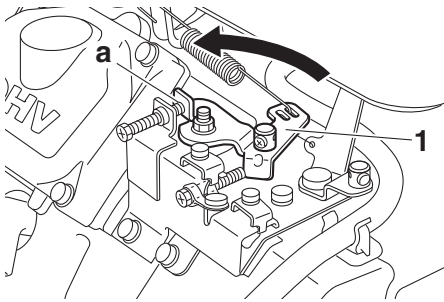

Measurement steps:

- a. Move the throttle lever "1" to the low engine speed position "a".
- b. Check that the low engine speed is the specified valued.

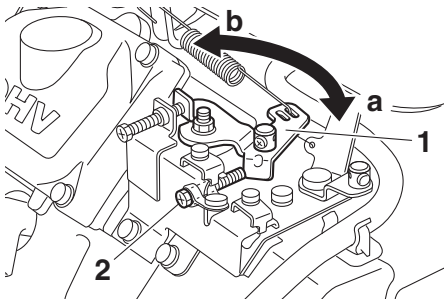

6. Adjust:

- High engine speed

Adjustment steps:

- a. Start the engine.
- b. Set the engine speed to the specified value with the throttle lever. Move the throttle lever "1" in the direction "a" or "b" until the high engine speed reaches the specified value with no load on the engine.

	High engine speed: 3200–3400 r/min
--	--

Direction "a" High engine speed is increased. Direction "b" High engine speed is decreased.
--

- c. Hold the throttle lever at the position where the high engine speed reached the specified value, then turn the screw "2" until it comes in contact with the throttle lever and serves as a stopper.

7. Adjust:

- Low engine speed

Adjustment steps:

- a. Start the engine.
- b. Check that the governor arm "1" is not pulled by the spring "2".

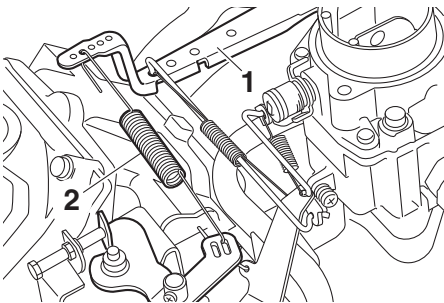

PERIODIC MAINTENANCE

2

PERIODIC CHECKS AND ADJUSTMENTS

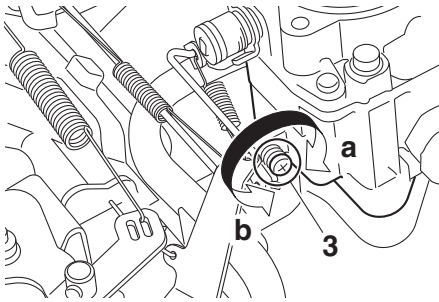

- c. Move the carburetor's throttle stop screw "3" in the direction "a" or "b" until the low engine speed reaches 1300–1500 r/min with no load on the engine.

Direction "a" Low engine speed is increased. Direction "b" Low engine speed is decreased.
--

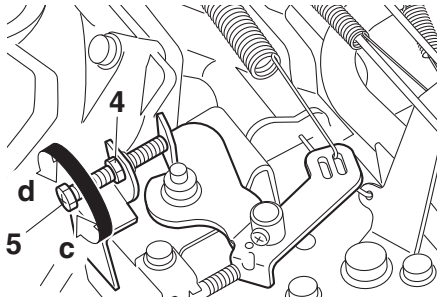

- d. Loosen the locknut "4" and move the screw "5" in the direction "c" or "d" until the low engine speed reaches the specified value.

	Low engine speed: 1500–1700 r/min
--	---

Direction "c" Low engine speed is increased. Direction "d" Low engine speed is decreased.
--

- e. Tighten the locknut "4".

ENGINE SPEED (EH72A/EH72B/EH72K)

1. Warm up the engine for several minutes.
2. Remove:
 - Air filter cover "1"
 (Refer to "AIR FILTER" on page 3-3.)

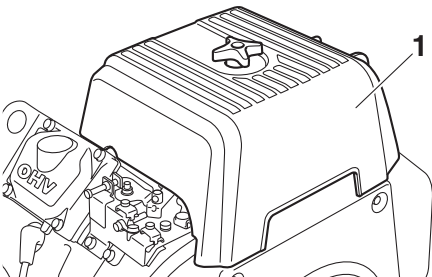

3. Attach:
 - Digital tachometer "1"

	Digital tachometer: 90890-06760, YU-39951-B
--	---

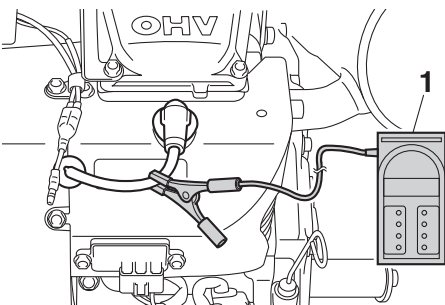

4. Measure:
 - High engine speed (with no load)
 Out of specification → Adjust.

	High engine speed: 3100–3300 r/min
--	--

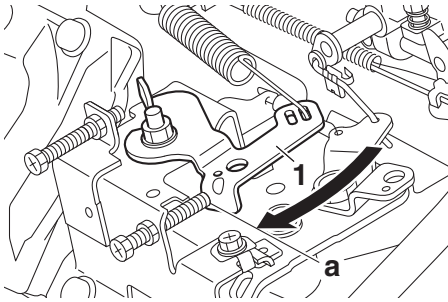

Measurement steps:

- a. Move the throttle lever “1” to the high engine speed position “a”.
- b. Check that the high engine speed is the specified valued.

5. Measure:

- Low engine speed (with no load)
Out of specification → Adjust.

	Low engine speed: 1900–2100 r/min
--	--

Measurement steps:

- a. Move the throttle lever “1” to the low engine speed position “a”.
- b. Check that the low engine speed is the specified valued.

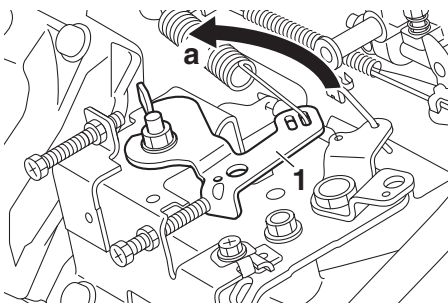

6. Adjust:

- High engine speed

Adjustment steps:

- a. Start the engine.
- b. Set the engine speed to the specified value with the throttle lever. Move the throttle lever “1” in the direction “a” or “b” until the high engine speed reaches the specified value with no load on the engine.

	High engine speed: 3100–3300 r/min
--	---

Direction “a” High engine speed is increased. Direction “b” High engine speed is decreased.
--

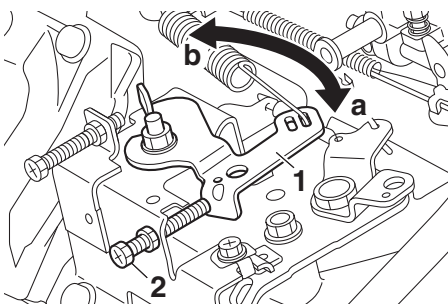

- c. Hold the throttle lever at the position where the high engine speed reached the specified value, then turn the screw “2” until it comes in contact with the throttle lever and serves as a stopper.

- 7.** Adjust:
- Low engine speed

Adjustment steps:

- a. Start the engine.
- b. Check that the governor arm "1" is not pulled by the spring "2".

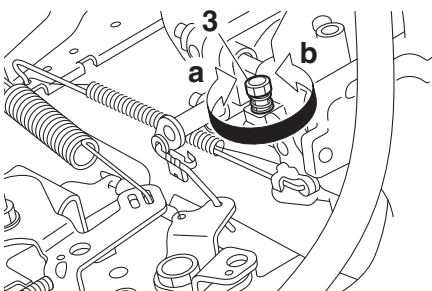
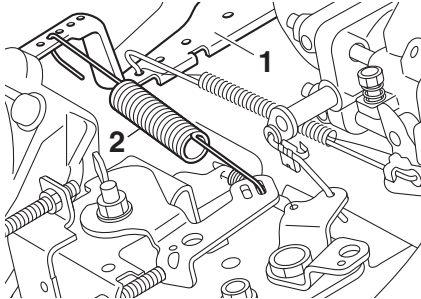

- c. Move the carburetor's throttle stop screw "3" in the direction "a" or "b" until the low engine speed reaches 1900–2100 r/min with no load on the engine.

Direction "a" Low engine speed is increased. Direction "b" Low engine speed is decreased.
--

FITTINGS AND FASTENERS

- 1.** Check:
- All fittings and fasteners
Loose → Tighten.
Rough movement → Replace the defective part(s).
Damage/pitting → Replace.

PERIODIC MAINTENANCE

MEMO

2

PERIODIC CHECKS AND ADJUSTMENTS

ENGINE

ENGINE INSPECTION

MEASURING THE COMPRESSION PRESSURE

The following procedure applies to all of the cylinder heads.

TIP

Measure the compression pressure after checking and adjusting the valve clearance.

1. Warm up the engine for several minutes.
2. Remove:
 - Spark plug cap
 - Spark plug

NOTICE

Before removing the spark plug, use compressed air to clean the cylinder head cover to prevent dirt from falling into the engine.

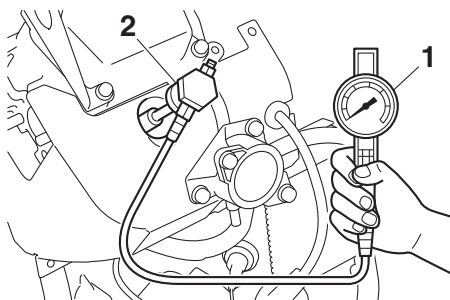

3. Connect:
 - Compression gauge "1"
 - Compression gauge extension 73mm "2"

	Compression gauge: 90890-03081
	Engine compression tester: YU-33223
	Compression gauge extension 73mm: 90890-04082, YM-04082

4. Measure:
 - Compression pressureCrank the engine until the needle stop rising on the compression gauge.
Out of specification → Refer to the testing steps.

	Standard compression pressure: 1200 kPa (12 kg/cm ² , 174 psi)
---	---

⚠ WARNING

To prevent sparking when cranking the engine, ground the high tension cord.

Testing steps (below the minimum specification):

- a. Squirt a few drops of oil into the cylinder.
- b. Measure the compression again.

Reading	Diagnosis
Higher than without oil	<ul style="list-style-type: none"> • Worn cylinder, piston, and piston ring(s)
Same as without oil	<ul style="list-style-type: none"> • Defective piston, piston ring(s), valve(s), and cylinder head gasket • Improper valve timing and valve clearance

Testing steps (above the maximum specification):

- a. Check the cylinder head, valve surfaces, and piston crown for carbon deposits.
Carbon deposits → Eliminate.

5. Install:

- Spark plug

	<p>Spark plug: 13 N·m (1.3 kgf·m, 9.6 lb·ft)</p>
---	--

- Spark plug cap

AIR FILTER

AIR FILTER

EH63K/EH64A/EH64K/EH65A/EH65B

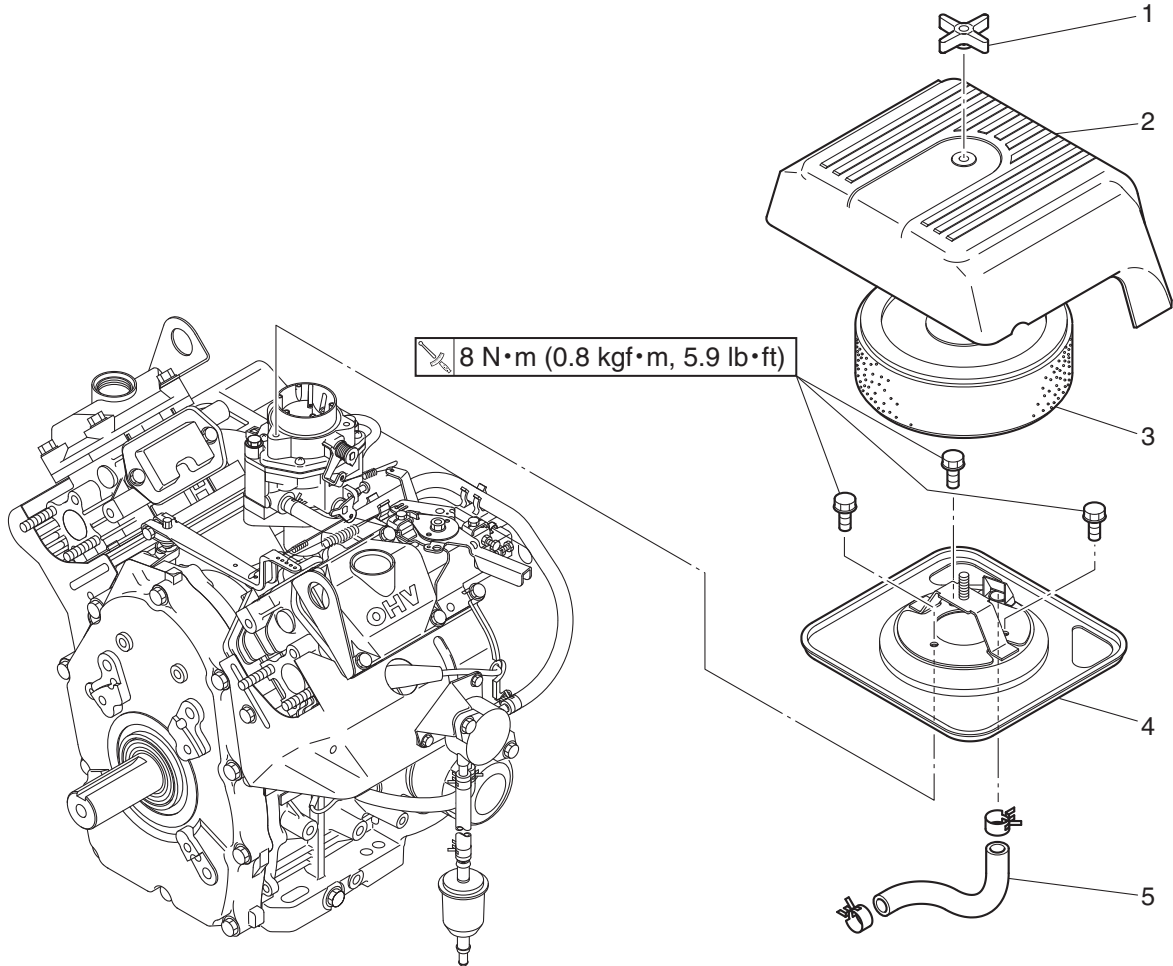

Order	Job/Parts to remove	Q'ty	Remarks
	Removing the air filter		Remove the parts in the order listed.
1	Air filter cover nut	1	
2	Air filter cover	1	
3	Air filter element	1	
4	Air filter plate	1	
5	Breather hose	1	

AIR FILTER

EH72A/EH72B/EH72K

ENGINE

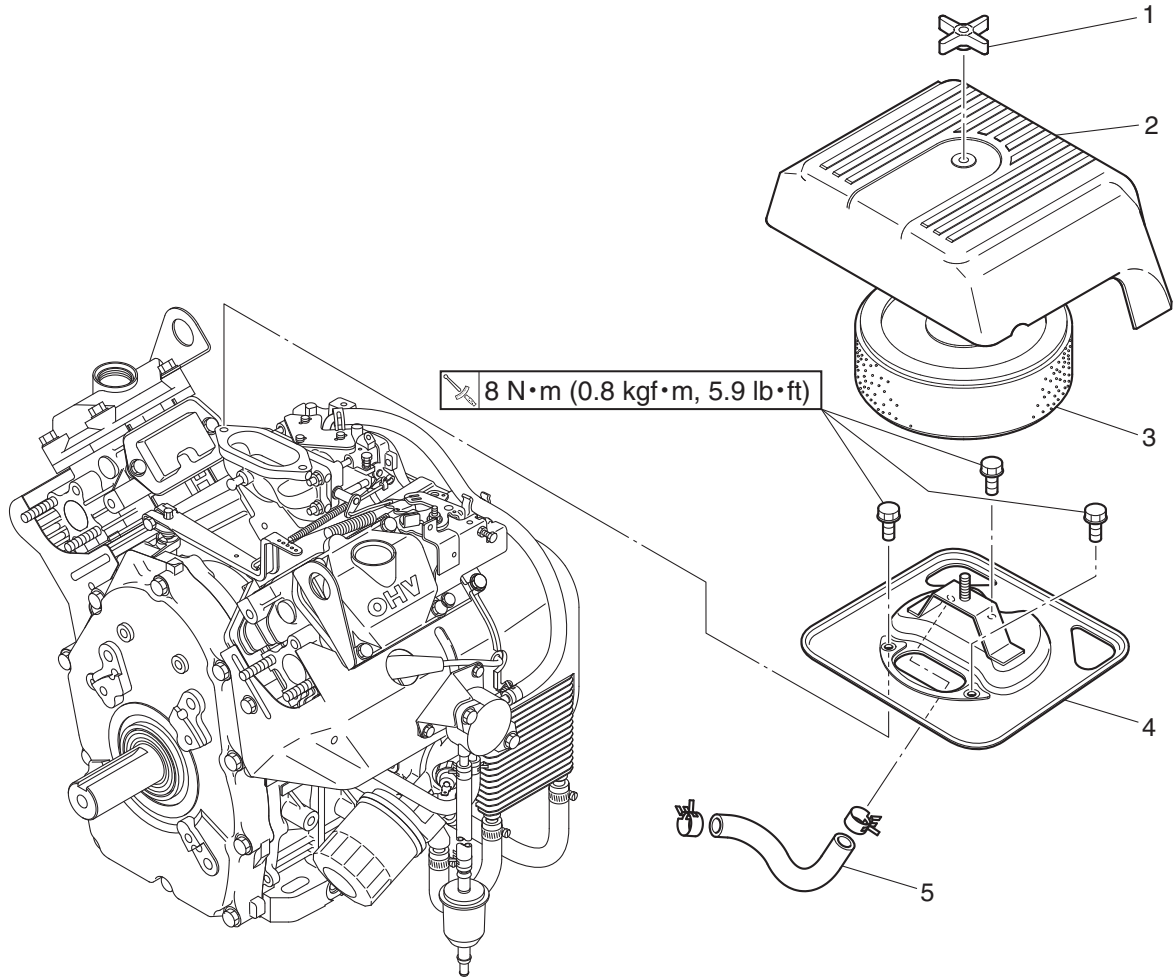

Order	Job/Parts to remove	Q'ty	Remarks
	Removing the air filter		Remove the parts in the order listed.
1	Air filter cover nut	1	
2	Air filter cover	1	
3	Air filter element	1	
4	Air filter plate	1	
5	Breather hose	1	

MUFFLER

MUFFLER

EH63K/EH72B/EH72K

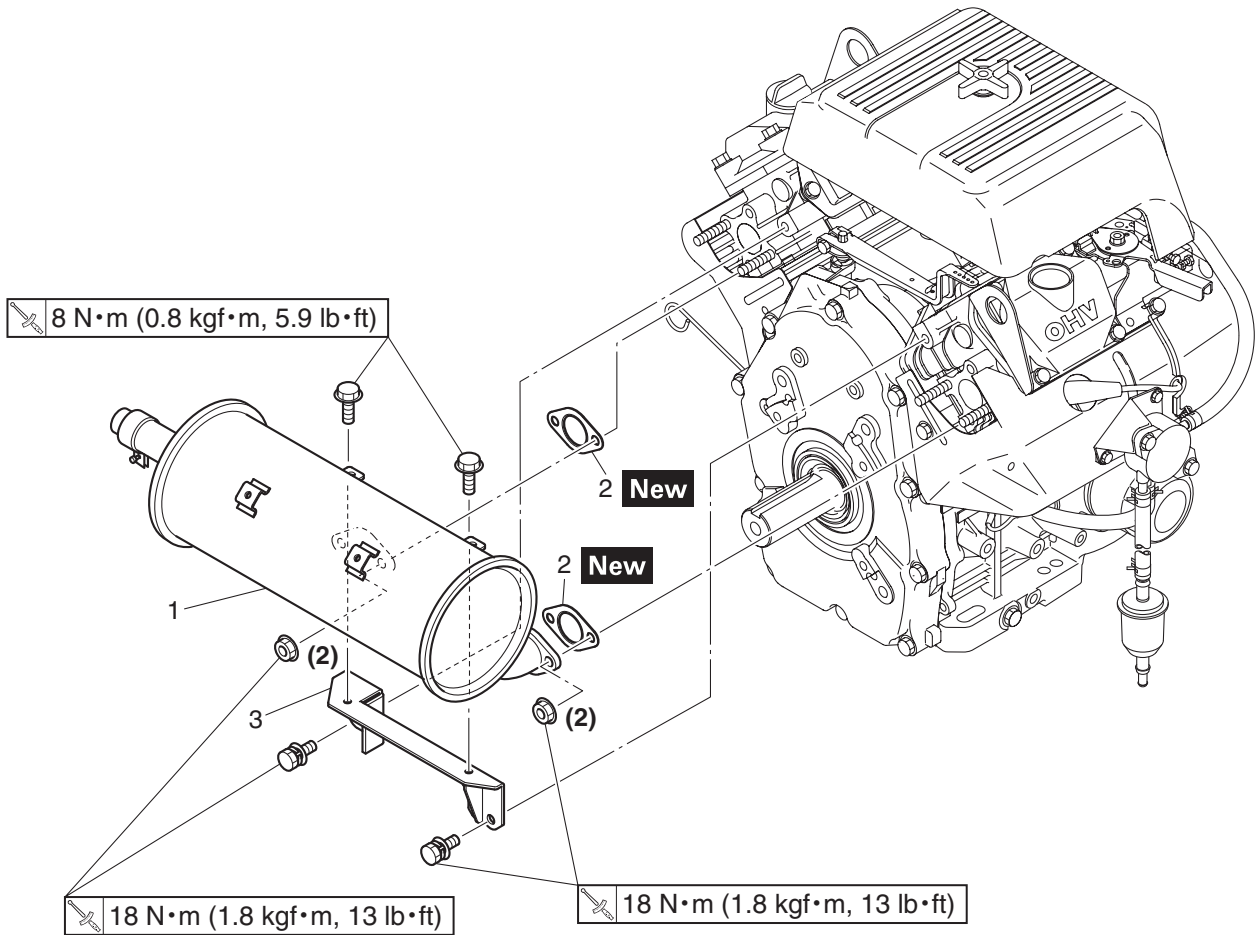

Order	Job/Parts to remove	Q'ty	Remarks
	Removing the muffler		Remove the parts in the order listed.
1	Muffler	1	
2	Gasket	2	
3	Muffler bracket	1	

MUFFLER

EH64K

ENGINE

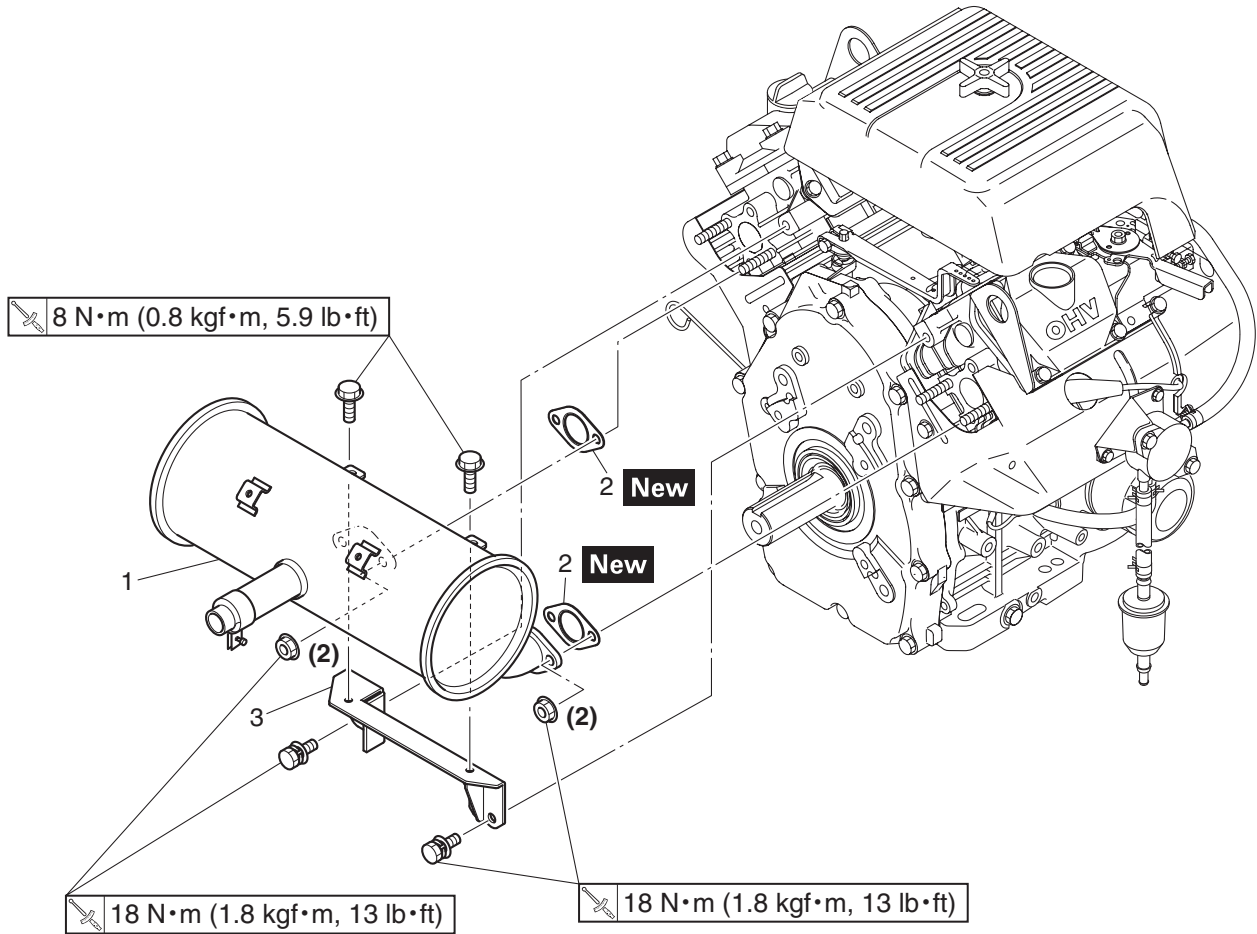

Order	Job/Parts to remove	Q'ty	Remarks
	Removing the muffler		Remove the parts in the order listed.
1	Muffler	1	
2	Gasket	2	
3	Muffler bracket	1	

MUFFLER

EH65B

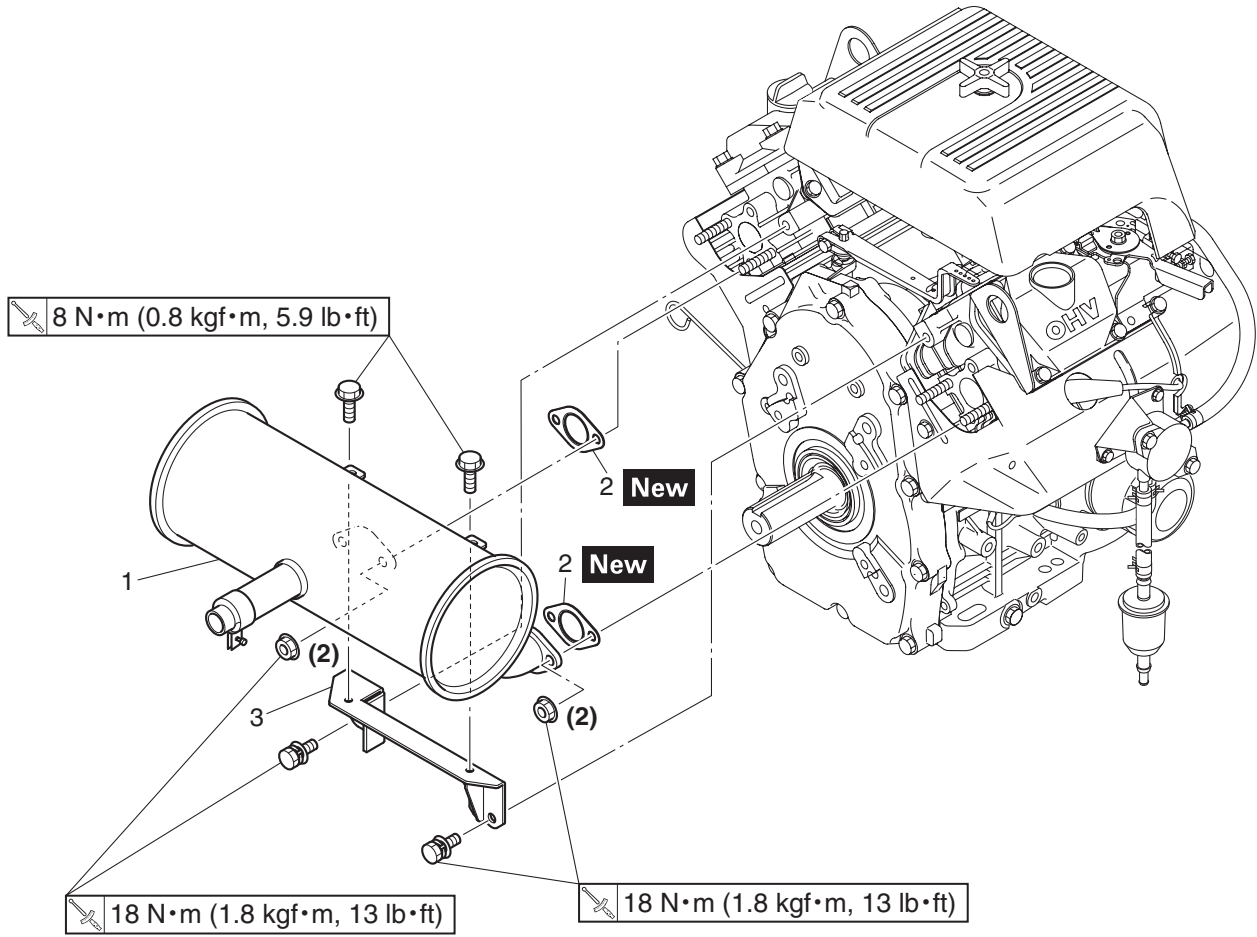

Order	Job/Parts to remove	Q'ty	Remarks
	Removing the muffler		Remove the parts in the order listed.
1	Muffler	1	
2	Gasket	2	
3	Muffler bracket	1	

MUFFLER

EH65A/EH72A

ENGINE 3

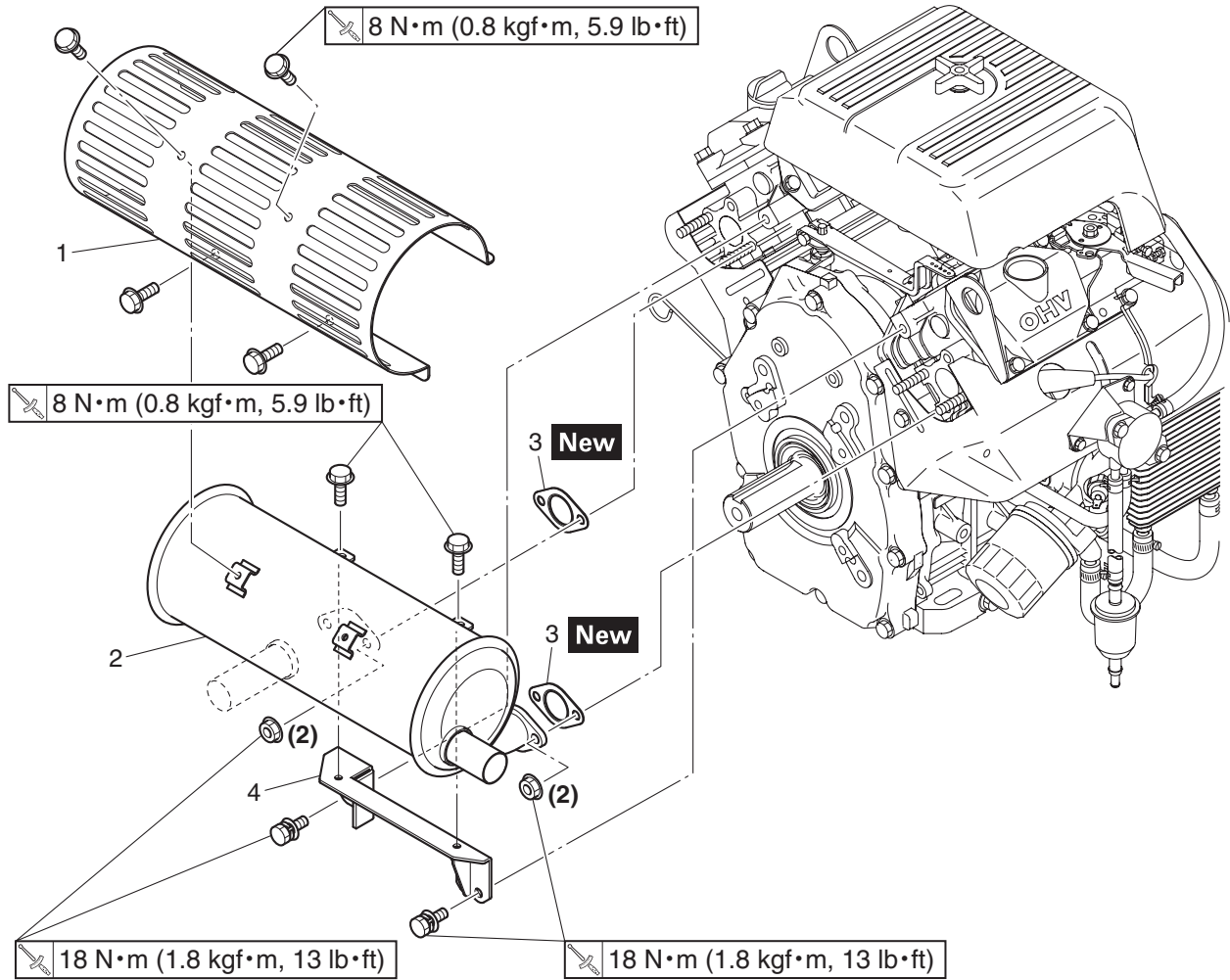

Order	Job/Parts to remove	Q'ty	Remarks
	Removing the muffler		Remove the parts in the order listed.
1	Muffler cover	1	
2	Muffler	1	
3	Gasket	2	
4	Muffler bracket	1	

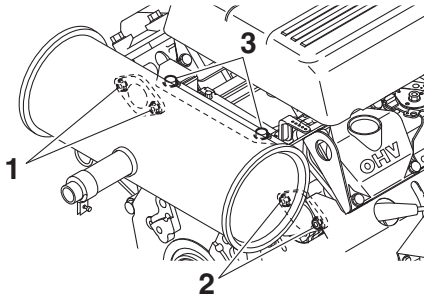

INSTALLING THE MUFFLER

1. Install:
 - Gasket **New**
 - Muffler assembly
 - Muffler nut "1"
 - Muffler nut "2"
 - Muffler bolt "3"

TIP

Temporarily tighten muffler nut "1", muffler nut "2" and muffler bolt "3".

2. Tighten:
 - Muffler nut "1"
 - Muffler nut "2"



Muffler nut:
18 N·m (1.8 kgf·m, 13 lb·ft)

- Muffler bolt "3"



Muffler bolt:
8 N·m (0.8 kgf·m, 5.9 lb·ft)

TIP

Tighten the nuts and bolt to the specified torque in order of muffler nut "1", muffler nut "2", and muffler bolt "3".

OIL COOLER AND OIL FILTER

OIL COOLER AND OIL FILTER

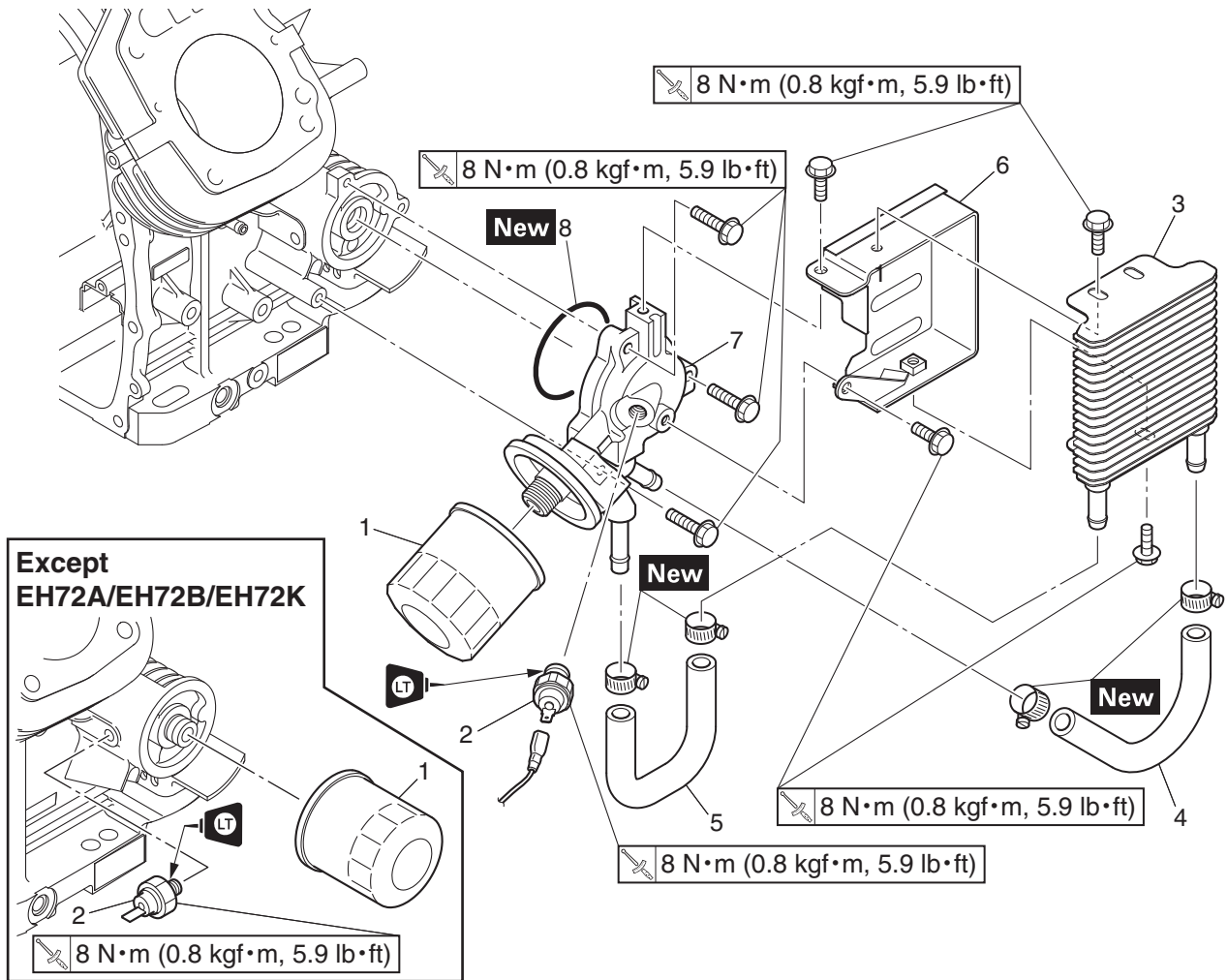

Order	Job/Parts to remove	Q'ty	Remarks
	Removing the oil cooler and oil filter		Remove the parts in the order listed.
	Engine oil		Drain. Refer to "REPLACING THE ENGINE OIL" on page 2-6.
1	Oil filter	1	
2	Oil pressure switch	1	
3	Oil cooler	1	EH72A/EH72B/EH72K
4	Oil hose 1	1	EH72A/EH72B/EH72K
5	Oil hose 2	1	EH72A/EH72B/EH72K
6	Bracket	1	EH72A/EH72B/EH72K
7	Adapter	1	EH72A/EH72B/EH72K
8	O-ring	1	EH72A/EH72B/EH72K

REMOVING THE OIL COOLER (EH72A/EH72B/EH72K)

1. Remove:
 - Oil hose 1
 - Oil hose 2
 - Oil cooler
 - Adapter
 - Oil pressure switch

CHECKING THE OIL COOLER (EH72A/EH72B/EH72K)

1. Check:
 - Oil cooler "1"
 - Oil hose 1 "2"
 - Oil hose 2 "3"
 - Adapter "4"Damage → Replace.
Dirt/clog → Clean.

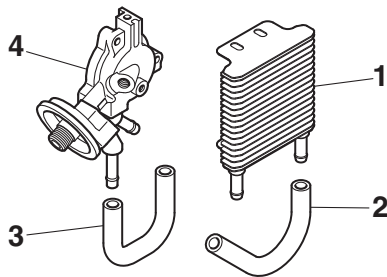

INSTALLING THE OIL COOLER (EH72A/EH72B/EH72K)

1. Clean:
 - Mating surface of adapter and crankcase
(Wipe off with a rag to which solvent has been applied.)
2. Install:
 - O-ring "1" **New**
 - Adapter "2"

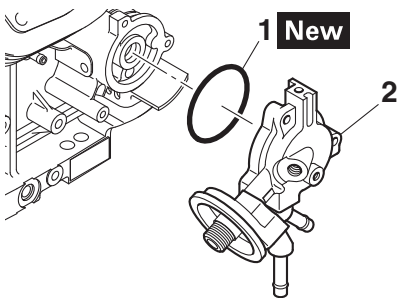

	Adapter bolt: 8 N·m (0.8 kgf·m, 5.9 lb·ft)
---	--

OIL COOLER AND OIL FILTER

3. Install:

- Bracket

	Bracket bolt: 8 N·m (0.8 kgf·m, 5.9 lb·ft)
---	---

- Oil cooler

	Oil cooler bolt: 8 N·m (0.8 kgf·m, 5.9 lb·ft)
---	--

- Oil hose 2
- Oil hose 1
- Oil filter
- Oil pressure switch

	Oil pressure switch: 8 N·m (0.8 kgf·m, 5.9 lb·ft)
---	--

RECTIFIER/REGULATOR

RECTIFIER/REGULATOR

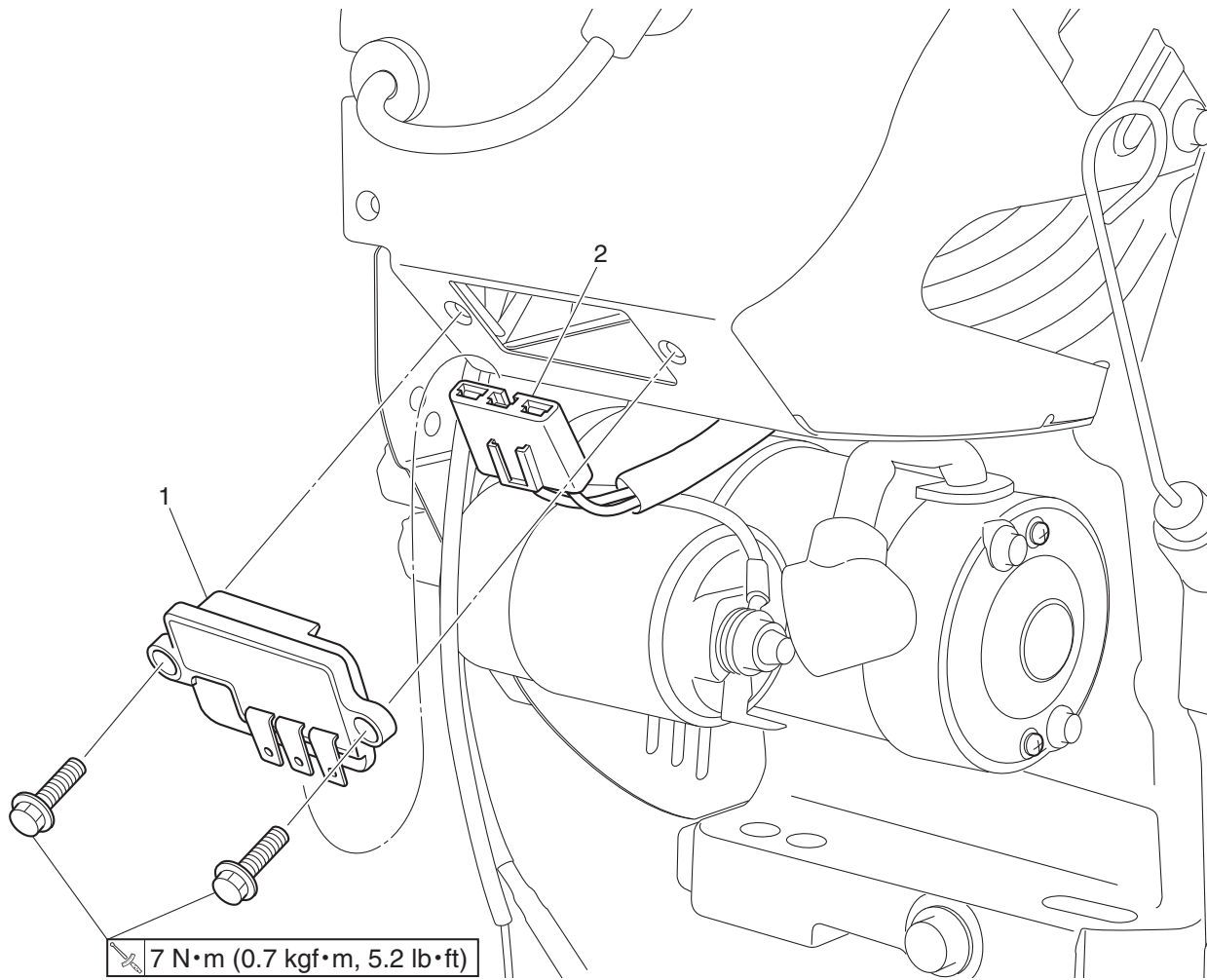

Order	Job/Parts to remove	Q'ty	Remarks
	Removing the rectifier/regulator		Remove the parts in the order listed.
1	Rectifier/regulator	1	
2	Connector	1	Disconnect.

CASE AND FAN

CASE AND FAN

ENGINE 3

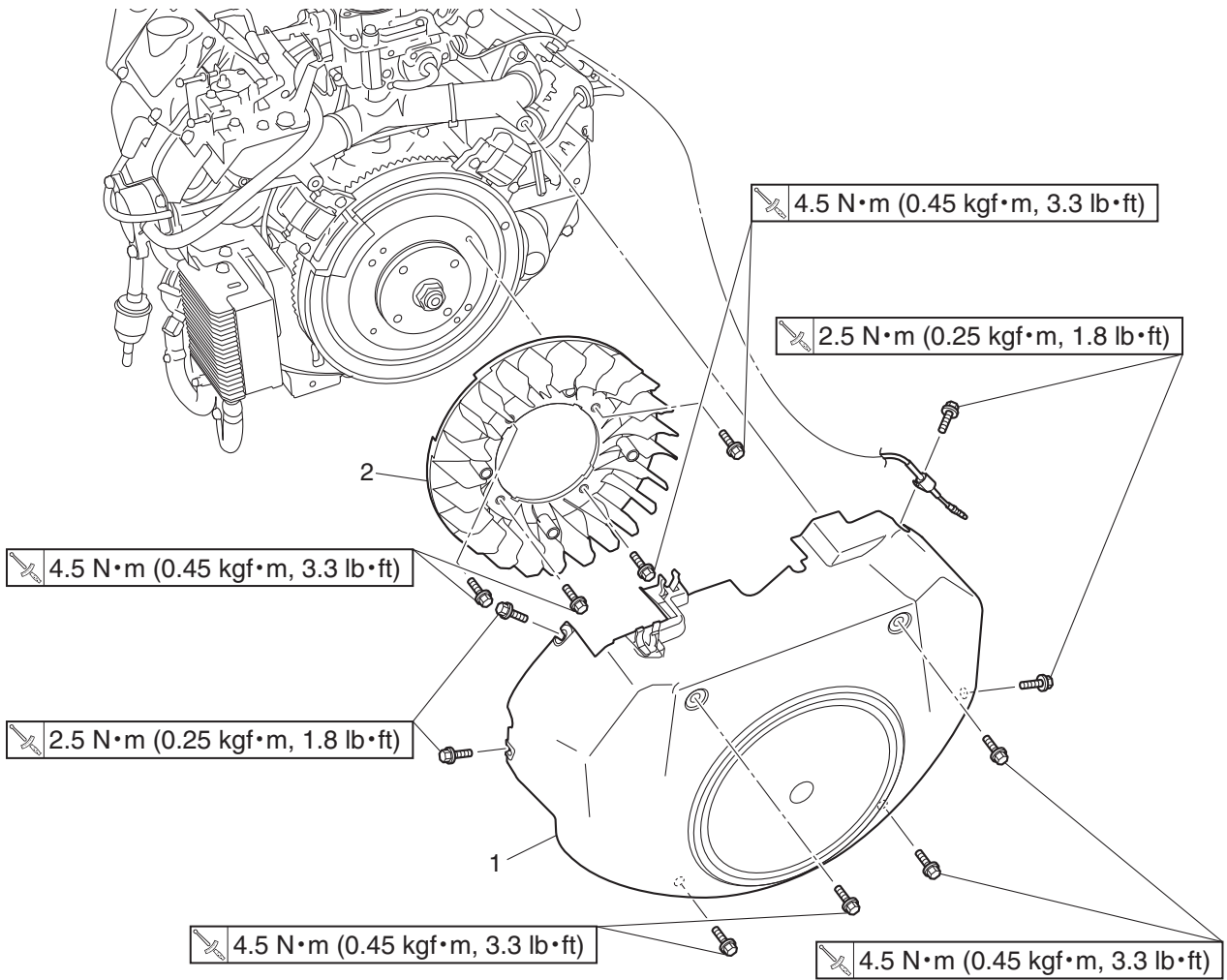

Order	Job/Parts to remove	Q'ty	Remarks
	Removing the case and fan		Remove the parts in the order listed.
	Air filter		Refer to "AIR FILTER" on page 3-3.
1	Fan case	1	
2	Fan	1	

REMOVING THE CASE AND FAN

1. Remove:
 - Air filter
(Refer to "AIR FILTER" on page 3-3.)
2. Remove:
 - Fan case "1"
 - Fan "2"

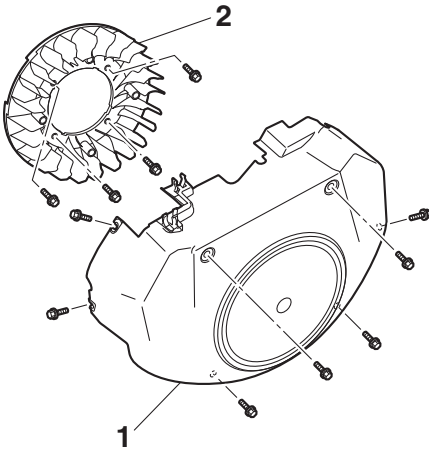

CHECKING THE CASE AND FAN

1. Check:
 - Fan case "1"
 - Fan "2"Damage → Replace.
Dirt/clog → Clean.

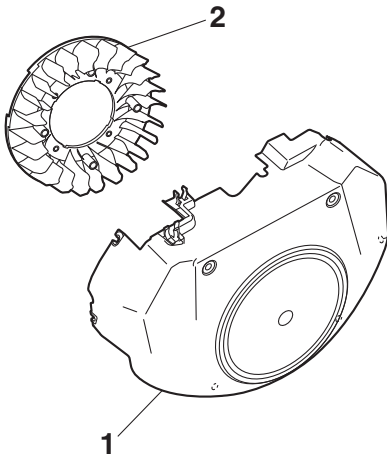

CASE AND FAN

INSTALLING THE CASE AND FAN

1. Install:
 - Fan "1"
 - Fan bolt

	Fan bolt: 4.5 N·m (0.45 kgf·m, 3.3 lb·ft)
---	--

2. Install:
 - Fan case "2"
 - Fan case bolt (side)
 - Fan case bolt (front)

	Fan case bolt (side): 2.5 N·m (0.25 kgf·m, 1.8 lb·ft)
	Fan case bolt (front): 4.5 N·m (0.45 kgf·m, 3.3 lb·ft)

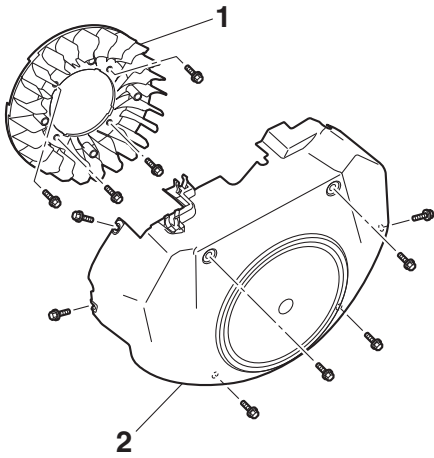

ENGINE 3

CYLINDER COVERS

CYLINDER COVERS

CYLINDER COVER 1 AND CYLINDER COVER 2

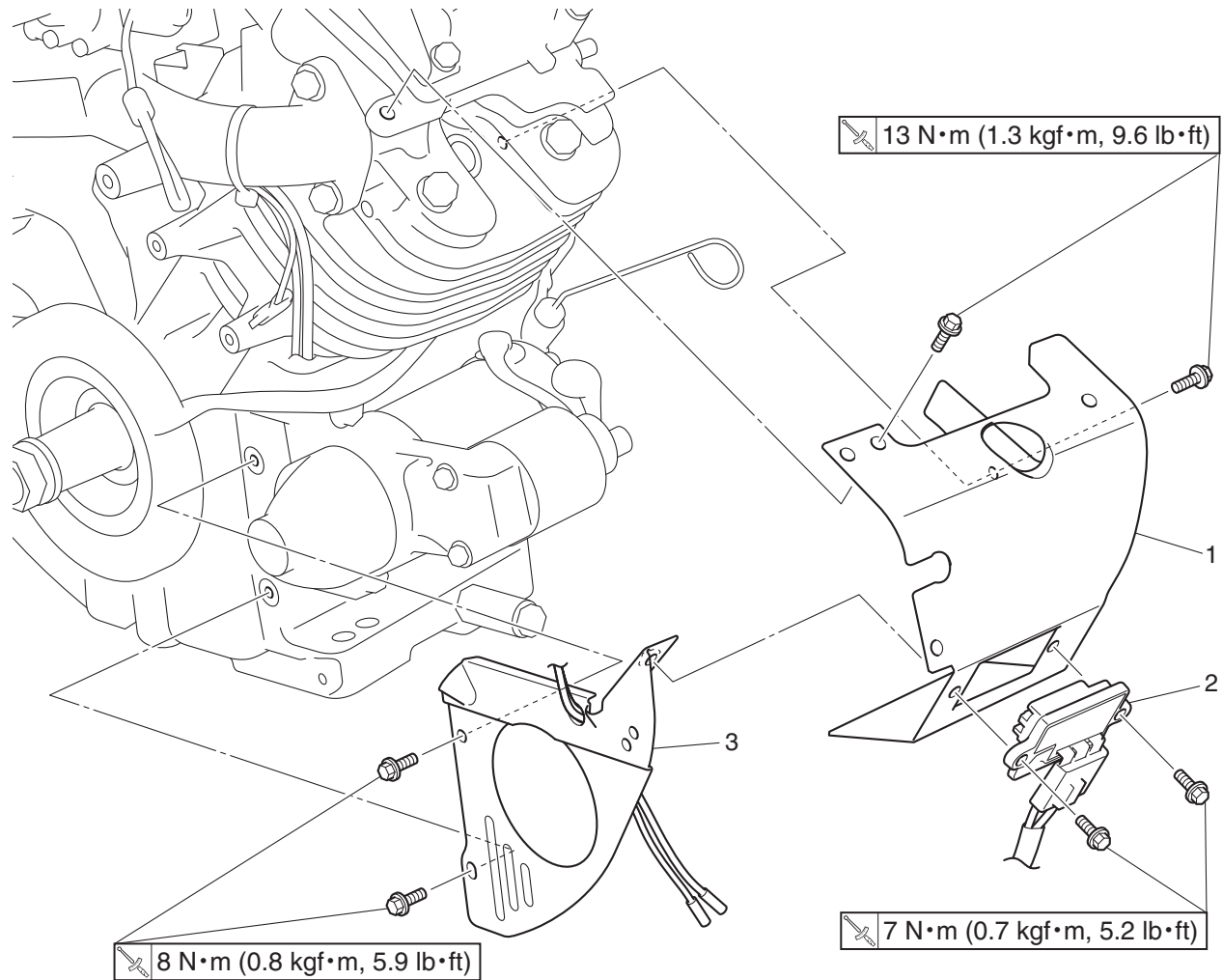

3
ENGINE

Order	Job/Parts to remove	Q'ty	Remarks
	Removing the cylinder covers		Remove the parts in the order listed.
	Muffler		Refer to "MUFFLER" on page 3-5.
	Air filter		Refer to "AIR FILTER" on page 3-3.
	Fan case		Refer to "CASE AND FAN" on page 3-14.
1	Cylinder cover 1	1	
2	Rectifier/regulator	1	
3	Cylinder cover 2	1	

CYLINDER COVERS

CYLINDER COVER 3

ENGINE
3

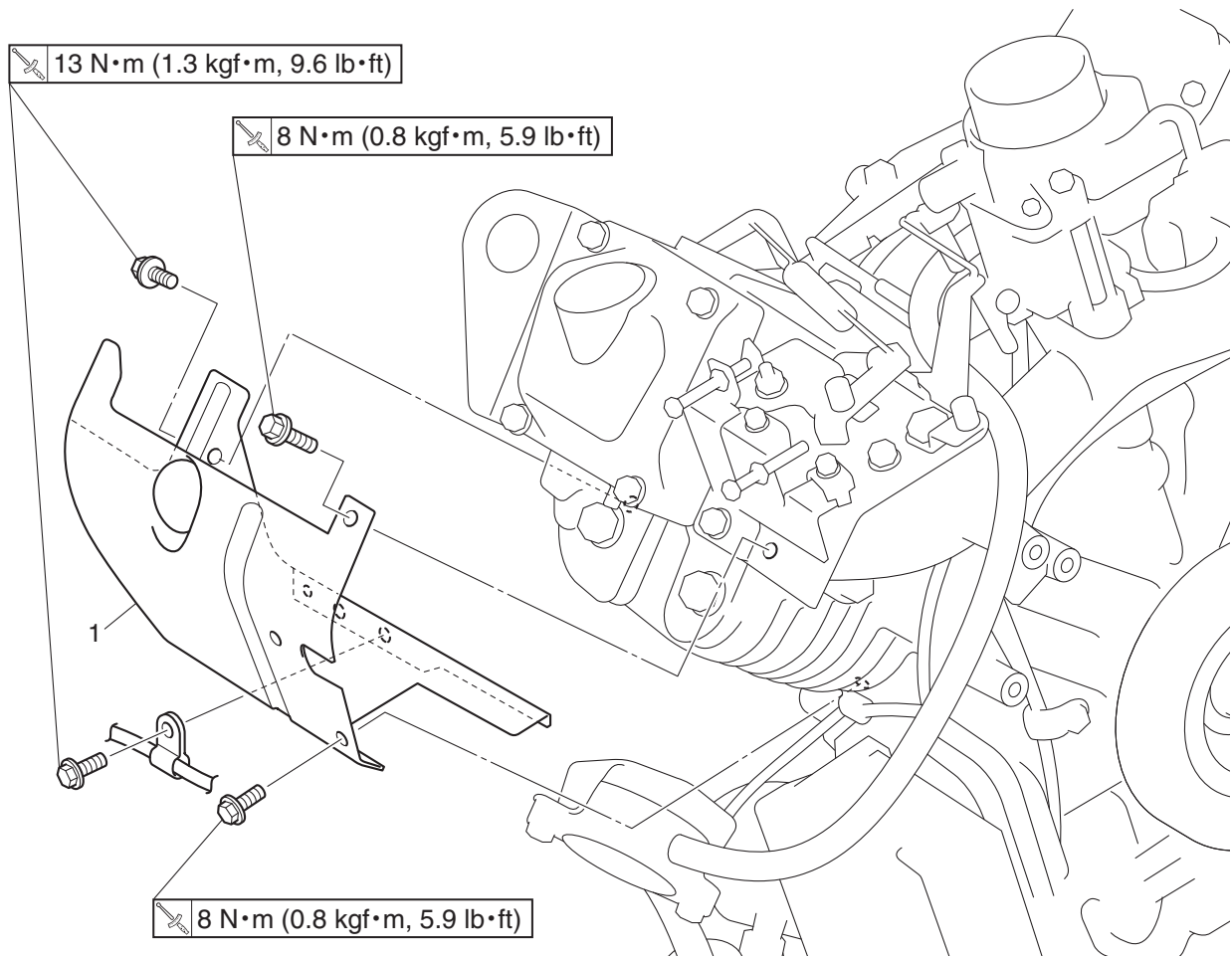

Order	Job/Parts to remove	Q'ty	Remarks
	Removing the cylinder cover		Remove the parts in the order listed.
	Muffler		Refer to "MUFFLER" on page 3-5.
	Air filter		Refer to "AIR FILTER" on page 3-3.
	Fan case		Refer to "CASE AND FAN" on page 3-14.
	Fuel pump		Refer to "FUEL PUMP" on page 4-1.
1	Cylinder cover 3	1	

TCI UNITS, FLYWHEEL AND STATOR COIL ASSEMBLY

TCI UNITS, FLYWHEEL AND STATOR COIL ASSEMBLY

TCI UNITS

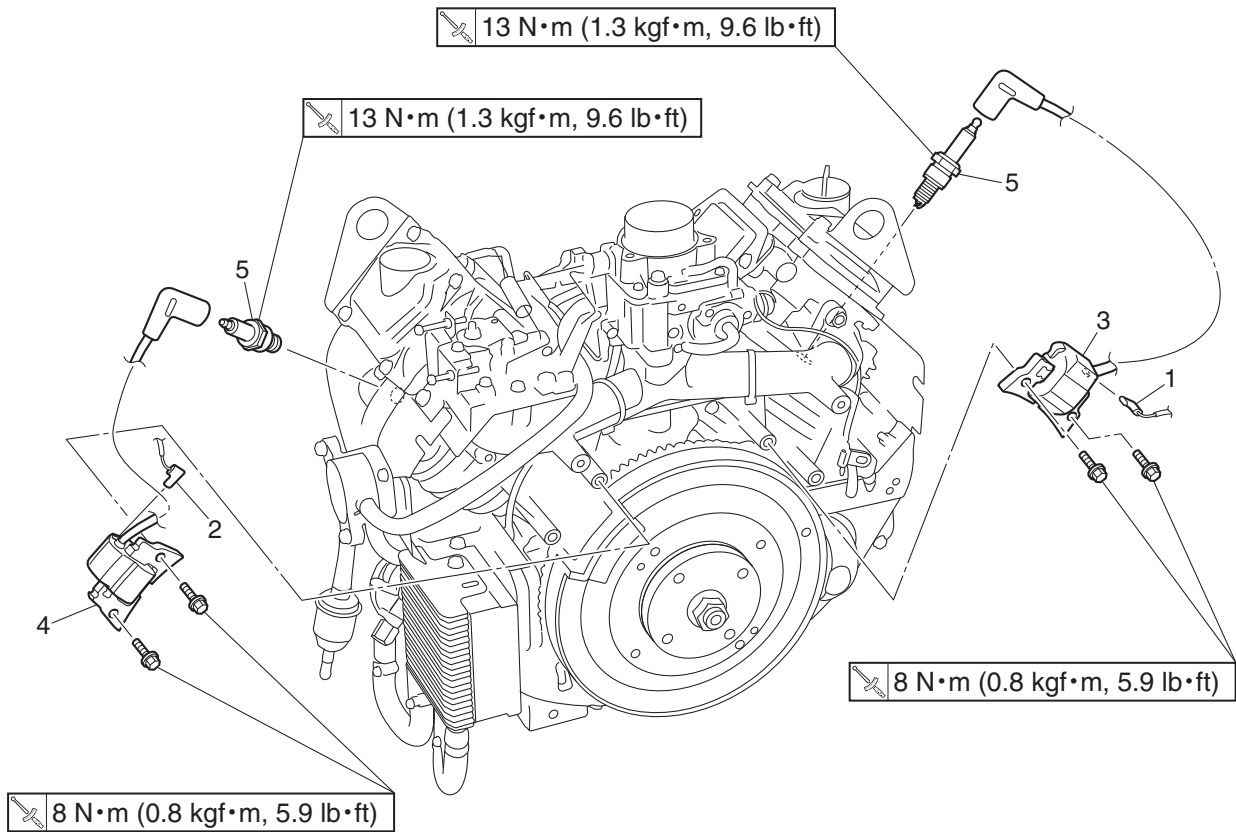

3
ENGINE

Order	Job/Parts to remove	Q'ty	Remarks
	Removing the TCI unit		Remove the parts in the order listed.
	Muffler		Refer to "MUFFLER" on page 3-5.
	Air filter		Refer to "AIR FILTER" on page 3-3.
	Fan case		Refer to "CASE AND FAN" on page 3-14.
1	TCI unit #1 lead connector	1	Disconnect.
2	TCI unit #2 lead connector	1	Disconnect.
3	TCI unit #1	1	
4	TCI unit #2	1	
5	Spark plug	2	

TCI UNITS, FLYWHEEL AND STATOR COIL ASSEMBLY

FLYWHEEL AND STATOR COIL ASSEMBLY

ENGINE 3

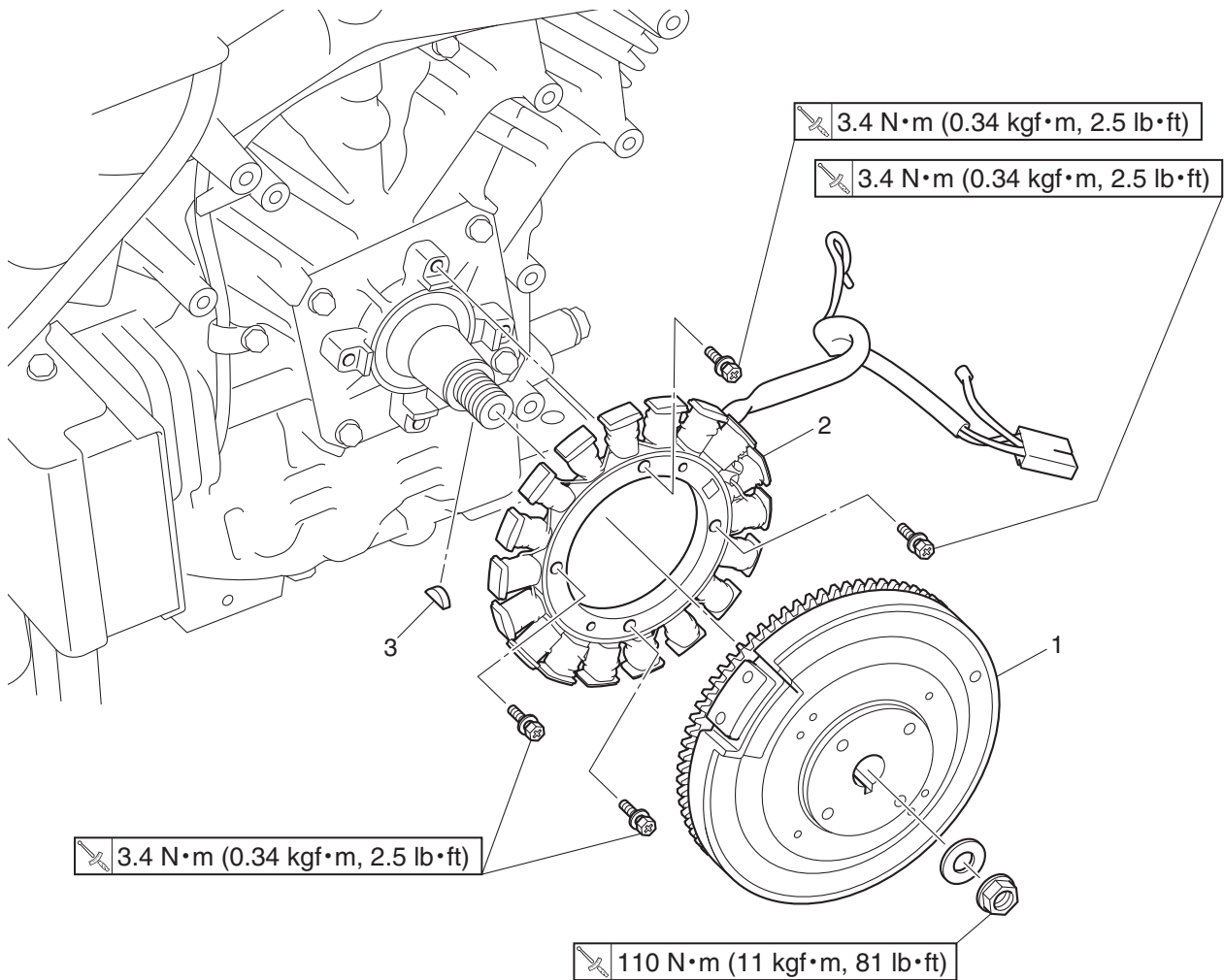

Order	Job/Parts to remove	Q'ty	Remarks
	Removing the flywheel and stator coil assembly		Remove the parts in the order listed.
	Air filter		Refer to "AIR FILTER" on page 3-3.
	Fan case and fan		Refer to "CASE AND FAN" on page 3-14.
	Rectifier/regulator		Refer to "RECTIFIER/REGULATOR" on page 3-13.
	Cylinder cover		Refer to "CYLINDER COVERS" on page 3-17.
	TCI unit		Refer to "TCI UNITS" on page 3-19.
1	Flywheel	1	
2	Stator coil assembly	1	
3	Woodruff key	1	

REMOVING THE FLYWHEEL AND STATOR COIL ASSEMBLY

1. Remove:
 - Air filter
(Refer to "AIR FILTER" on page 3-3.)
2. Remove:
 - Fan case and fan
(Refer to "CASE AND FAN" on page 3-14.)
3. Remove:
 - Rectifier/regulator
(Refer to "RECTIFIER/REGULATOR" on page 3-13.)
4. Remove:
 - Cylinder covers
(Refer to "CYLINDER COVERS" on page 3-17.)
5. Remove:
 - TCI units "1"

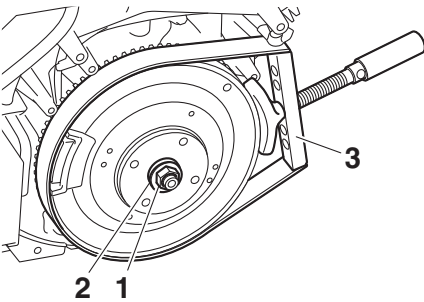
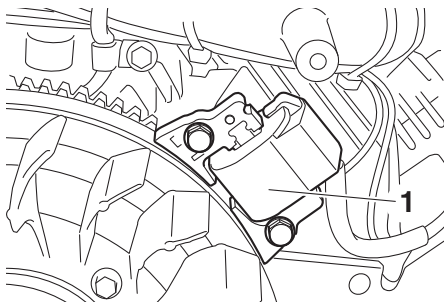

6. Remove:
 - Flywheel nut "1"
 - Washer "2"

TIP _____
Attach the sheave holder "3" to hold the flywheel.



Sheave holder:
90890-01701

Primary clutch holder:
YS-01880-A

7. Remove:
 - Flywheel "1"
 - Woodruff key

TIP _____
• Remove the flywheel "1" using the flywheel puller "2".
• Fully tighten the tool holding bolts, making sure the tool body is parallel with the flywheel. If necessary, one bolt may be backed out slightly to level the tool body.

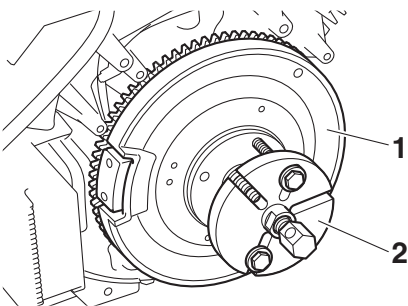

TCI UNITS, FLYWHEEL AND STATOR COIL ASSEMBLY



Flywheel puller:
90890-01362
Heavy duty puller:
YU-33270-B

- 8.** Remove:
- Stator coil assembly

CHECKING THE FLYWHEEL AND STATOR COIL ASSEMBLY

- 1.** Check:
- Flywheel “1”
 - Stator coil assembly “2”
- Damage → Replace.

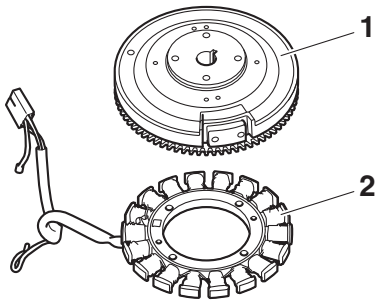

INSTALLING THE FLYWHEEL AND STATOR COIL ASSEMBLY

- 1.** Install:
- Stator coil assembly
 - Stator coil assembly bolt



Stator coil assembly bolt:
3.4 N·m (0.34 kgf·m, 2.5 lb·ft)

TIP

Install the lead “a” of the stator coil assembly so that it is at about the 2 o’clock position, as shown in the illustration.

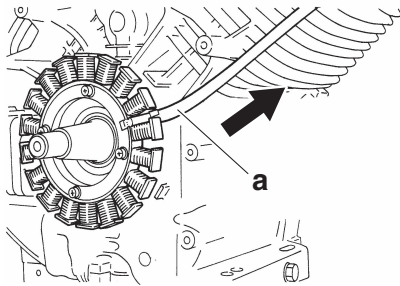

- 2.** Install:
- Flywheel
- 3.** Install:
- Washer “1”
 - Flywheel nut “2”



Flywheel nut:
110 N·m (11 kgf·m, 81 lb·ft)

TIP

Attach the sheave holder “3” to hold the flywheel.

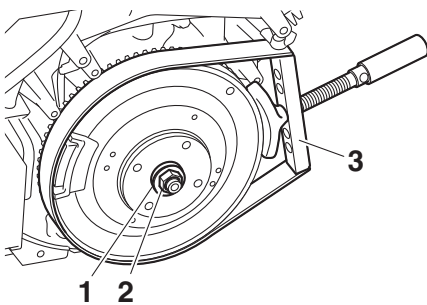

TCI UNITS, FLYWHEEL AND STATOR COIL ASSEMBLY



Sheave holder:
90890-01701
Primary clutch holder:
YS-01880-A

- 4.** Install:
- TCI unit
 - TCI unit bolt
- (Refer to “INSTALLING THE TCI UNITS” on page 3-23.)



TCI unit bolt:
8 N·m (0.8 kgf·m, 5.9 lb·ft)

- 5.** Install:
- Cylinder covers
- (Refer to “CYLINDER COVERS” on page 3-17.)
- 6.** Install:
- Rectifier/regulator
- (Refer to “RECTIFIER/REGULATOR” on page 3-13.)
- 7.** Install:
- Fan case and fan
- (Refer to “INSTALLING THE CASE AND FAN” on page 3-16.)
- 8.** Install:
- Air filter
- (Refer to “AIR FILTER” on page 3-3.)
- 9.** Install:
- Muffler
- (Refer to “INSTALLING THE MUFFLER” on page 3-9.)

INSTALLING THE TCI UNITS

The following procedure applies to all of the TCI units.

- 1.** Install:
- TCI unit
 - TCI unit bolt



TCI unit bolt:
8 N·m (0.8 kgf·m, 5.9 lb·ft)

TCI UNITS, FLYWHEEL AND STATOR COIL ASSEMBLY

ENGINE 3

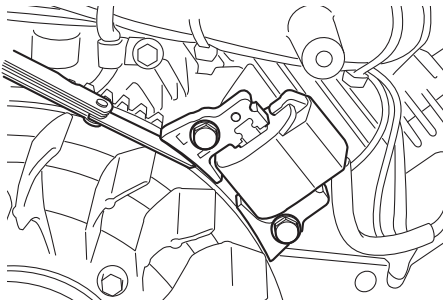



- 2.** Measure:
- TCI unit air gap
Out of specification → Adjust.

	Thickness gauge: 90890-03268 Feeler gauge set: YU-26900-9
---	--

	TCI unit air gap: 0.3–0.5 mm (0.011–0.019 in)
---	--

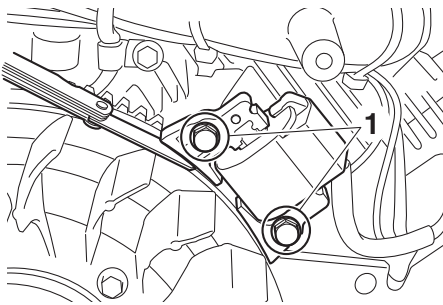
- 3.** Adjust:
- TCI unit air gap
- Adjustment steps:**
- Loosen the TCI unit bolts “1”.
 - Adjust the TCI unit air gap.



	Thickness gauge: 90890-03268 Feeler gauge set: YU-26900-9
--	--

- Tighten the TCI unit bolts “1”.

	TCI unit bolt: 8 N·m (0.8 kgf·m, 5.9 lb·ft)
---	--

ENGINE SWITCH AND OIL WARNING LIGHT (EQUIPPED MODELS ONLY)

ENGINE SWITCH AND OIL WARNING LIGHT (EQUIPPED MODELS ONLY)

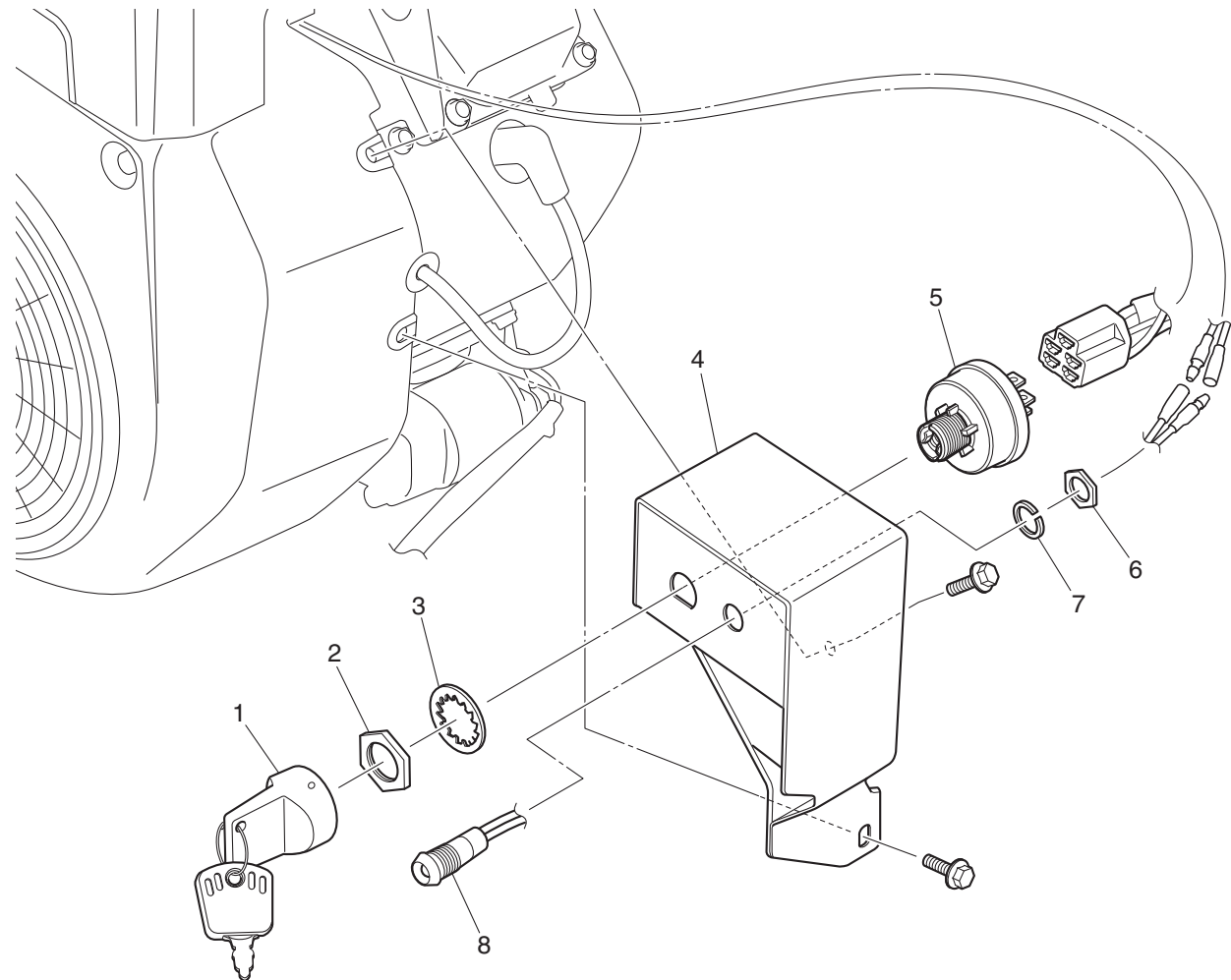

3

ENGINE

Order	Job/Parts to remove	Q'ty	Remarks
	Removing the engine switch and oil warning light		Remove the parts in the order listed.
1	Key	1	
2	Nut	1	
3	Washer	1	
4	Engine switch cover	1	
5	Engine switch	1	
6	Nut	1	
7	Spring washer	1	
8	Oil warning light	1	

CYLINDER HEAD COVERS, CYLINDER HEADS

CYLINDER HEAD COVERS, CYLINDER HEADS

CYLINDER HEAD #1

3

ENGINE

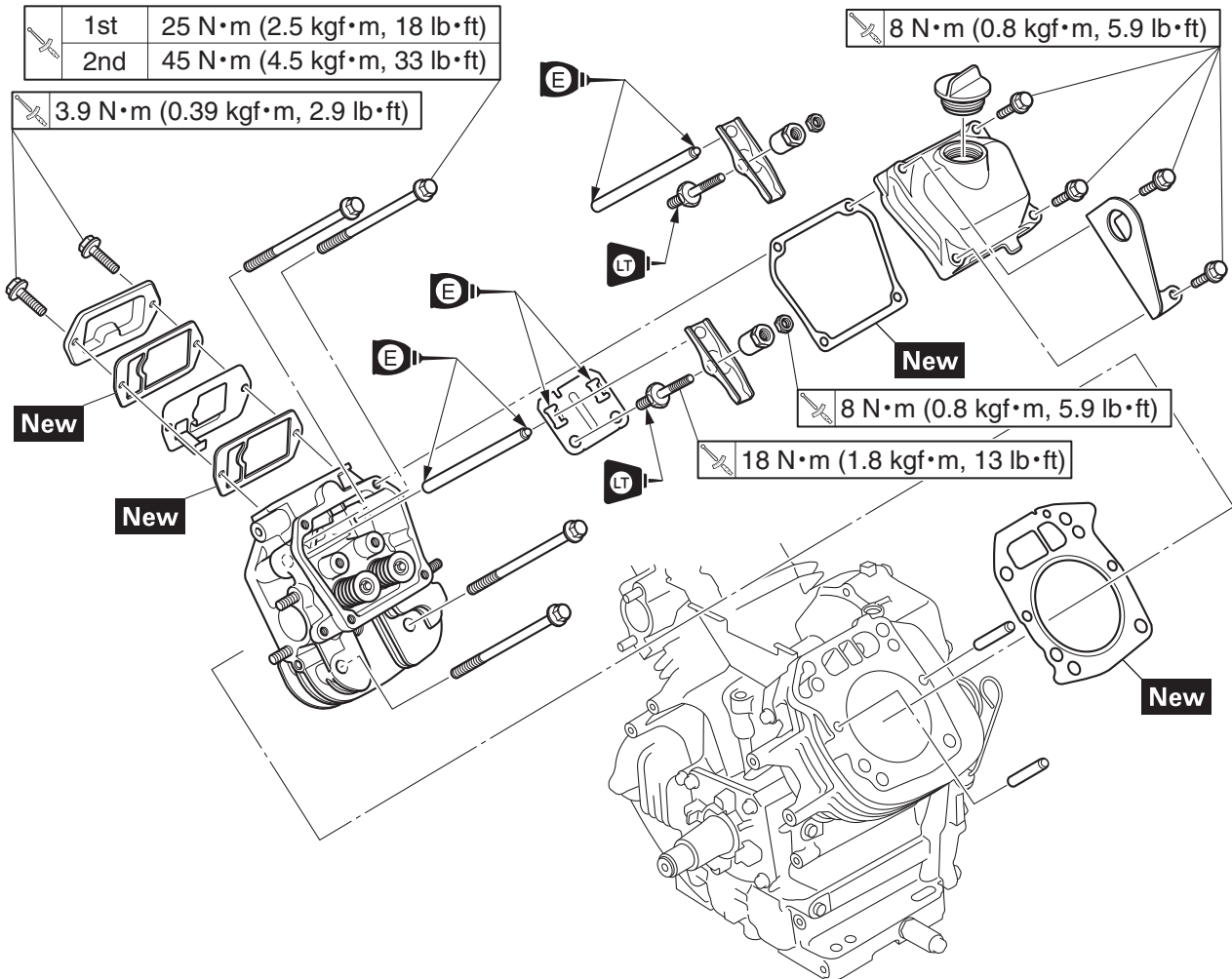

Order	Job/Parts to remove	Q'ty	Remarks
	Removing the cylinder head cover and cylinder head		Remove the parts in the order listed.
	Muffler		Refer to "MUFFLER" on page 3-5.
	Air filter		Refer to "AIR FILTER" on page 3-3.
	Fan case and fan		Refer to "CASE AND FAN" on page 3-14.
	Rectifier/regulator		Refer to "RECTIFIER/REGULATOR" on page 3-13.
	Fuel pump		Refer to "FUEL PUMP" on page 4-1.
	Cylinder cover		Refer to "CYLINDER COVERS" on page 3-17.
	TCI unit		Refer to "TCI UNITS" on page 3-19.
	Carburetor		Refer to "CARBURETOR ASSEMBLY" on page 4-4.
	Intake manifold		Refer to "INTAKE MANIFOLD" on page 4-14.
	Starter motor assembly		Refer to "REMOVING THE STARTER MOTOR" on page 5-10.

CYLINDER HEAD COVERS, CYLINDER HEADS

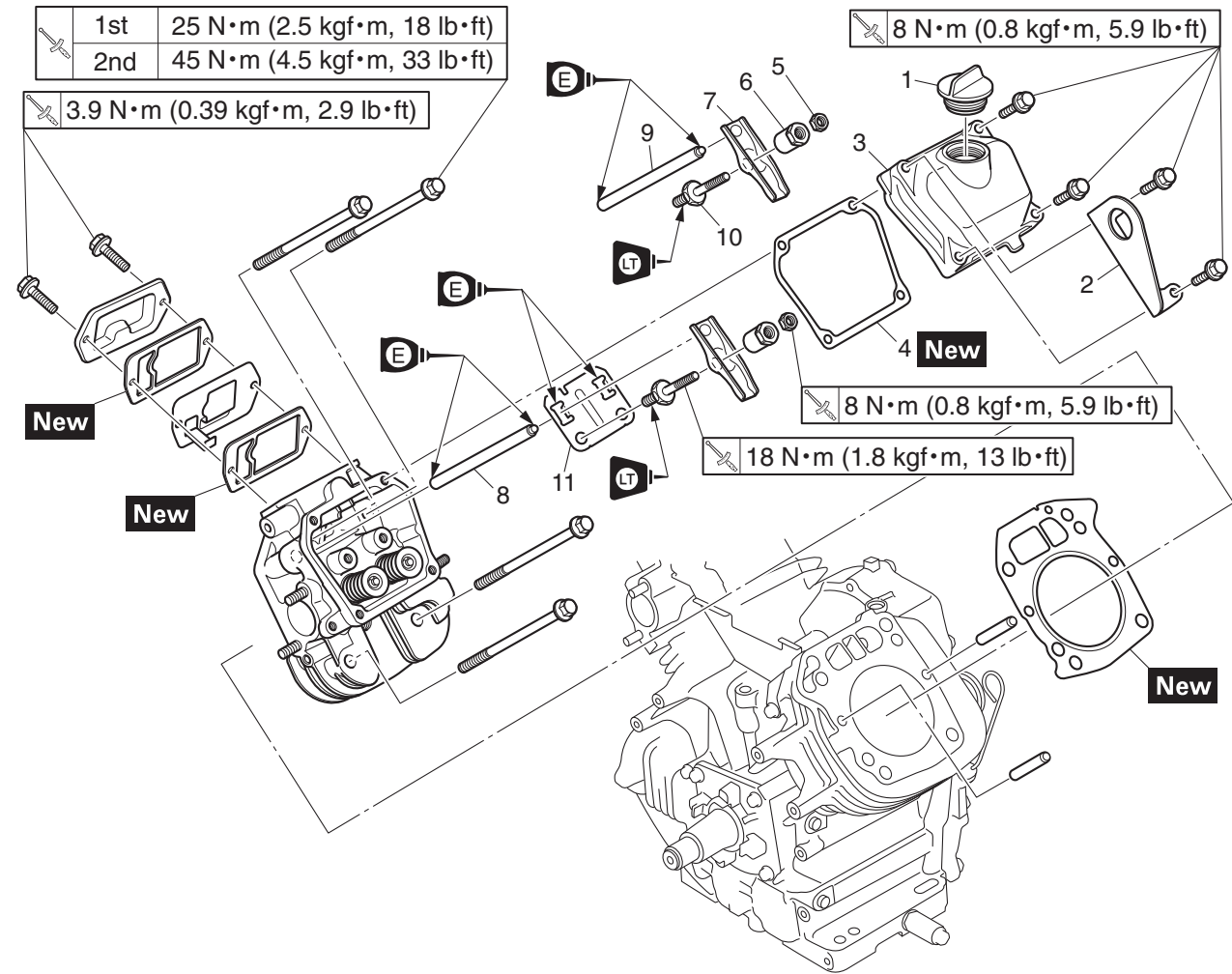

3
ENGINE

Order	Job/Parts to remove	Q'ty	Remarks
1	Oil filler cap	1	
2	Engine hanger	1	
3	Cylinder head cover	1	
4	Gasket	1	
5	Locknut	2	
6	Adjuster	2	
7	Rocker arm	2	
8	Push rod	1	Intake side
9	Push rod	1	Exhaust side
10	Pivot bolt	2	
11	Push rod guide	1	

CYLINDER HEAD COVERS, CYLINDER HEADS

ENGINE

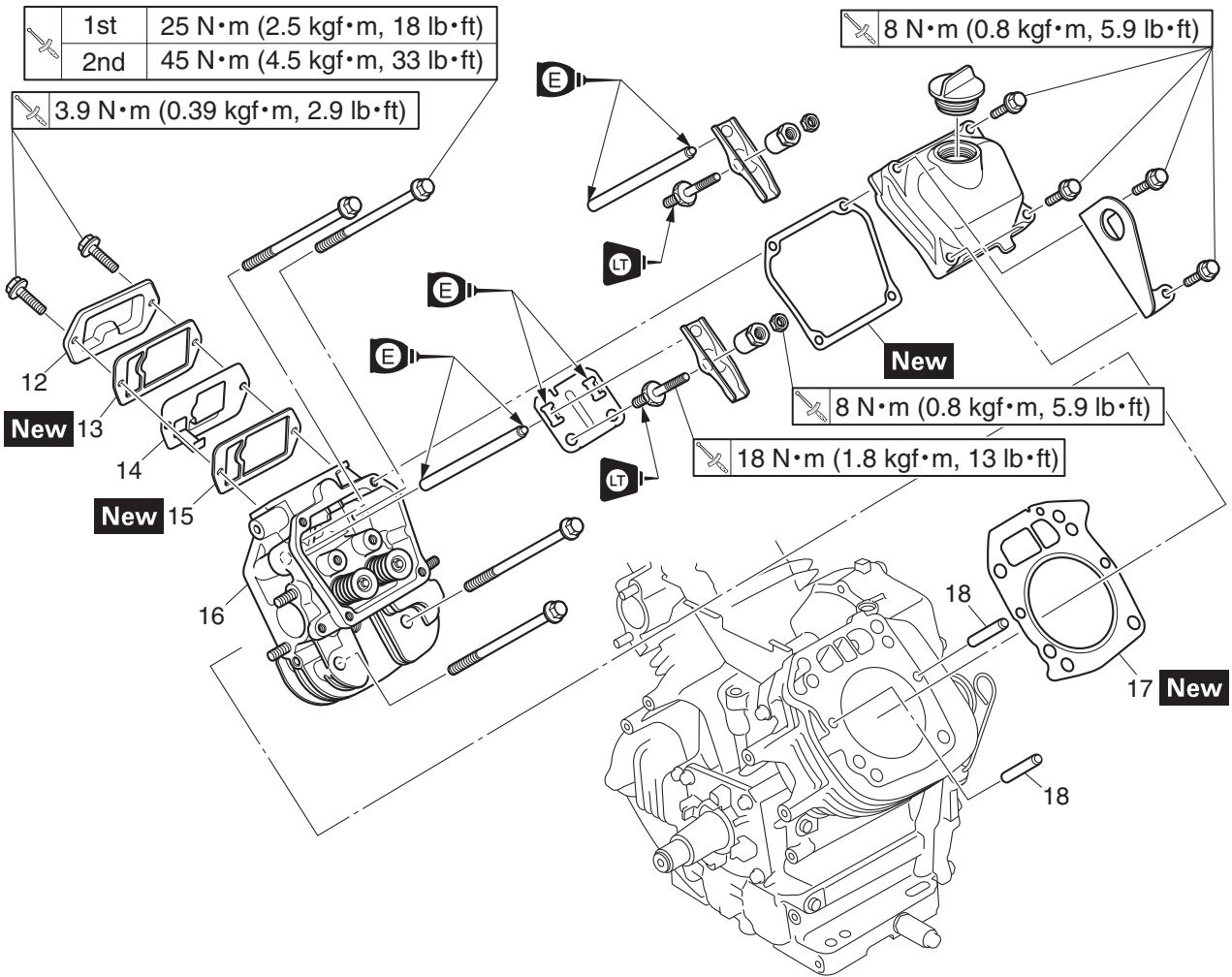

Order	Job/Parts to remove	Q'ty	Remarks
12	Breather cover	1	
13	Gasket	1	
14	Breather assembly	1	
15	Gasket	1	
16	Cylinder head assembly #1	1	
17	Gasket	1	
18	Dowel pin	2	

CYLINDER HEAD COVERS, CYLINDER HEADS

CYLINDER HEAD #2

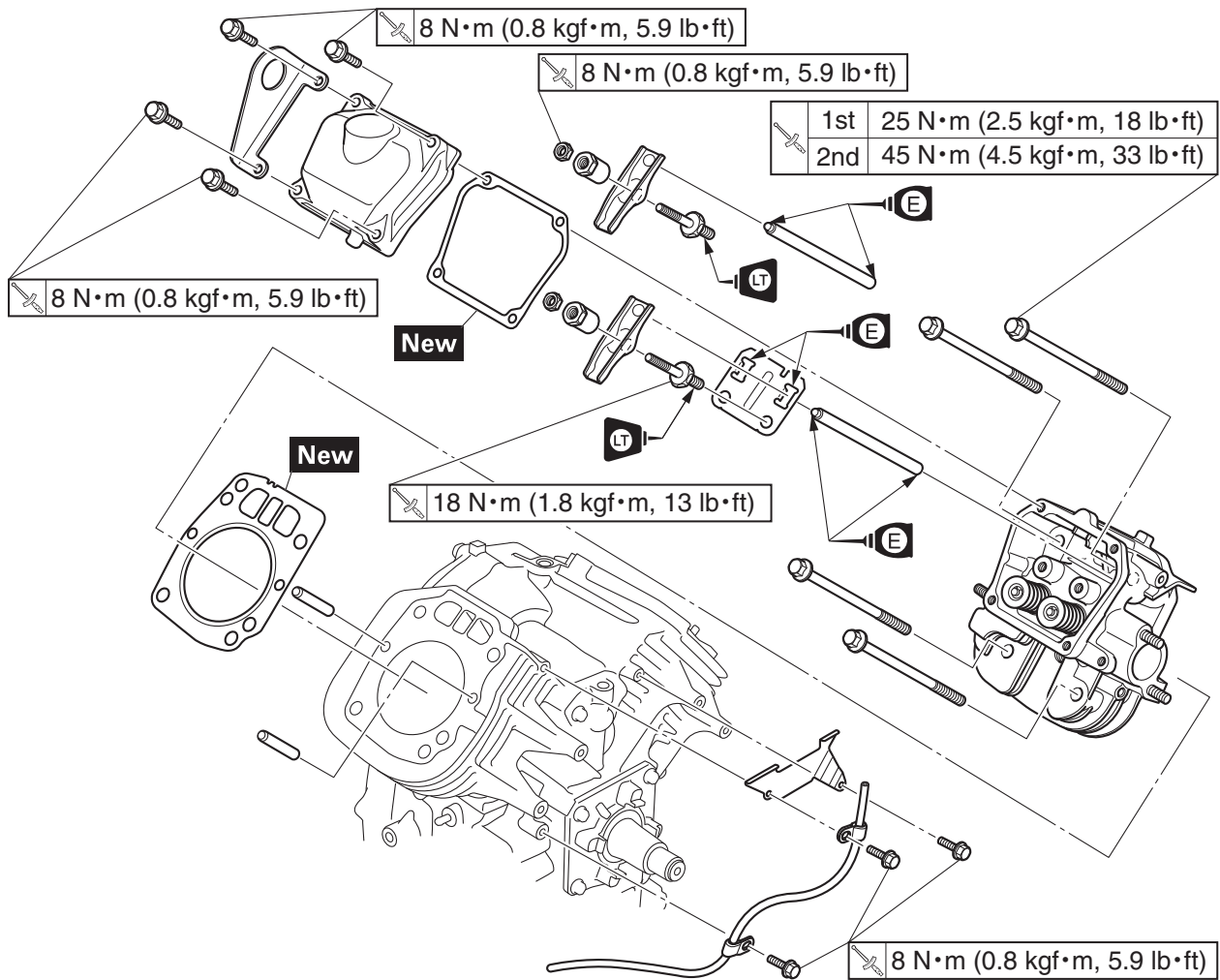

3

ENGINE

Order	Job/Parts to remove	Q'ty	Remarks
	Removing the cylinder head cover and cylinder head		Remove the parts in the order listed.
	Muffler		Refer to "MUFFLER" on page 3-5.
	Air filter		Refer to "AIR FILTER" on page 3-3.
	Fan case and fan		Refer to "CASE AND FAN" on page 3-14.
	Rectifier/regulator		Refer to "RECTIFIER/REGULATOR" on page 3-13.
	Fuel pump		Refer to "FUEL PUMP" on page 4-1.
	Cylinder cover		Refer to "CYLINDER COVERS" on page 3-17.
	TCI unit		Refer to "TCI UNITS" on page 3-19.
	Carburetor		Refer to "CARBURETOR ASSEMBLY" on page 4-4.
	Intake manifold		Refer to "INTAKE MANIFOLD" on page 4-14.
	Starter motor assembly		Refer to "REMOVING THE STARTER MOTOR" on page 5-10.

CYLINDER HEAD COVERS, CYLINDER HEADS

ENGINE 3

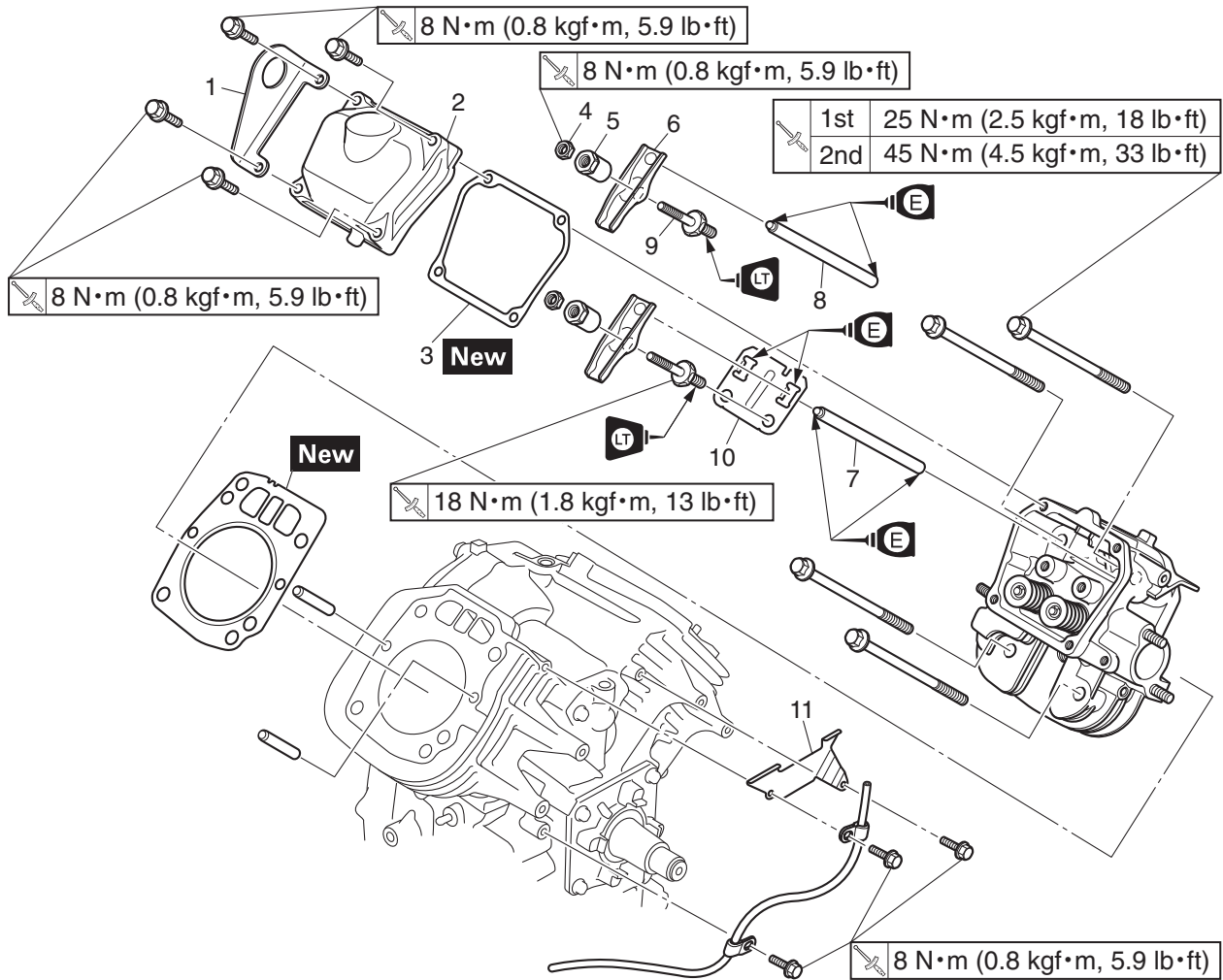

Order	Job/Parts to remove	Q'ty	Remarks
1	Engine hanger	1	
2	Cylinder head cover	1	
3	Gasket	1	
4	Locknut	2	
5	Adjuster	2	
6	Rocker arm	2	
7	Push rod	1	Intake side
8	Push rod	1	Exhaust side
9	Pivot bolt	2	
10	Push rod guide	1	
11	Bracket	1	EH64A/EH64K/EH65A/EH65B only

CYLINDER HEAD COVERS, CYLINDER HEADS

3
ENGINE

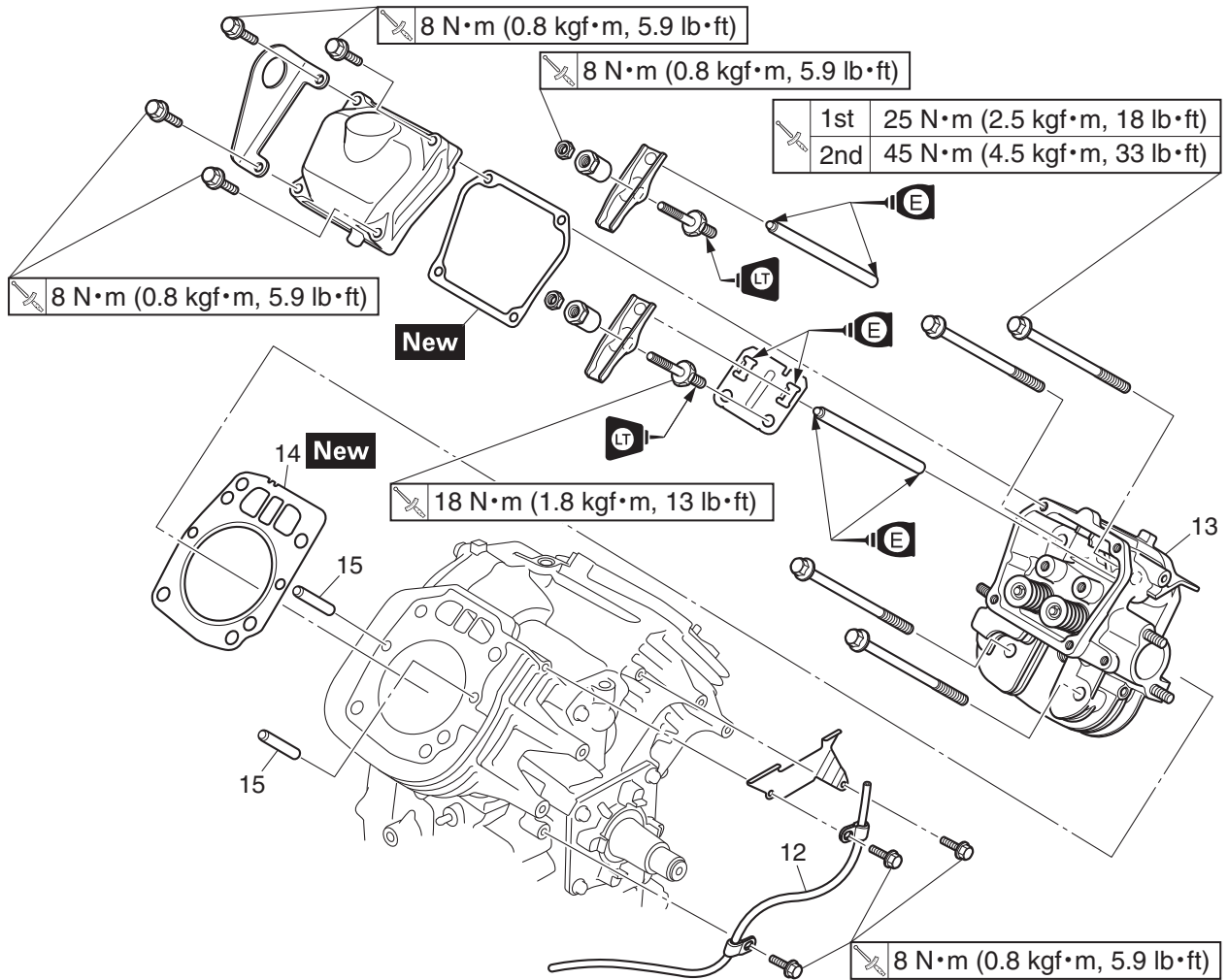

Order	Job/Parts to remove	Q'ty	Remarks
12	Carburetor breather hose	1	From carburetor
13	Cylinder head assembly #2	1	
14	Gasket	1	
15	Dowel pin	2	

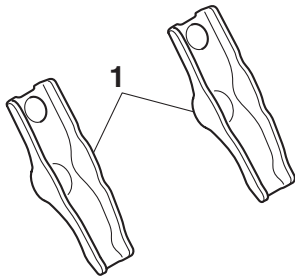

CHECKING THE ROCKER ARMS

1. Check:
 - Rocker arm "1"
Wear/damage/cracks → Replace.

REMOVING THE CYLINDER HEADS

The following procedure applies to all of the cylinder heads.

1. Remove:
 - Cylinder head

TIP

Set the piston at TDC (top-dead-center) on the compression stroke.
(Refer to "ADJUSTING THE VALVE CLEARANCE" on page 2-13.)

CHECKING THE CYLINDER HEADS

The following procedure applies to all of the cylinder heads.

1. Check:
 - Cylinder head combustion chamber
Check the combustion chamber for carbon deposits.
Carbon deposits → Eliminate.

TIP

Be sure not to damage the contact surface of the cylinder.

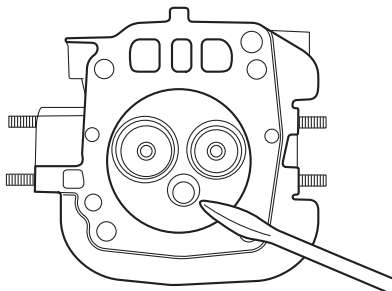

2. Check:
 - Cylinder head
Cracks/damage around the hole of spark plug → Replace.
3. Measure:
 - Cylinder head warpage

TIP

Measure the warpage on the contact surface of the cylinder head at six points using the straight edge and thickness gauge.

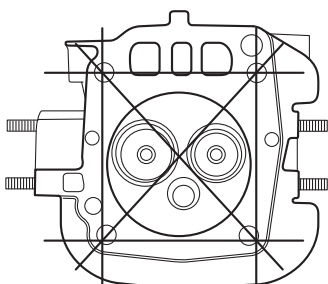

CYLINDER HEAD COVERS, CYLINDER HEADS



Warpage limit:
0.1 mm (0.0039 in)

Out of specifications → Resurface or replace.

INSTALLING THE CYLINDER HEAD ASSEMBLIES

- 1.** Install:
- Cylinder head assembly #1
 - Cylinder head bolt “1”–“4”

TIP

Tighten the bolts to the specified torque in two steps and in order from “1”–“4”.

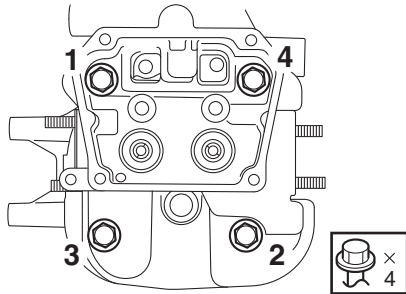

Cylinder head bolt:
1st: 25 N·m (2.5 kgf·m, 18 lb·ft)
2nd: 45 N·m (4.5 kgf·m, 33 lb·ft)

- 2.** Install:
- Cylinder head assembly #2
 - Cylinder head bolt “1”–“4”

TIP

Tighten the bolts to the specified torque in two steps and in order from “1”–“4”.

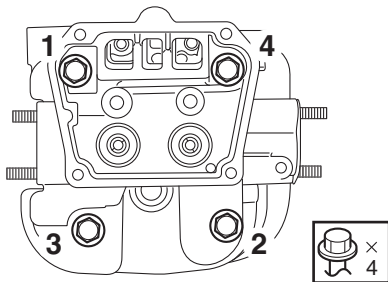

Cylinder head bolt:
1st: 25 N·m (2.5 kgf·m, 18 lb·ft)
2nd: 45 N·m (4.5 kgf·m, 33 lb·ft)

VALVES

VALVES

CYLINDER HEAD #1

3
ENGINE

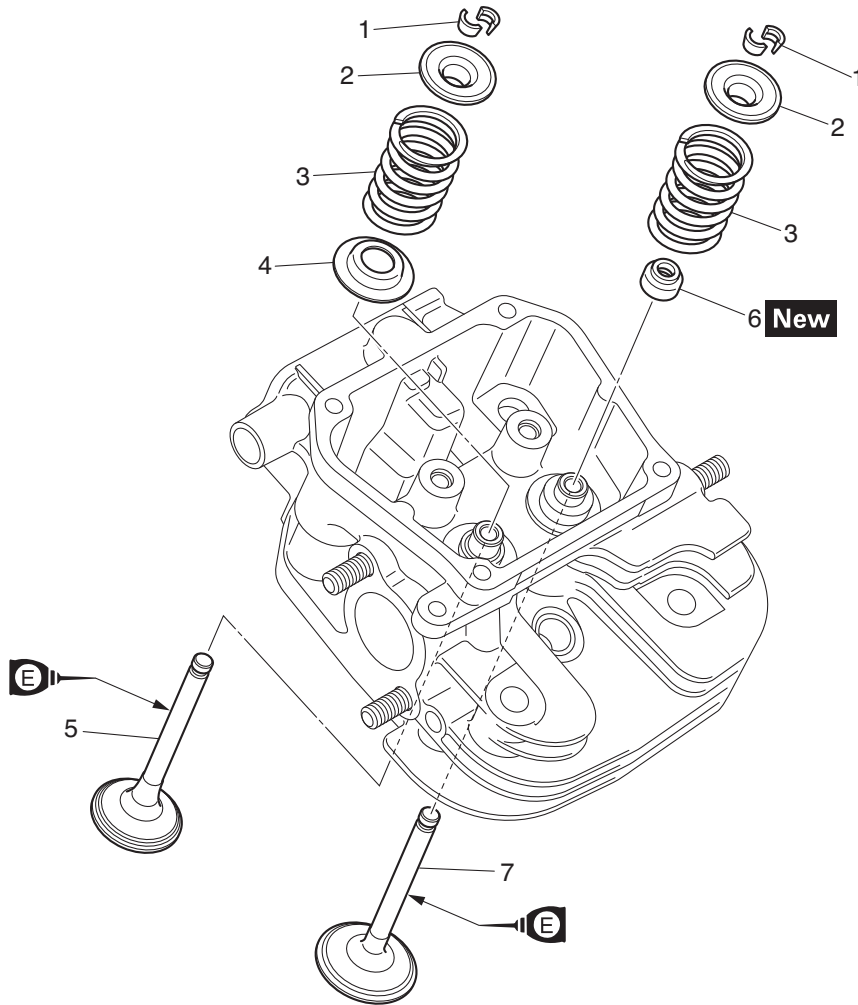

Order	Job/Parts to remove	Q'ty	Remarks
	Removing the valves		Remove the parts in the order listed.
	Cylinder head assembly		Refer to "CYLINDER HEAD COVERS, CYLINDER HEADS" on page 3-26.
1	Valve cotter	4	
2	Valve spring retainer	2	
3	Valve spring	2	
4	Valve spring seat	1	Exhaust side only
5	Exhaust valve	1	
6	Valve stem seal	1	Intake side only
7	Intake valve	1	

VALVES

CYLINDER HEAD #2

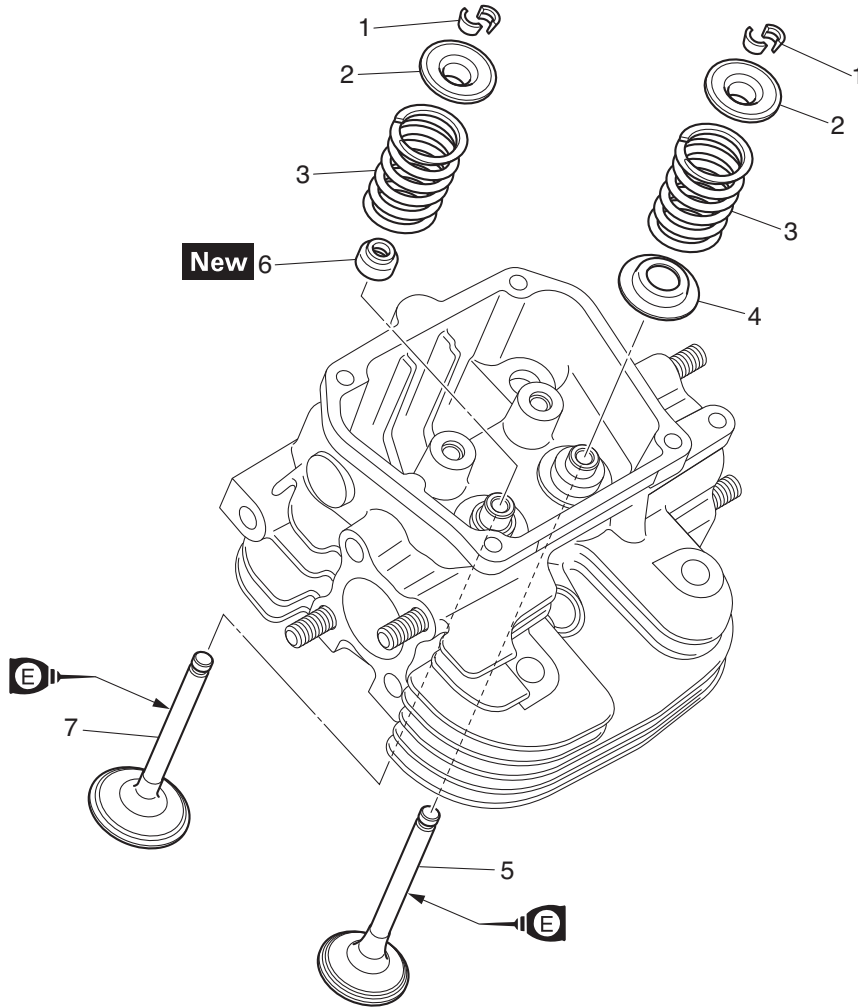

Order	Job/Parts to remove	Q'ty	Remarks
	Removing the valves		Remove the parts in the order listed.
	Cylinder head assembly		Refer to "CYLINDER HEAD COVERS, CYLINDER HEADS" on page 3-26.
1	Valve cotter	4	
2	Valve spring retainer	2	
3	Valve spring	2	
4	Valve spring seat	1	Exhaust side only
5	Exhaust valve	1	
6	Valve stem seal	1	Intake side only
7	Intake valve	1	

VALVES

ENGINE 3

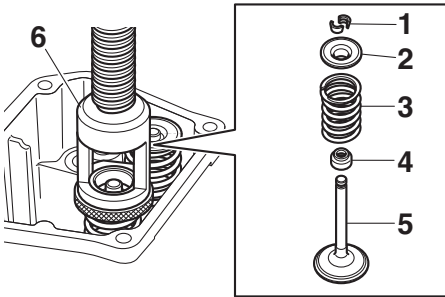

REMOVING THE VALVES AND VALVE SPRINGS

The following procedure applies to all of the valves, valve springs and related components.

1. Remove the parts below from the intake side.
 - Valve cotter "1"
 - Valve spring retainer "2"
 - Valve spring "3"
 - Valve stem seal "4"
 - Intake valve "5"Remove the parts using the valve spring compressor "6".

NOTICE

Do not compress the valve spring more than necessary.



Valve spring compressor:
90890-01253

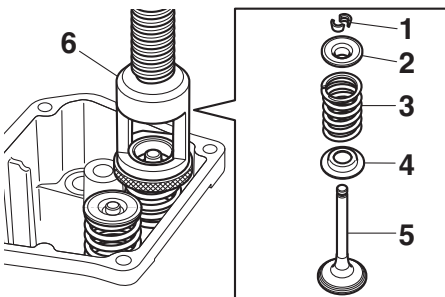

2. Remove the parts below from the exhaust side.
 - Valve cotter "1"
 - Valve spring retainer "2"
 - Valve spring "3"
 - Valve spring seat "4"
 - Exhaust valve "5"Remove the parts using the valve spring compressor "6".

NOTICE

Do not compress the valve spring more than necessary.



Valve spring compressor:
90890-01253

CHECKING THE VALVES AND VALVE SPRINGS

The following procedure applies to all of the valve and valve springs.

1. Measure:
 - Valve stem length "a"
 - Valve head diameter "b"

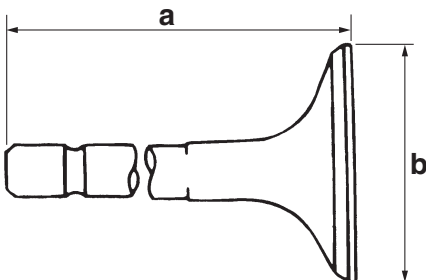



Valve stem length (Intake):
79.8 mm (3.1417 in)
Valve stem length (Exhaust):
80.3 mm (3.1614 in)
Valve head diameter (Intake):
34.99–35.01 mm (1.3775–1.3783 in)
Valve head diameter (Exhaust):
30.9–31.1 mm (1.2165–1.2244 in)

Out of specifications → Replace.

- 2.** Measure:
- Valve stem diameter “a”

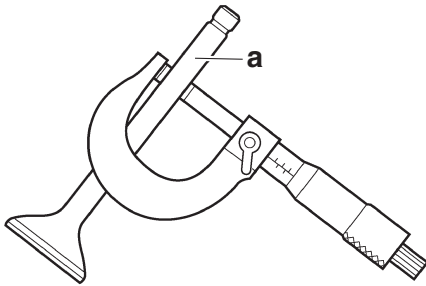

Valve stem diameter (Intake):
5.970–5.985 mm (0.2350–0.2356 in)
Valve stem diameter (Exhaust):
5.970–5.985 mm (0.2350–0.2356 in)
Limit (Intake):
5.940 mm (0.2338 in)
Limit (Exhaust):
5.940 mm (0.2338 in)

Out of specifications → Replace.

- 3.** Measure:
- Valve stem runout

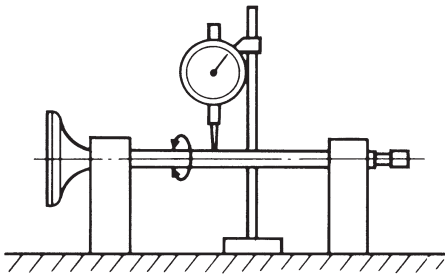

Valve stem runout limit:
0.01 mm (0.0004 in)

Out of specifications → Replace.

TIP _____
The value is half of that indicated on the dial indicator gauge.

- 4.** Measure:
- Valve spring free length “a”

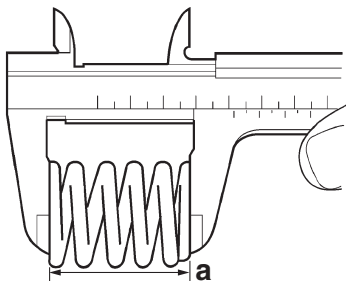

Valve spring free length (Intake):
36.5 mm (1.4370 in)
Valve spring free length (Exhaust):
36.5 mm (1.4370 in)
Limit (Intake):
34.67 mm (1.3649 in)
Limit (Exhaust):
34.67 mm (1.3649 in)

Out of specifications → Replace.

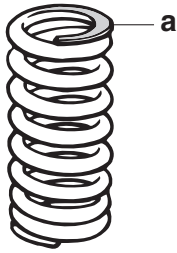

5. Check:

- Valve spring contact surface “a”
More than 2/3 of the contact surface does not contact → Replace.

CHECKING THE VALVE SEATS

The following procedure applies to all of the valves and valve seats.

- 1.** Remove carbon deposits from the valve face and valve seat.
- 2.** Apply a small amount of coarse mechanic’s blue layout fluid to the valve face “a”.

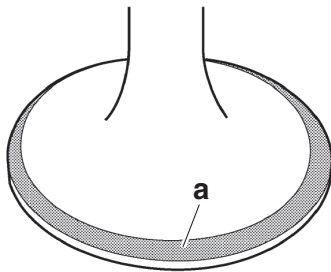

- 3.** Insert the valve into the valve guide and use a valve lapper to contact the valve face with the valve seat.

TIP

Do not rotate the valve while the valve face is contacting the valve seat.

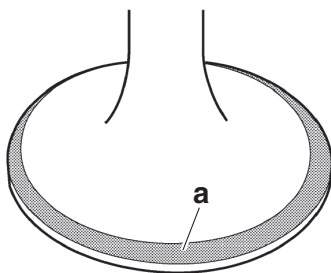

4. Measure:

- Valve face contact width “a”
Make sure that the contact width along the entire valve face is within specifications.

	Valve face contact width (Intake):
	0.7–1.0 mm (0.0275–0.0393 in)
	Valve face contact width (Exhaust):
	0.7–1.0 mm (0.0275–0.0393 in)
	Limit (Intake):
2.0 mm (0.0787 in)	
Limit (Exhaust):	
2.0 mm (0.0787 in)	

Out of specification/rough/eccentric wear → Replace.

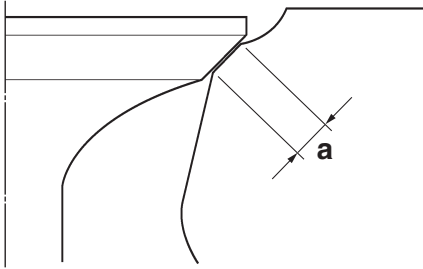

5. Measure:

- Valve seat contact width “a”
Make sure that the contact width along the entire valve seat is within specifications.

	Valve seat contact width (Intake): 0.7–1.0 mm (0.0275–0.0393 in)
	Valve seat contact width (Exhaust): 0.7–1.0 mm (0.0275–0.0393 in)
	Limit (Intake): 2.0 mm (0.0787 in)
	Limit (Exhaust): 2.0 mm (0.0787 in)

Out of specification/rough/eccentric wear → Replace.

VALVE LAPPING

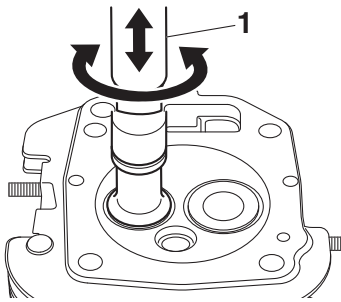

- 1.** Apply a coarse lapping compound evenly on the valve face. Lap the valve by tapping and rotating the valve lapper “1” clockwise and counterclockwise.

- 2.** Clean off all of the lapping compound from the valve face and valve seat. Apply fine lapping compound on the valve face and lap the valve as described in step 1.

- 3.** Once the contacting surface of the valve face is polished and becomes shiny, apply mechanic’s blue layout fluid to make sure that there are traces of even contact in the center of the valve face.

NOTICE

Do not let the lapping compound enter the gap between the valve stem and the valve guide.

TIP

After every lapping procedure, clean off the compound from the valve face and valve seat.

VALVES

ENGINE
3

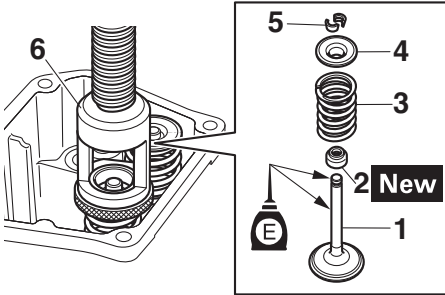

INSTALLING THE VALVES AND VALVE SPRINGS

The following procedure applies to all of the valves, valve springs and related components.

1. Install the parts below on the intake side.
 - Intake valve "1"
 - Valve stem seal "2"
 - Valve spring "3"
 - Valve spring retainer "4"
 - Valve cotter "5"Install the parts using the valve spring compressor "6".



Valve spring compressor:
90890-01253

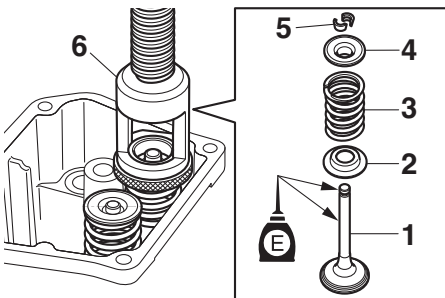

2. Install the parts below on the exhaust side.
 - Exhaust valve "1"
 - Valve spring seat "2"
 - Valve spring "3"
 - Valve spring retainer "4"
 - Valve cotter "5"Install the parts using the valve spring compressor "6".



Valve spring compressor:
90890-01253

NOTICE

Do not compress the valve spring more than necessary.

TIP

When installing the valve stem seal, do so in such a way that the outer spring "a" does not come off.

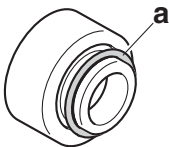

NOTICE

After installing the valves, rotate the crankshaft clockwise and check that there is no contact with the valves when the piston arrives at TDC (top-dead-center) on the compression stroke.

OIL PUMP

OIL PUMP

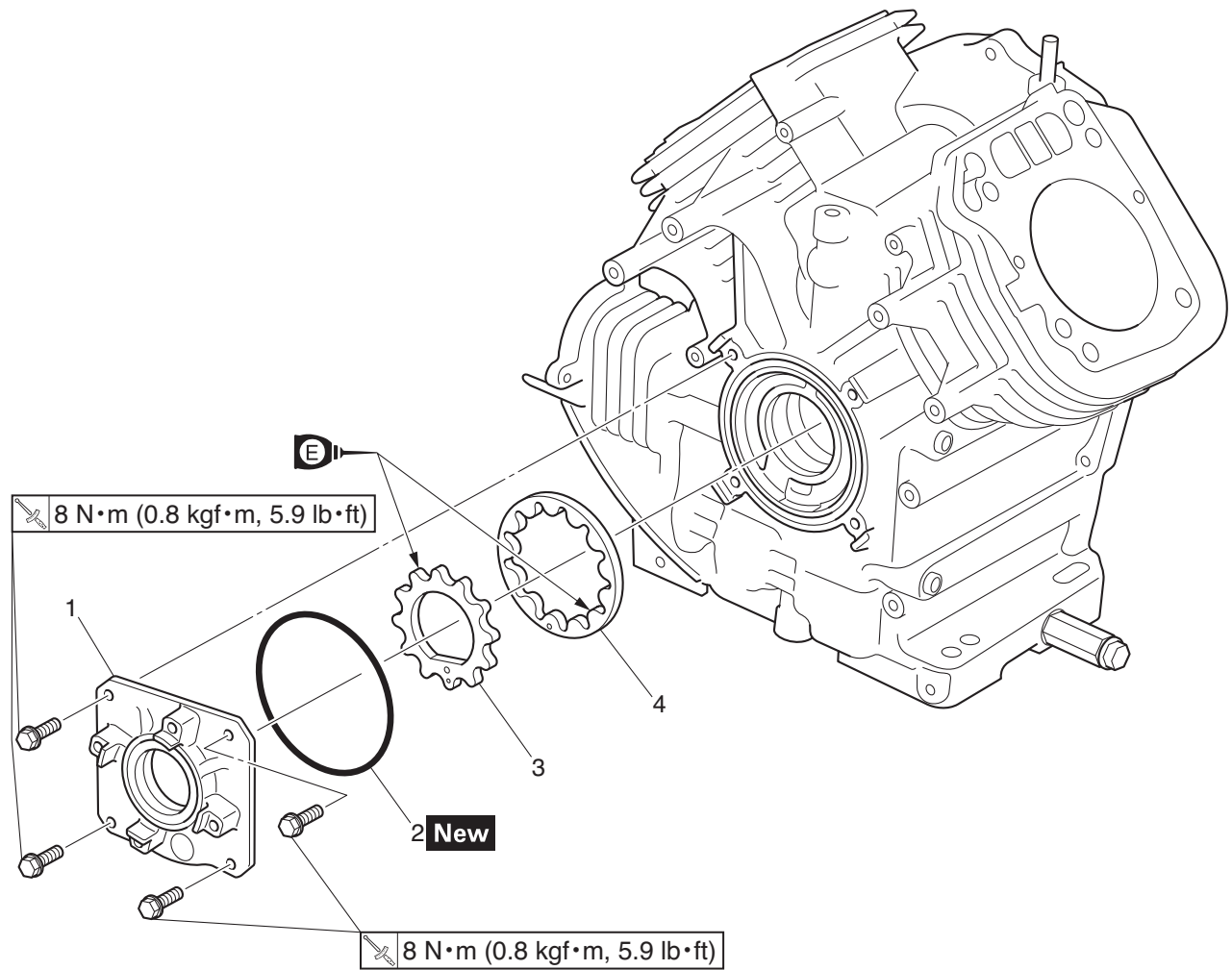

Order	Job/Parts to remove	Q'ty	Remarks
	Removing the oil pump		Remove the parts in the order listed.
	Cylinder head assembly		Refer to "CYLINDER HEAD COVERS, CYLINDER HEADS" on page 3-26.
	Crankshaft		Refer to "PISTONS, CAMSHAFT, CRANKCASE, AND CRANKSHAFT" on page 3-44.
1	Oil pump cover	1	
2	O-ring	1	
3	Inner rotor	1	
4	Outer rotor	1	

OIL PUMP

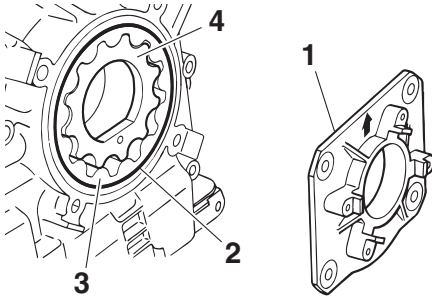

DISASSEMBLING THE OIL PUMP

1. Remove:
 - Oil pump cover “1”
2. Remove:
 - O-ring “2”
 - Outer rotor “3”
 - Inner rotor “4”

CHECKING THE OIL PUMP

1. Check:
 - Inner rotor “1”
 - Outer rotor “2”
 - Cracks/damage/wear → Replace.

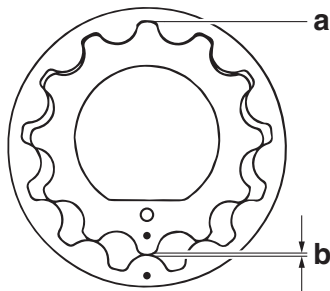
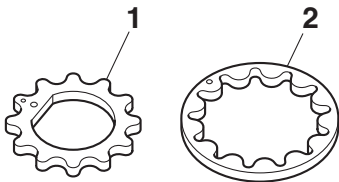

2. Measure:
 - Inner-rotor-to-outer-rotor-tip clearance “a” and “b”
 - Out of specification → Replace.

	Inner-rotor-to-outer-rotor-tip clearance “a”: 0.0 mm (0.0 in)
	Inner-rotor-to-outer-rotor-tip clearance “b”: 0.15 mm (0.0059 in)

3. Check:
 - Oil pump operation
 - Rough movement → Replace.

ASSEMBLING THE OIL PUMP

1. Install:
 - Crankshaft
 - (Refer to “PISTONS, CAMSHAFT, CRANKCASE, AND CRANKSHAFT” on page 3-44.)

TIP

Install the oil pump-related parts after installing the crankshaft. If the oil pump-related parts are installed first, the crankshaft cannot be installed properly.

OIL PUMP

2. Lubricate:
- Inner rotor
 - Outer rotor

	Recommended lubricant: Engine oil
---	--

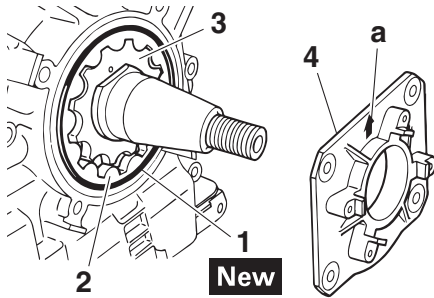

3. Install:
- O-ring “1” **New**
 - Outer rotor “2”
 - Inner rotor “3”
 - Oil pump cover “4”
 - Oil pump cover bolt

TIP
The oil pump cover should be installed with the arrow mark “a” facing upward.

	Oil pump cover bolt: 8 N·m (0.8 kgf·m, 5.9 lb·ft)
---	--

PISTONS, CAMSHAFT, CRANKCASE, AND CRANKSHAFT

PISTONS, CAMSHAFT, CRANKCASE, AND CRANKSHAFT CRANKCASE COVER

ENGINE
3

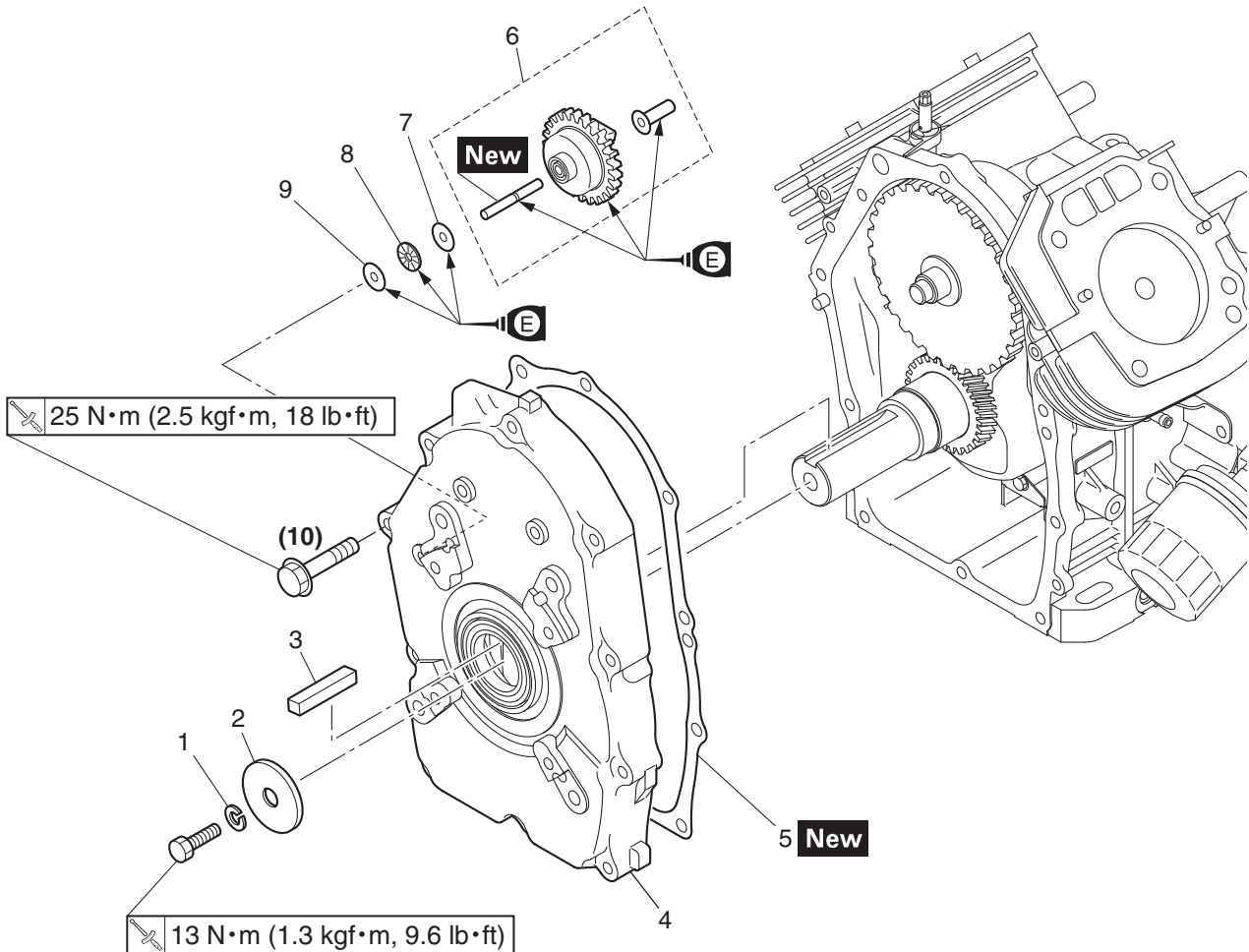

Order	Job/Parts to remove	Q'ty	Remarks
	Removing the crankcase cover		Remove the parts in the order listed.
	Cylinder head assembly		Refer to "CYLINDER HEAD COVERS, CYLINDER HEADS" on page 3-26.
1	Spring washer	1	
2	Washer	1	
3	Woodruff key	1	
4	Crankcase cover	1	
5	Gasket	1	
6	Flyweight shaft assembly	1	
7	Washer	1	
8	Thrust bearing	1	
9	Washer	1	

PISTONS, CAMSHAFT, CRANKCASE, AND CRANKSHAFT

CAMSHAFT

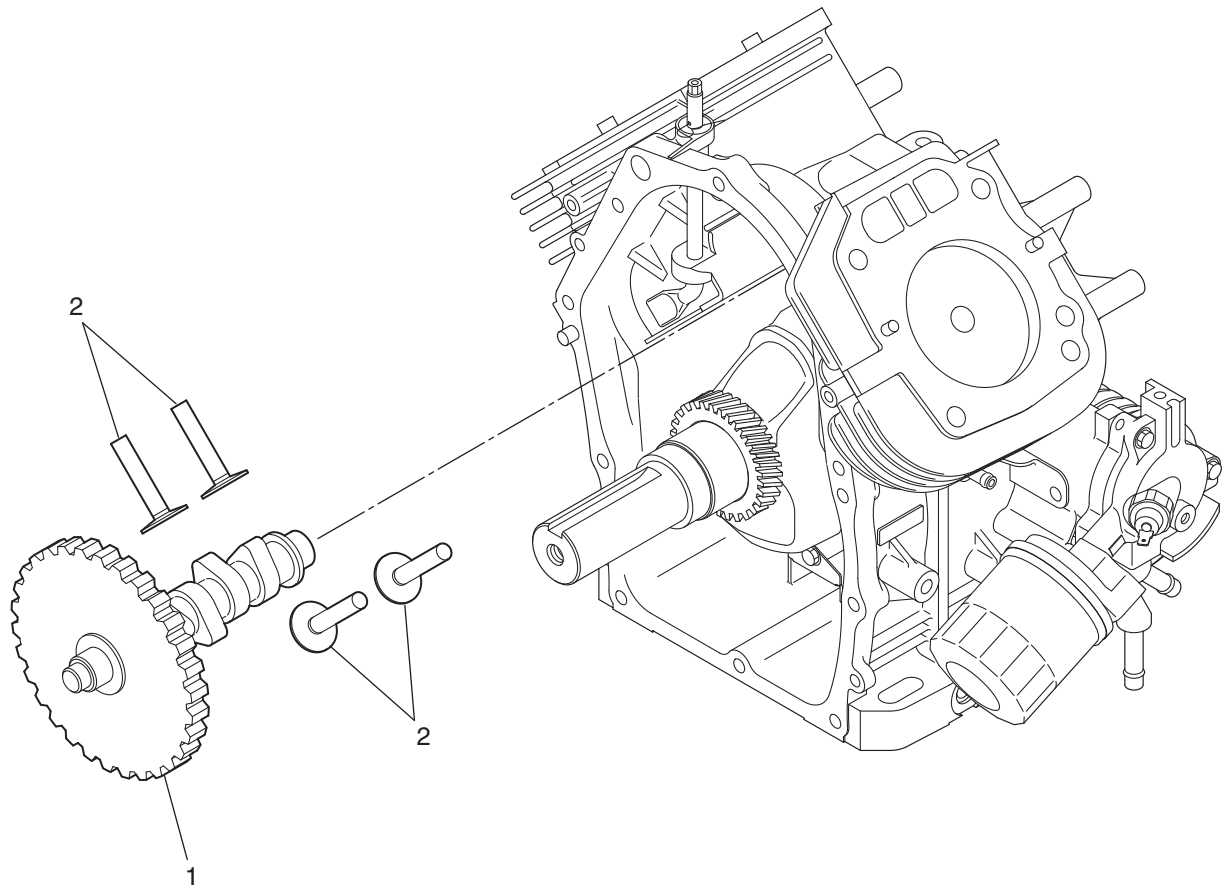

Order	Job/Parts to remove	Q'ty	Remarks
	Removing the camshaft		Remove the parts in the order listed.
1	Camshaft	1	
2	Valve lifter	4	

PISTONS, CAMSHAFT, CRANKCASE, AND CRANKSHAFT

PISTONS AND CRANKSHAFT

ENGINE 3

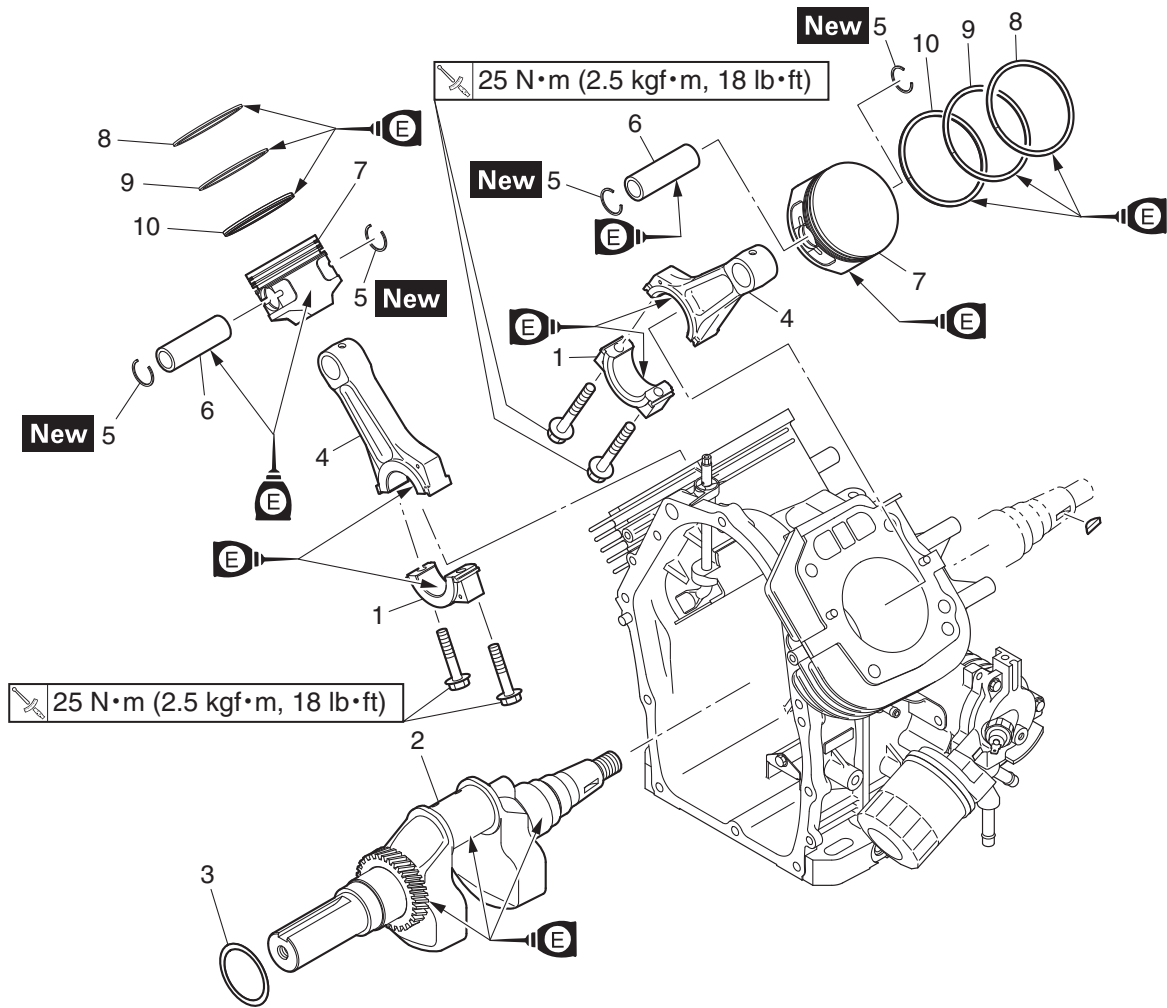

Order	Job/Parts to remove	Q'ty	Remarks
	Removing the pistons and crankshaft		Remove the parts in the order listed.
1	Connecting rod cap	2	
2	Crankshaft	1	
3	Crankshaft shim	1	
4	Connecting rod	2	
5	Piston pin circlip	4	
6	Piston pin	2	
7	Piston	2	
8	Piston ring	2	Top ring
9	Piston ring	2	2nd ring
10	Piston ring	2	Oil ring

PISTONS, CAMSHAFT, CRANKCASE, AND CRANKSHAFT

CRANKCASE

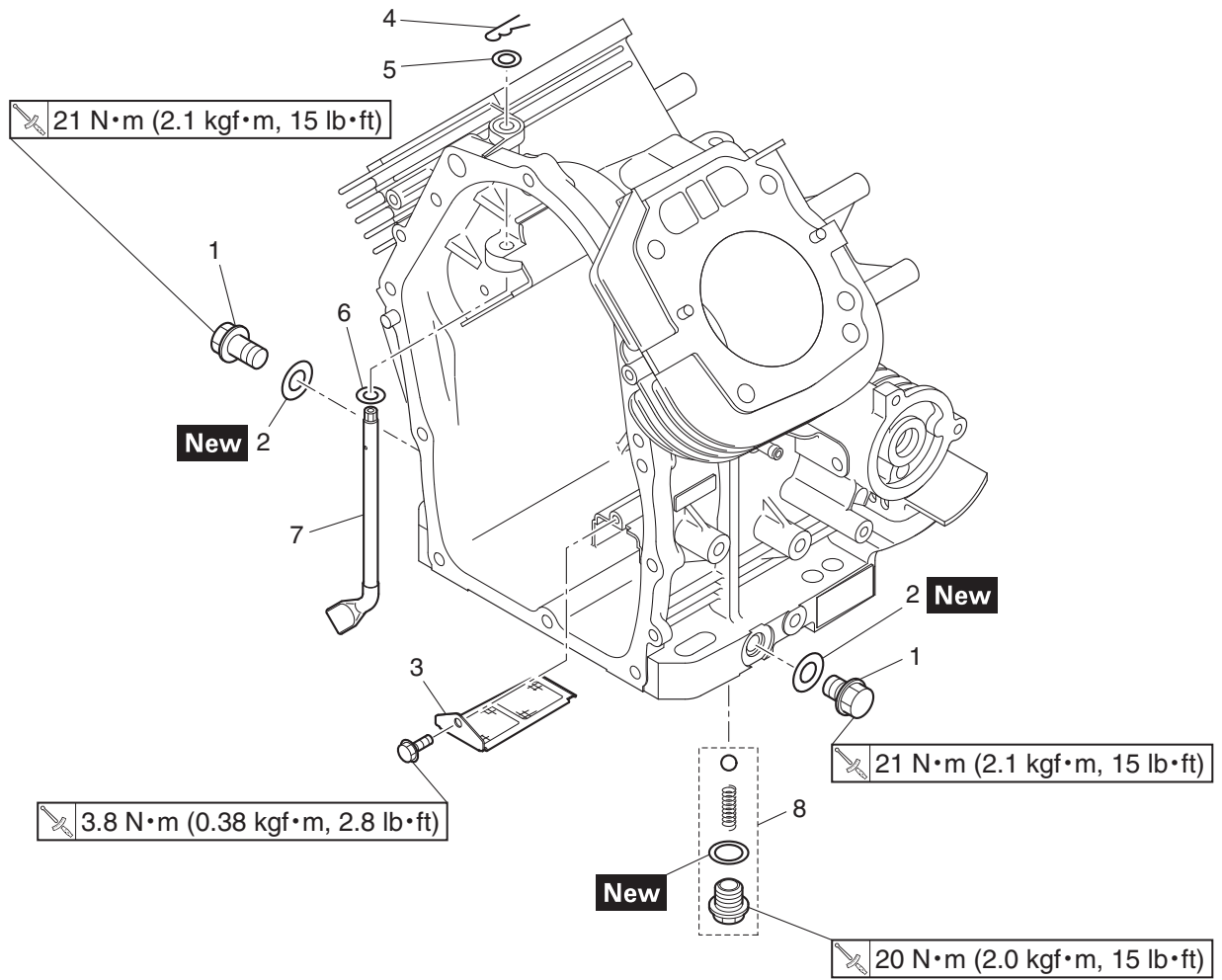

Order	Job/Parts to remove	Q'ty	Remarks
	Removing the crankcase		Remove the parts in the order listed.
1	Oil drain bolt	2	
2	Gasket	2	
3	Oil pump strainer	1	
4	Clip	1	
5	Washer	1	
6	Washer	1	
7	Governor fork	1	
8	Relief valve	1	

PISTONS, CAMSHAFT, CRANKCASE, AND CRANKSHAFT

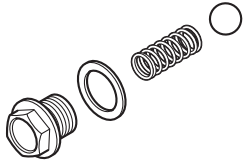

CHECKING THE RELIEF VALVE

1. Check:
 - Relief valveDamage/wear/seizure → Replace.

	Relief valve operating pressure: 373 kPa (3.73 kgf/cm ² , 54.09 psi)
---	---

ASSEMBLING THE RELIEF VALVE

1. Install:
 - Relief valve

	Relief valve: 20 N·m (2.0 kgf·m, 15 lb·ft)
---	--

CHECKING THE OIL PUMP STRAINER

1. Check:
 - Oil pump strainerCracks/damage → Replace.

ASSEMBLING THE OIL PUMP STRAINER

1. Install:
 - Oil pump strainer
 - Oil pump strainer bolt

	Oil pump strainer bolt: 3.8 N·m (0.38 kgf·m, 2.8 lb·ft)
---	---

REMOVING THE FLYWEIGHT SHAFT ASSEMBLY AND GOVERNOR FORK

1. Remove:
 - Crankcase cover
 - Governor assembly
2. Remove:
 - Clip "1"
 - Governor fork "2"
 - Washer "3"

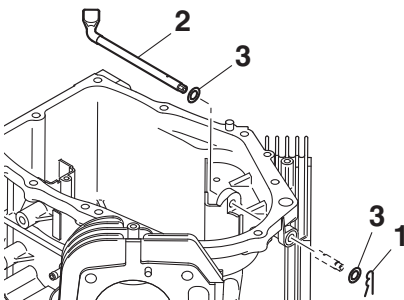

PISTONS, CAMSHAFT, CRANKCASE, AND CRANKSHAFT

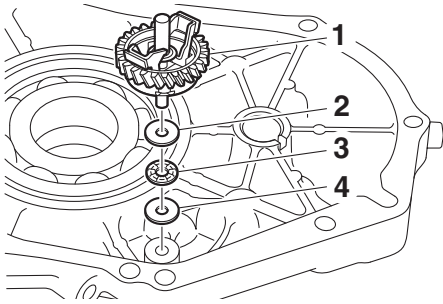

3. Remove:
 - Flyweight shaft assembly “1”
 - Washer “2”
 - Thrust bearing “3”
 - Washer “4”

TIP
Remove the flyweight shaft assembly by tapping the weight shaft from outside of the crankcase cover.

DISASSEMBLING THE FLYWEIGHT SHAFT ASSEMBLY

1. Remove:
 - Flyweight shafts “1”
 - Weights “2”
 - Collar “3”
 - Weight shaft “4”

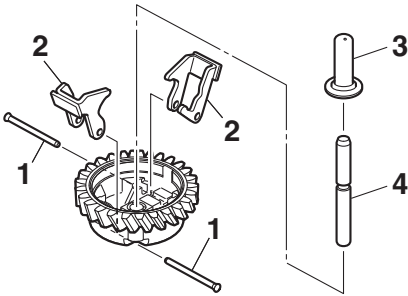

CHECKING THE FLYWEIGHT SHAFT ASSEMBLY

1. Check:
 - Flyweight shaft assembly move smoothly
 - Rough movement → Replace.

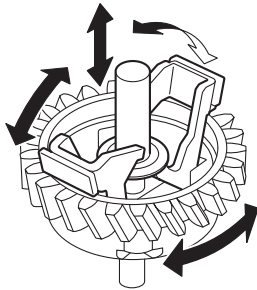

2. Check:
 - Weights
 - Flyweight shafts
 - Collar
 - Weight shaft
 - Wear/damage → Replace.

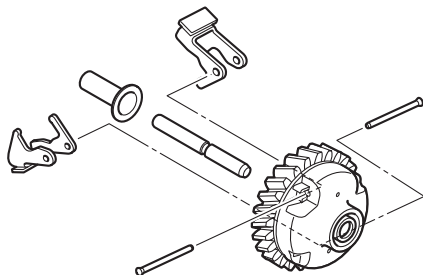

PISTONS, CAMSHAFT, CRANKCASE, AND CRANKSHAFT

ASSEMBLING THE FLYWEIGHT SHAFT ASSEMBLY

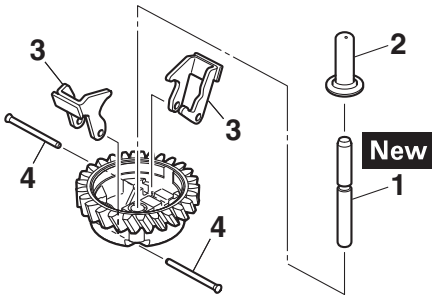

1. Install:
 - Weight shaft "1" **New**
 - Collar "2"
 - Weights "3"
 - Flyweight shafts "4"

INSTALLING THE FLYWEIGHT SHAFT ASSEMBLY AND GOVERNOR FORK

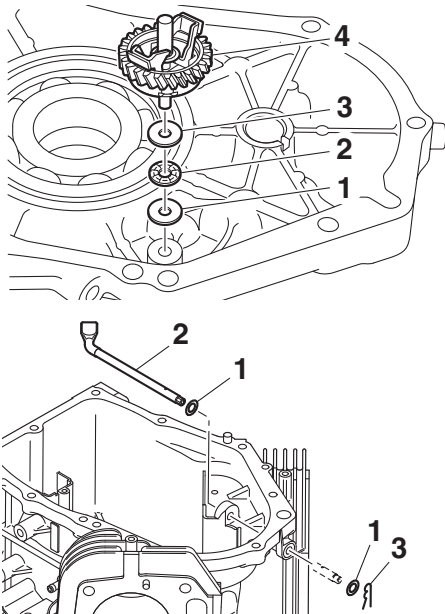

1. Install:
 - Washer "1"
 - Thrust bearing "2"
 - Washer "3"
 - Flyweight shaft assembly "4"

2. Install:
 - Washer "1"
 - Governor fork "2"
 - Clip "3"

3. Install:
 - Governor assembly
 - Crankcase cover
(Refer to "INSTALLING THE CRANKCASE COVER" on page 3-54.)

4. Adjust:
 - Governor
(Refer to "ADJUSTING THE GOVERNOR" on page 4-13.)

PISTONS, CAMSHAFT, CRANKCASE, AND CRANKSHAFT

REMOVING THE CAMSHAFT AND VALVE LIFTERS

The following procedure applies to all of the camshaft and valve lifters.

1. Remove:
 - Camshaft "1"

TIP

- Since there are two types of camshafts, refer to the illustration and check the camshaft gear mark.
- Remove the camshaft "1" when the camshaft gear mark "a" and the crankshaft gear mark "b" are aligned as shown.

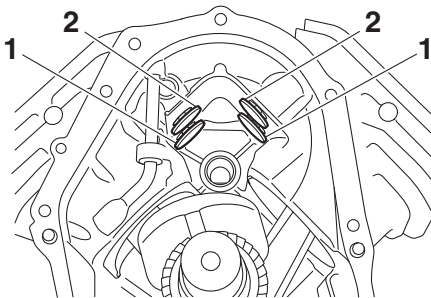
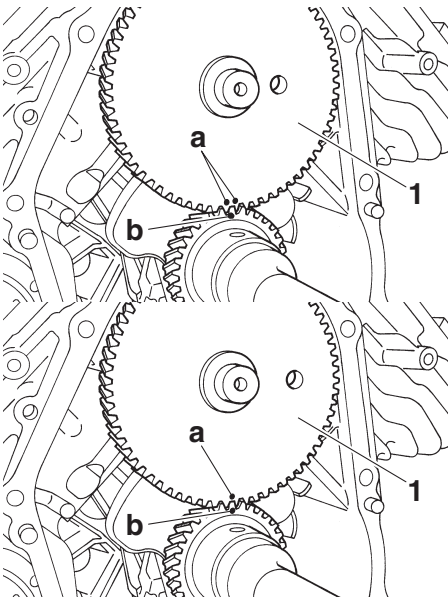

2. Remove:
 - Intake valve lifters "1"
 - Exhaust valve lifters "2"

NOTICE

Mark so as not to confuse the valve lifters when installing.

CHECKING THE CAMSHAFT

1. Check:
 - Camshaft
 - Cracks/damage/wear → Replace.

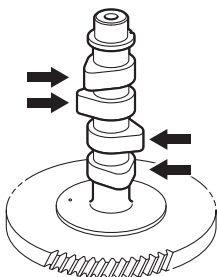

PISTONS, CAMSHAFT, CRANKCASE, AND CRANKSHAFT

ENGINE 3

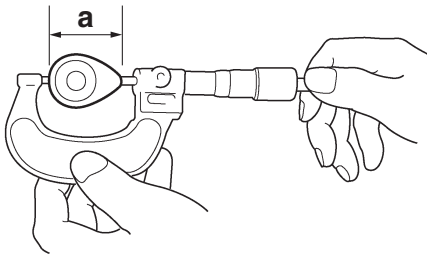

- 2.** Check:
- Camshaft lobe dimensions “a”



Camshaft lobe dimensions:

Lobe height “a” (Intake):

- 35.26–35.46 mm (1.3881–1.3960 in) (EH63K/EH64A/EH64K/EH65A/EH65B)
- 35.56–35.76 mm (1.3999–1.4078 in) (EH72A/EH72B/EH72K)

Limit:

- 35.16 mm (1.3842 in) (EH63K/EH64A/EH64K/EH65A/EH65B)
- 35.46 mm (1.3960 in) (EH72A/EH72B/EH72K)

Lobe height “a” (Exhaust):

- 35.26–35.46 mm (1.3881–1.3960 in) (EH63K/EH64A/EH64K/EH65A/EH65B)
- 35.88–36.08 mm (1.4125–1.4204 in) (EH72A/EH72B/EH72K)

Limit:

- 35.16 mm (1.3842 in) (EH63K/EH64A/EH64K/EH65A/EH65B)
- 35.78 mm (1.4086 in) (EH72A/EH72B/EH72K)

Out of specification → Replace.

- 3.** Check:
- Camshaft gear teeth
 - Cracks/damage/wear → Replace.

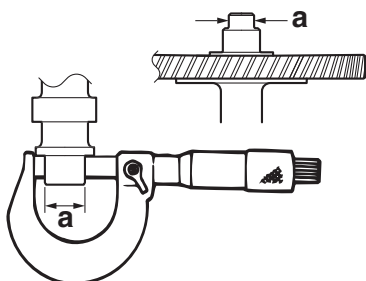
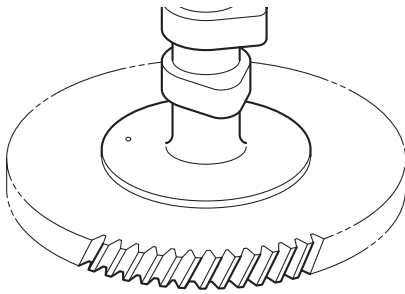

- 4.** Check:
- Camshaft journal diameter “a”



Camshaft journal diameter:

- 19.967–19.980 mm (0.7861–0.7866 in)

Limit:

- 19.950 mm (0.785 in)

Out of specification → Replace.

PISTONS, CAMSHAFT, CRANKCASE, AND CRANKSHAFT

CHECKING THE VALVE LIFTERS

1. Check:
 - Valve lifterDamage → Replace.

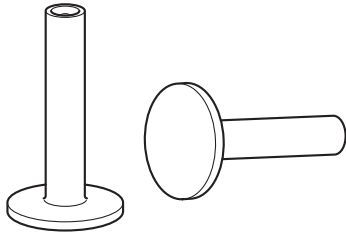

INSTALLING THE VALVE LIFTERS AND CAMSHAFT

1. Install:
 - Intake valve lifters “1”
 - Exhaust valve lifters “2”

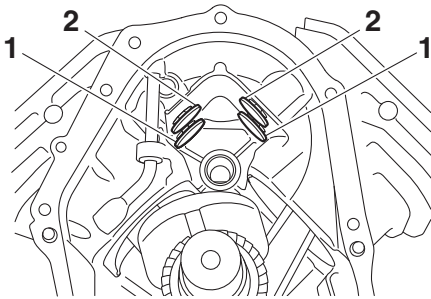

2. Install:
 - Camshaft “1”

NOTICE

- Since there are two types of camshafts, refer to the illustration and check the camshaft gear mark.
- Be sure to align the camshaft “1” gear mark “a” with the crankshaft gear mark “b”.
- After installing the intake and exhaust valves, rotate the crankshaft clockwise and check that there is no contact with the valves when the piston arrives at TDC (top-dead-center) on the compression stroke.

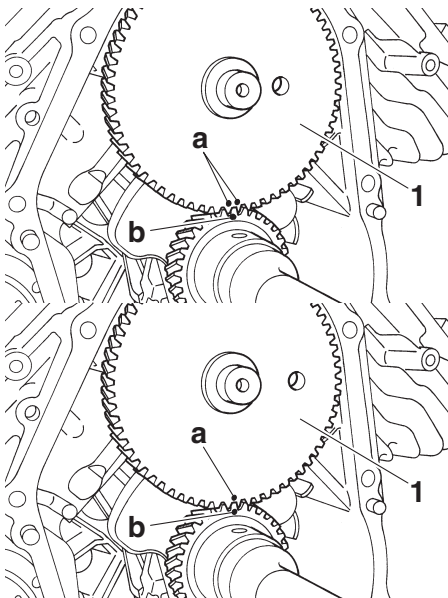

CHECKING THE CRANKCASE COVER

1. Check:
 - Crankcase coverDamage → Replace.
- Bearing
- Noise/wear/rotational failure → Replace.

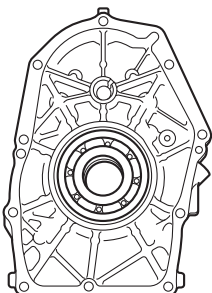

PISTONS, CAMSHAFT, CRANKCASE, AND CRANKSHAFT

ENGINE

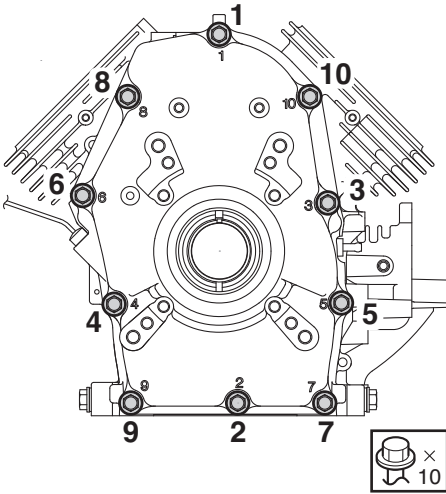

INSTALLING THE CRANKCASE COVER

- 1.** Install:
 - Crankcase cover
 - Crankcase cover bolts “1”–“10”

	Crankcase cover bolt: 25 N·m (2.5 kgf·m, 18 lb·ft)
---	---

CHECKING THE CYLINDERS AND PISTONS

- 1.** Check:
 - Piston wall
 - Cylinder wall
Vertical scratches → Replace the cylinder, and replace the piston and piston rings as a set.
- 2.** Measure:
 - Cylinder warpage

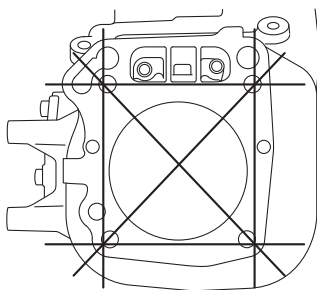

TIP _____
 Measure the warpage on the contact surface of the cylinder head at six points using a straight edge and thickness gauge.

	Thickness gauge: 90890-03268 Feeler gauge set: YU-26900-9
---	--

	Warpage limit: 0.1 mm (0.0039 in)
---	--

Out of specification → Replace the crankcase assembly.

- 3.** Measure:
 - Piston-to-cylinder clearance
 - a. Measure the cylinder bore “C” with the cylinder bore gauge.

PISTONS, CAMSHAFT, CRANKCASE, AND CRANKSHAFT

TIP

Measure cylinder bore “C” by taking side-to-side and front-to-back measurements of the cylinder.



Bore:

80.000–80.019 mm (3.1496–3.1503 in)
(EH63K/EH64A/EH64K/EH65A/EH65B)
84.000–84.022 mm (3.3070–3.3079 in)
(EH72A/EH72B/EH72K)

Warpage limit:

0.1 mm (0.0039 in)

“C” = maximum of D1, D2, D3, D4, D5, D6

b. If out of specification, replace the crankcase assembly, and replace the piston and piston rings as a set.

c. Measure piston skirt diameter “P” with the micrometer.

a = 13.0 mm (0.5118 in) from the piston bottom edge (EH63K/EH64A/EH64K/EH65A/EH65B)

a = 10.0 mm (0.3937 in) from the piston bottom edge (EH72A/EH72B/EH72K)



Piston diameter:

79.960–79.980 mm (3.1480–3.1488 in)
(EH63K/EH64A/EH64K/EH65A/EH65B)
83.980–84.000 mm (3.3062–3.3070 in)
(EH72A/EH72B/EH72K)

Limit:

79.878 mm (3.1447 in) (EH63K/EH64A/
EH64K/EH65A/EH65B)
83.890 mm (3.3027 in) (EH72A/EH72B/
EH72K)

d. If out of specification, replace the piston and piston rings as a set.

e. Calculate the piston-to-cylinder clearance with the following formula.

Piston-to-cylinder clearance = Cylinder bore “C” – Piston skirt diameter “P”

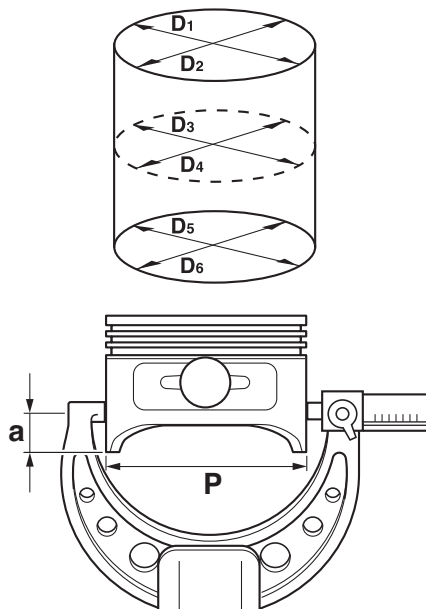

PISTONS, CAMSHAFT, CRANKCASE, AND CRANKSHAFT



Piston-to-cylinder clearance:

0.012–0.051 mm (0.0004–0.0020 in) (EH63K/
EH64A/EH64K/EH65A/EH65B)

0–0.042 mm (0–0.0016 in) (EH72A/EH72B/
EH72K)

Limit:

0.15 mm (0.0059 in)

- f. If out of specification, replace the crankcase assembly, and replace the piston and piston rings as a set.

CHECKING THE CRANKCASE

1. Check:

- Crankcase
Damage → Replace.
- Bearing
Noise/wear/rotational failure → Replace.

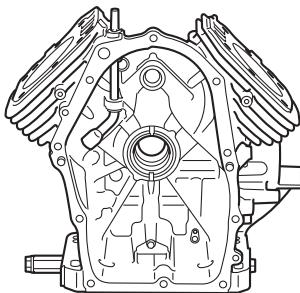

CHECKING THE PISTON PINS

1. Check:

- Piston pin
Blue discoloration/grooves → Replace the piston pin, and then check the lubrication system.

2. Measure:

- Piston pin hole inside diameter “a”
Out of specification → Replace.

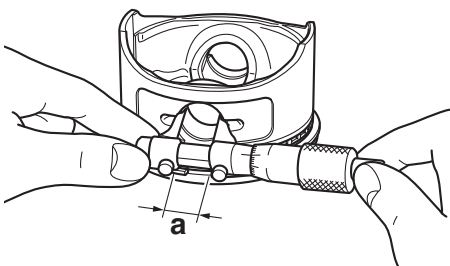

Piston pin hole inside diameter:

21.002–21.011 mm (0.8268–0.8272 in)

Limit:

21.041 mm (0.8283 in)

3. Measure:

- Piston pin diameter “a”
Out of specification → Replace.

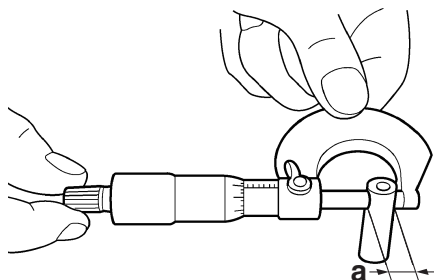

Piston pin diameter:

20.989–21.002 mm (0.8263–0.8268 in)

Limit:

20.969 mm (0.8255 in)

PISTONS, CAMSHAFT, CRANKCASE, AND CRANKSHAFT

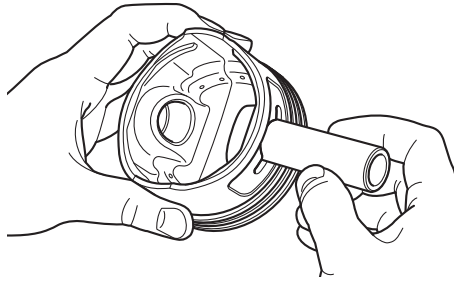

4. Check:

- Check that the piston pin enters smoothly into the piston pin hole.

TIP

If the piston pin fits too tight into the piston, check the piston pin hole. If there is any protrusion, use a knife or scraper to gently remove it so that piston pin can be pushed in smoothly with your fingers.

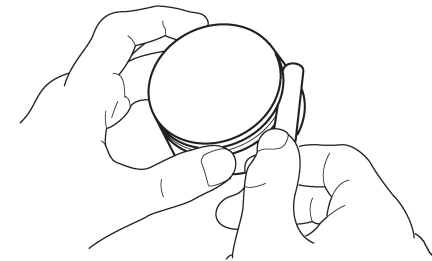

CHECKING THE PISTON RINGS

The following procedure applies to all of the piston rings.

1. Measure:

- Piston ring side clearance
Out of specification → Replace the piston and piston rings as a set.

TIP

Before measuring the piston ring side clearance, eliminate any carbon deposits from the piston ring grooves and piston rings.

	Piston ring
	Top ring
	Side clearance: 0.05–0.09 mm (0.0019–0.0035 in)
	Limit: 0.14 mm (0.0055 in)
	2nd ring
	Side clearance: 0.03–0.07 mm (0.0012–0.0028 in)
	Limit: 0.13 mm (0.0051 in)

2. Install:

- Piston ring
(into the cylinder)

TIP

Use the piston crown to level the piston ring near bottom of cylinder “a”, where cylinder wear is lowest.

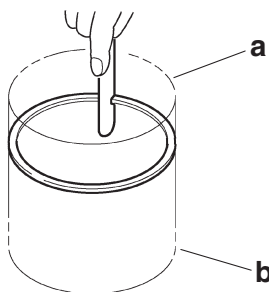

b. Upper part of cylinder

3. Measure:

- Piston ring end gap
Out of specification → Replace the piston rings as a set.

PISTONS, CAMSHAFT, CRANKCASE, AND CRANKSHAFT

	Top ring
	End gap (installed): 0.20–0.40 mm (0.0079–0.0157 in)
	Limit: 1.50 mm (0.0590 in)
	2nd ring
	End gap (installed): 0.20–0.40 mm (0.0079–0.0157 in)
	Limit: 1.50 mm (0.0590 in)
	Oil ring
	End gap (installed): 0.20–0.70 mm (0.0079–0.0276 in)
	Limit: 1.50 mm (0.0590 in)

CHECKING THE CRANKSHAFT

1. Check:
 - Crankshaft sprocket “1”
Damage/wear → Replace the crankshaft.

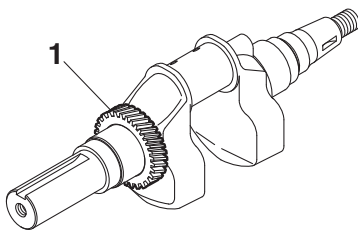

2. Measure:
 - Crank pin outside diameter “a”
Out of specification → Replace.
Use a micrometer.

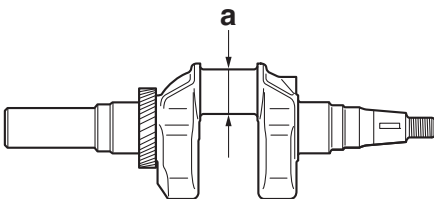

	Crank pin outside diameter: 38.956–38.970 mm (1.5336–1.5342 in)
	Limit: 38.900 mm (1.5314 in)

CHECKING THE CONNECTING RODS OIL CLEARANCE

TIP _____
Measure the oil clearance if replacing the crankshaft or connecting rod.

PISTONS, CAMSHAFT, CRANKCASE, AND CRANKSHAFT

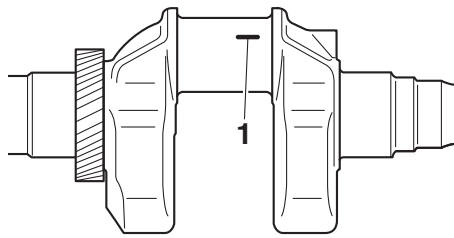

1. Place a piece of Plastigauge® “1” on the crank pin horizontally.

TIP

Wipe off oil thoroughly from the crankshaft, connecting rod, and connecting rod cap.

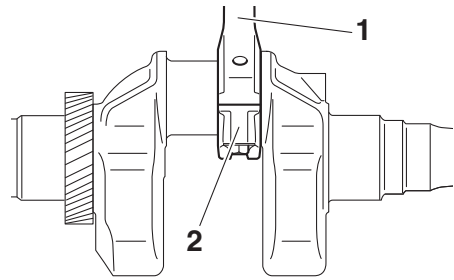

2. Install:
 - Connecting rod “1”
 - Connecting rod cap “2”



Connecting rod cap bolt:
25 N·m (2.5 kgf·m, 18 lb·ft)

3

ENGINE

INSTALLING THE PISTONS AND PISTON RINGS

The following procedure applies to all of the pistons and piston rings.

1. Install:
 - Top ring “1”
 - 2nd ring “2”
 - Oil ring “3”

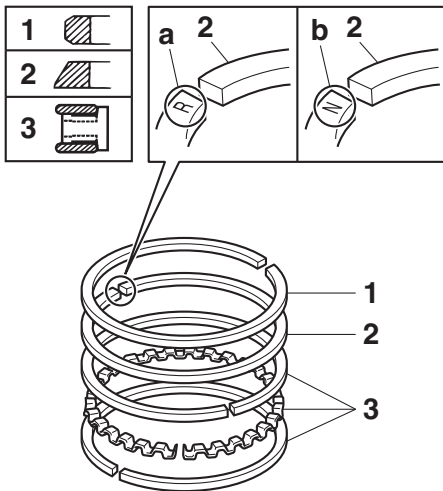

TIP

- Be sure to install the EH63K/EH64A/EH64K/EH65A/EH65B 2nd ring so that the “R” mark “a” faces toward the piston head.
- Be sure to install the EH72A/EH72B/EH72K 2nd ring so that the “N” mark “b” faces toward the piston head.
- Make sure that the piston rings move smoothly.

2. Apply the engine oil to the inside of the connecting rod small end.

PISTONS, CAMSHAFT, CRANKCASE, AND CRANKSHAFT

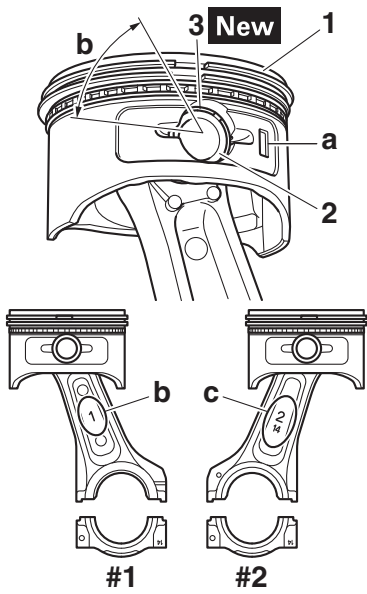

3. Install:
 - Piston "1"
 - Piston pin "2"
 - Piston pin circlip "3" **New**

- TIP**
- For the EH63K/EH64A/EH64K/EH65A/EH65B, install so that the assembly direction mark "a" side faces the flywheel side.
 - There is no installation direction mark on the EH72A/EH72B/EH72K, and either side of the piston may face the flywheel side.
 - Install the piston pin circlips so that the clip ends are 45° "b" or more from the cutout in the piston.
 - For the piston to be installed on cylinder #1, install so that the number "1" "b" on the connecting rod faces the crankcase cover side, and for the piston to be installed on cylinder #2, install so that the number "2" "c" on the connecting rod faces the crankcase cover side.

INSTALLING THE CRANKSHAFT

1. Make sure that the end gap of each piston ring is positioned correctly, as shown in the illustration.
 - a. Top ring
 - b. 2nd ring
 - c. Oil ring

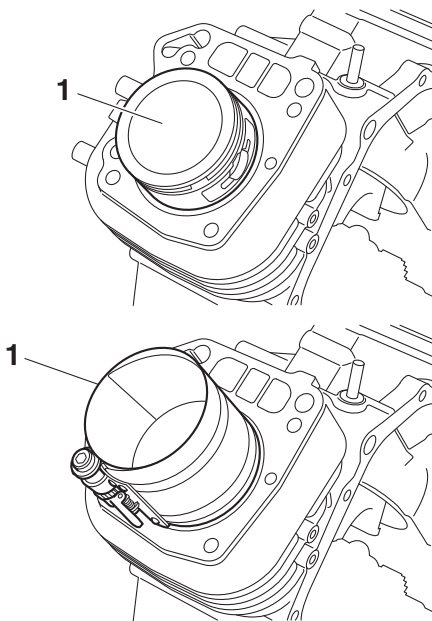
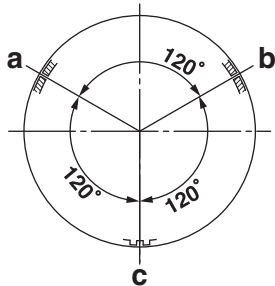

2. Install:
 - Piston with the connecting rod "1"

3. Attach:
 - Piston ring compressor "1"

	Piston ring compressor: 90890-05158, YM-08037
---	--

- TIP**
- Attach the piston ring compressor to the piston, and then insert the piston into the cylinder.

PISTONS, CAMSHAFT, CRANKCASE, AND CRANKSHAFT

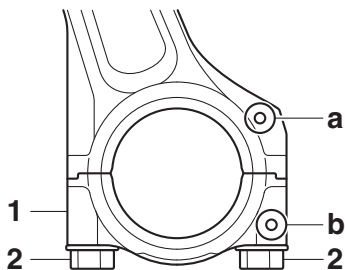
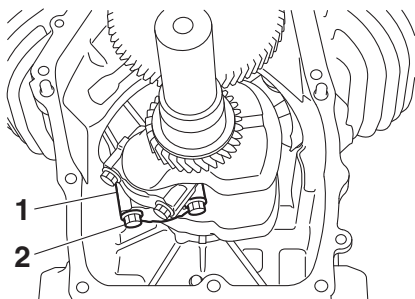
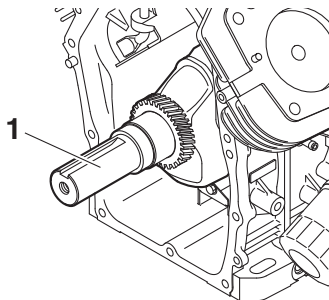
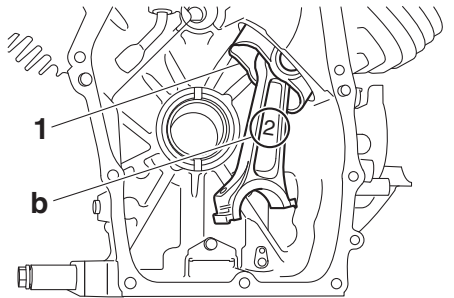
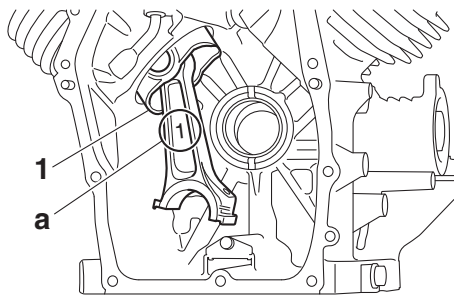

4. Check:
 - Piston with the connecting rod "1" position

TIP _____
 For cylinder #1, install so that the number "1" "a" on the connecting rod faces the crankcase cover side, and for cylinder #2, install so that the number "2" "b" on the connecting rod faces the crankcase cover side.

5. Install:
 - Crankshaft "1"

6. Install:
 - Connecting rod cap #1 "1"
 - Connecting rod cap bolts #1 "2"

	<p>Connecting rod cap bolt: 25 N·m (2.5 kgf·m, 18 lb·ft)</p>
---	--

TIP _____

- Make sure that the "○" mark "a" on the connecting rod is aligned with the "○" mark "b" on the connecting rod cap.
- Tighten the connecting rod cap bolts alternately two to three times.

PISTONS, CAMSHAFT, CRANKCASE, AND CRANKSHAFT

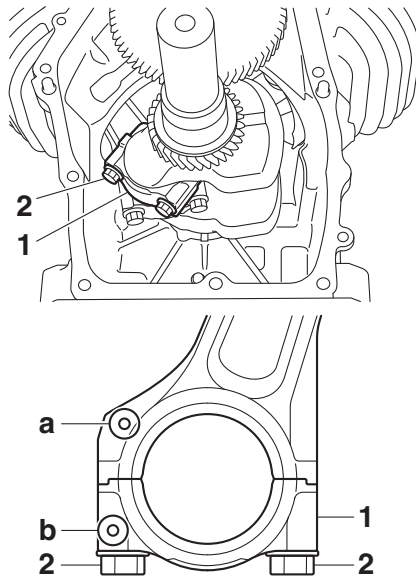

7. Install:
 - Connecting rod cap #2 "1"
 - Connecting rod cap bolts #2 "2"

	Connecting rod cap bolt: 25 N·m (2.5 kgf·m, 18 lb·ft)
---	--

- TIP**
- Make sure that the "○" mark "a" on the connecting rod is aligned with the "○" mark "b" on the connecting rod cap.
 - Tighten the connecting rod cap bolts alternately two to three times.

8. Install:
 - Camshaft
(Refer to "INSTALLING THE VALVE LIFTERS AND CAMSHAFT" on page 3-53.)
 - Crankcase cover
(Refer to "INSTALLING THE CRANKCASE COVER" on page 3-54.)

SELECTING THE CRANKSHAFT SHIM

1. Calculate:
 - Pre-adjustment clearance "X"

Calculation and adjustment procedure:

- a. Measure dimensions 1 and 2.
- b. Measure the value of the "A" part of the crankcase cover "1".
- c. Measure the value of the "B" part of the crankshaft sprocket "3" and the crankcase "4".
- d. Calculate the pre-adjustment clearance "X".
Pre-adjustment clearance "X" = (value of "A" + value when gasket "5" is tightened (0.48 mm)) - value of the "B" (dimension 1 - dimension 2)
- e. Calculate the clearance value after adjustment.
Pre-adjustment clearance "X" - Adjustment shim "2" thickness = Clearance after adjustment
- f. Install or remove an adjustment shim "2" of the proper thickness.
- g. Install the crankcase cover "1".

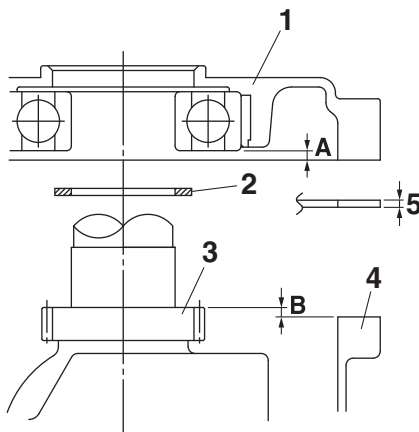

PISTONS, CAMSHAFT, CRANKCASE, AND CRANKSHAFT

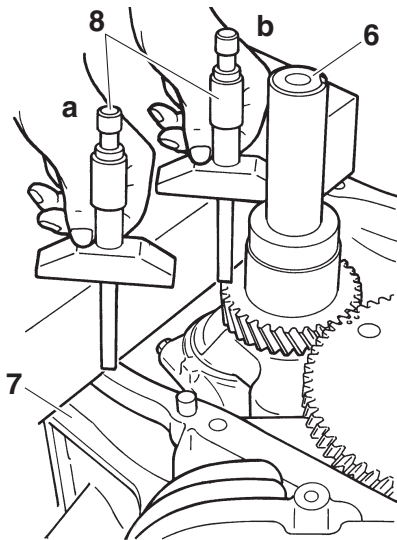

TIP

Install a depth gauge (commercially available product) "8" for measurement on crankshaft "6" and crankcase "7". Measure dimension 1 on the "a" side of the depth gauge, dimension 2 on the "b" side. Place a horizontal bar or a base on the crankcase and install a depth gauge, as shown in the illustration.

3

ENGINE

2. Select and install the parts below.

- Adjustment shim

TIP

Adjust so that the clearance value after adjustment is 0.2 mm or less.

List of adjustment shim thicknesses:

Part number	Shim thickness
7D3-11561-00	0.8 ± 0.04
7D3-11561-10	1.0 ± 0.04
7D3-11561-20	1.2 ± 0.05

PISTONS, CAMSHAFT, CRANKCASE, AND CRANKSHAFT

MEMO

3

ENGINE

FUEL

FUEL PUMP

EH63K/EH64A/EH64K/EH65A/EH65B

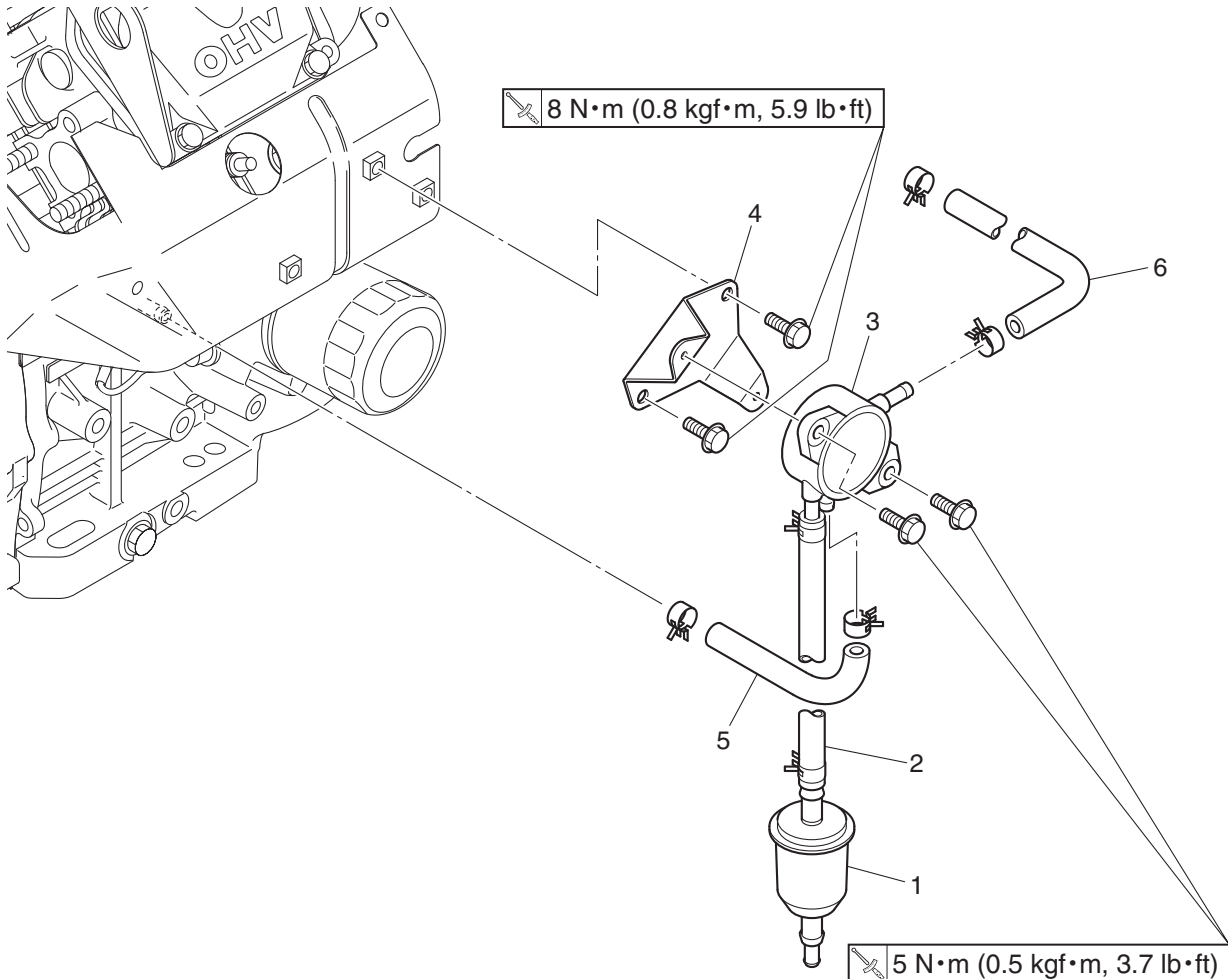

4

FUEL

Order	Job/Parts to remove	Q'ty	Remarks
	Removing the fuel pump		Remove the parts in the order listed.
1	Fuel filter	1	
2	Fuel hose	1	
3	Fuel pump	1	
4	Fuel pump bracket	1	
5	Pulsar hose	1	
6	Fuel hose (carburetor side)	1	

FUEL PUMP

EH72A/EH72B/EH72K

4
FUEL

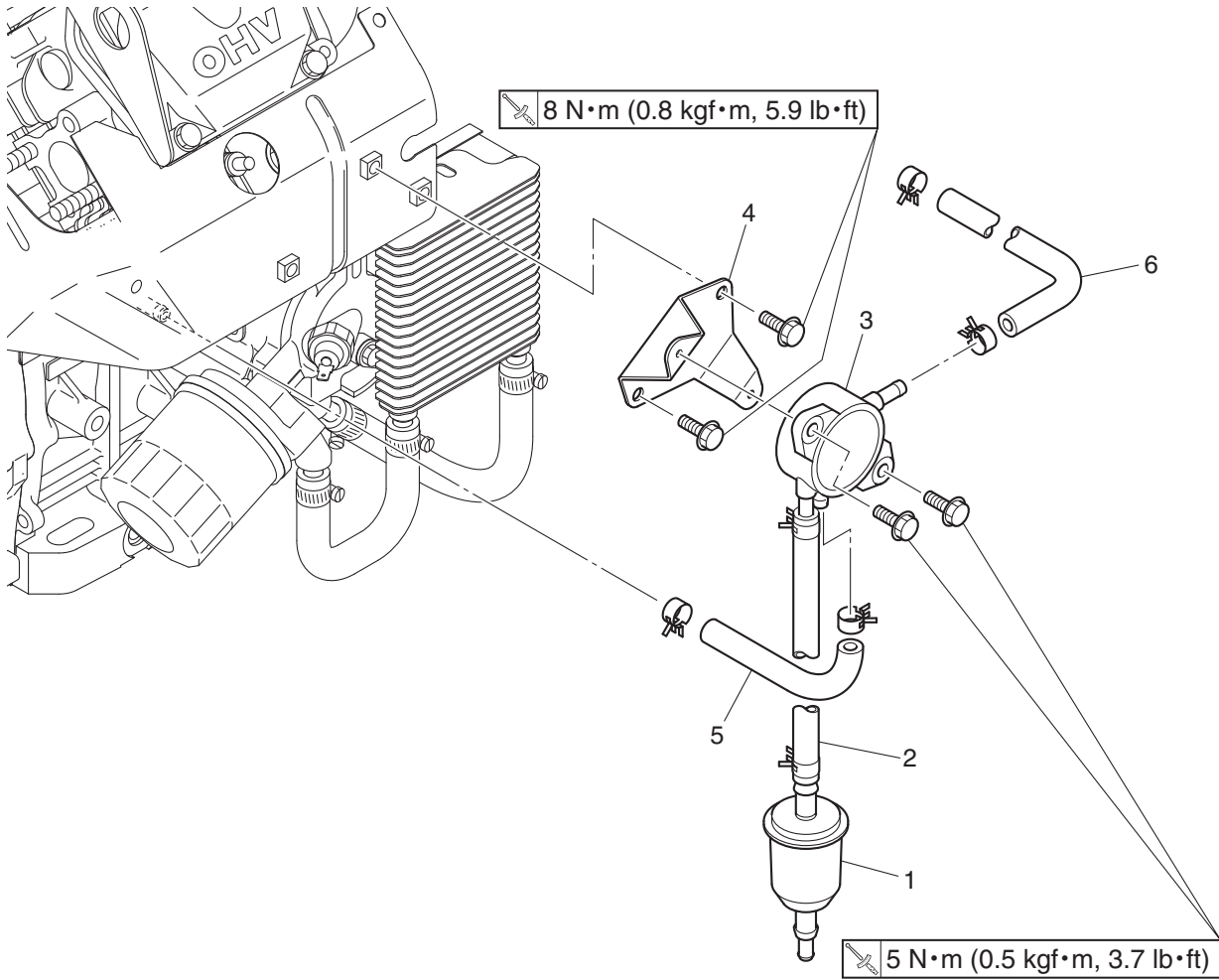

Order	Job/Parts to remove	Q'ty	Remarks
	Removing the fuel pump		Remove the parts in the order listed.
1	Fuel filter	1	
2	Fuel hose	1	
3	Fuel pump	1	
4	Fuel pump bracket	1	
5	Pulsar hose	1	
6	Fuel hose (carburetor side)	1	

CHECKING THE FUEL PUMP

1. Check:

- Fuel hose "1"
 - Fuel hose (carburetor side) "2"
 - Pulsar hose "3"
 - Fuel pump "4"
- Cracks/damage → Replace.

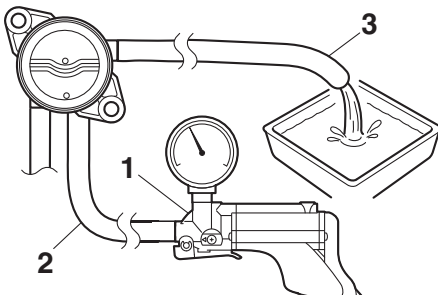
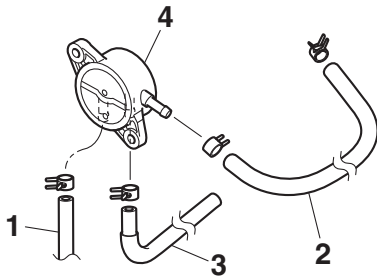

2. Check:

- Fuel pump operation

Checking steps:

- a. Connect a manual vacuum pump (vacuum/pressure pump gauge set) "1" to the pulsar hose "2".



Vacuum/pressure pump gauge set:

90890-06945

Pressure/ vacuum tester:

YB-35956-B

- b. Place the container near the lower side of the fuel hose (carburetor side) "3".
- c. Operate the manual vacuum pump (vacuum/pressure pump gauge set) "1" and check if gasoline flows out from the fuel hose (carburetor side) "3".
- d. If the gasoline does not flow out, replace the fuel pump.

CARBURETOR ASSEMBLY

CARBURETOR ASSEMBLY

REMOVING THE CARBURETOR (EH63K/EH64A/EH64K/EH65A/EH65B)

4
FUEL

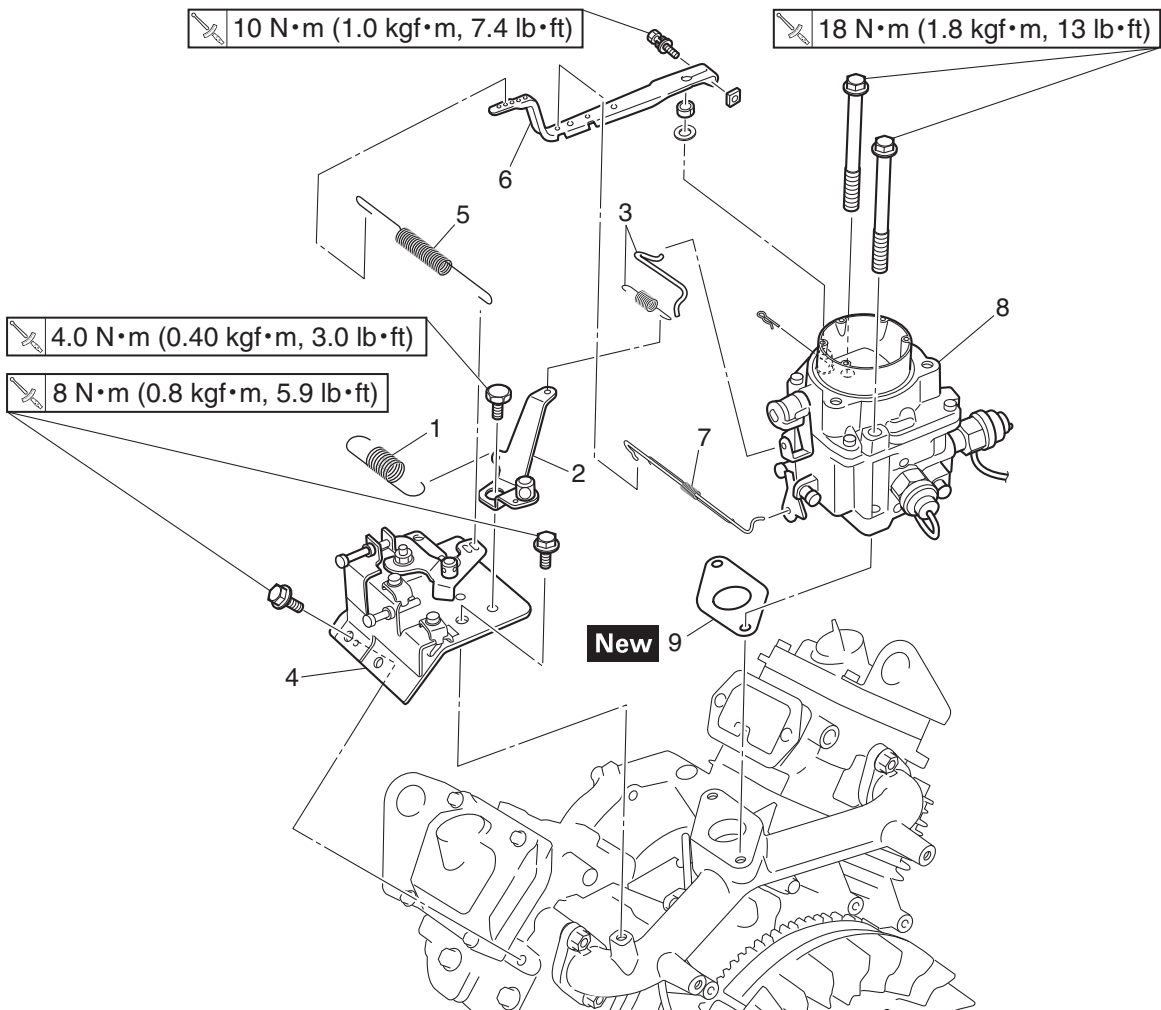

Order	Job/Parts to remove	Q'ty	Remarks
	Removing the carburetor		Remove the parts in the order listed.
	Muffler		Refer to "MUFFLER" on page 3-5.
	Air filter		Refer to "AIR FILTER" on page 3-3.
	Fan case		Refer to "CASE AND FAN" on page 3-14.
1	Spring	1	
2	Choke lever	1	
3	Choke lever rod/spring	1/1	
4	Throttle lever assembly	1	
5	Spring	1	
6	Governor arm	1	
7	Link rod/spring	1/1	
8	Carburetor assembly	1	The illustration is for EH72B.
9	Gasket	1	

CARBURETOR ASSEMBLY

DISASSEMBLING THE CARBURETOR (EH64A/EH65B)

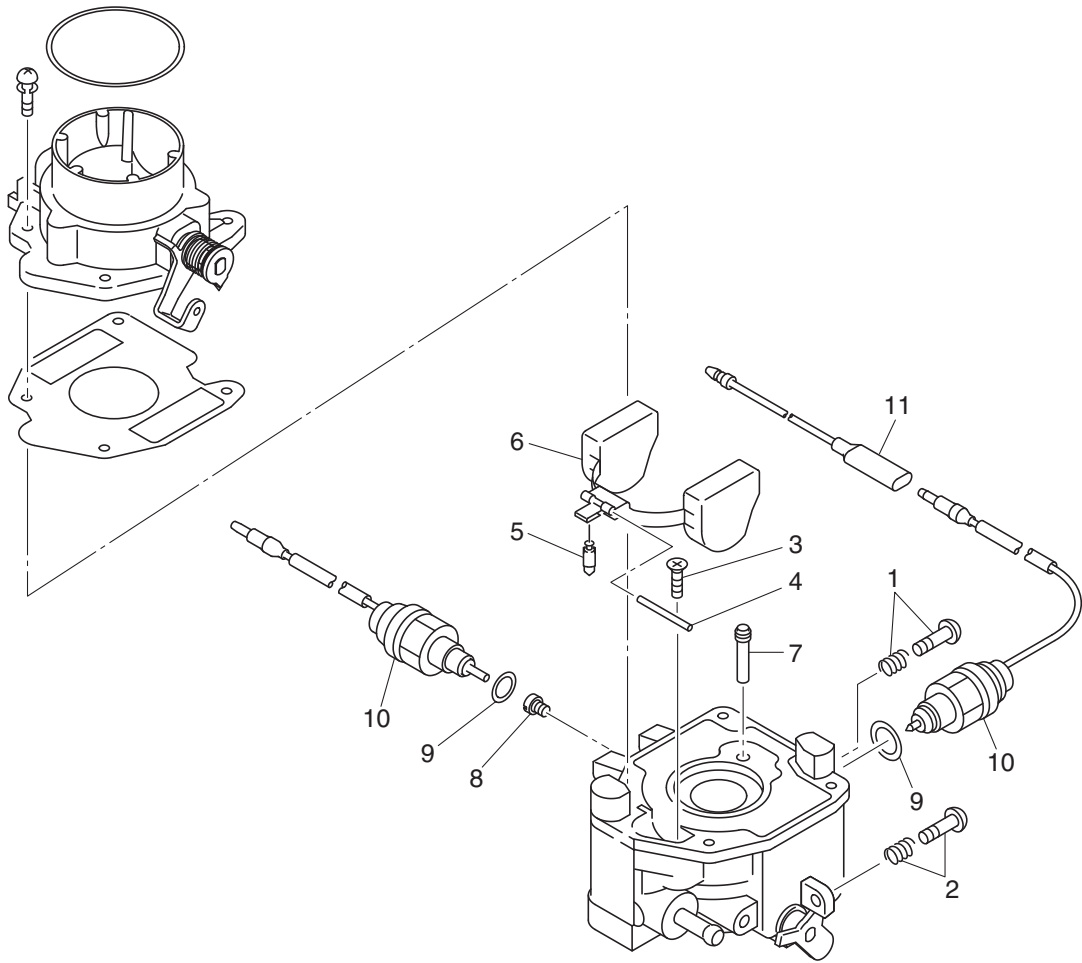

Order	Job/Parts to remove	Q'ty	Remarks
	Disassembling the carburetor		Disassemble the parts in the order listed.
1	Drain screw/spring	1/1	
2	Throttle stop screw/spring	1/1	
3	Float pin screw	1	
4	Float pin	1	
5	Float valve	1	
6	Float	1	
7	Slow jet	1	
8	Main jet	1	
9	Gasket	2	
10	Solenoid valve	2	
11	Lead assembly	1	

CARBURETOR ASSEMBLY

4
FUEL

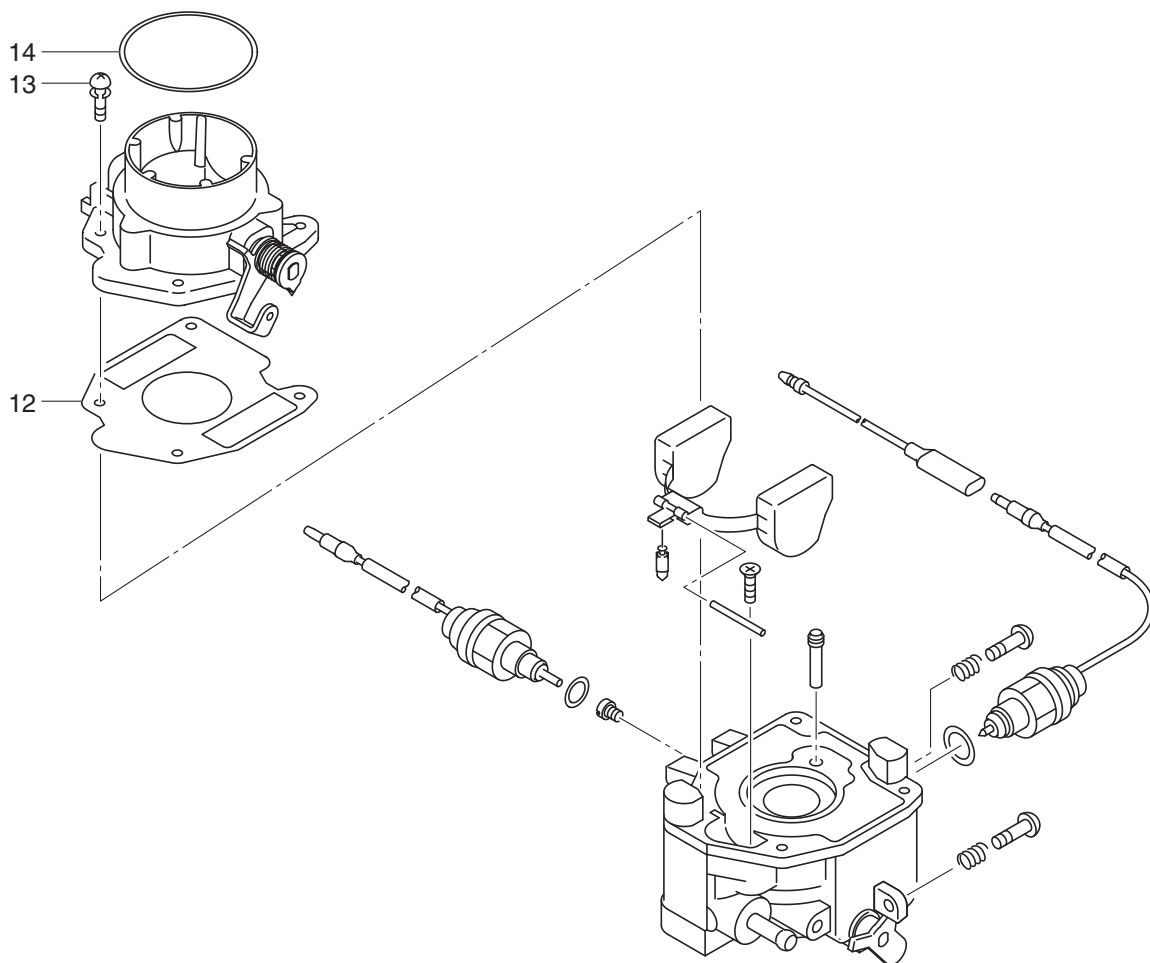

Order	Job/Parts to remove	Q'ty	Remarks
12	Gasket	1	
13	Screw	4	
14	O-ring	1	

CARBURETOR ASSEMBLY

DISASSEMBLING THE CARBURETOR (EH63K/EH64K/EH65A)

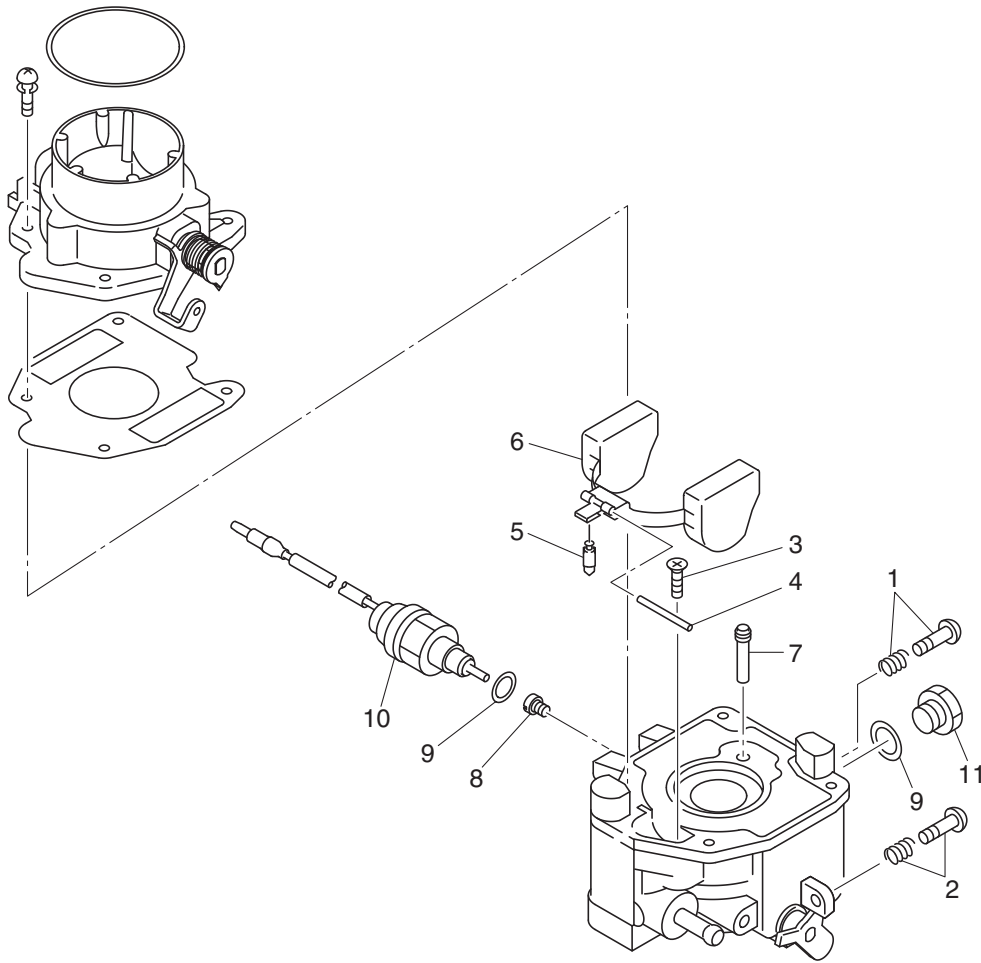

Order	Job/Parts to remove	Q'ty	Remarks
	Disassembling the carburetor		Disassemble the parts in the order listed.
1	Drain screw/spring	1/1	
2	Throttle stop screw/spring	1/1	
3	Float pin screw	1	
4	Float pin	1	
5	Float valve	1	
6	Float	1	
7	Slow jet	1	
8	Main jet	1	
9	Gasket	2	
10	Solenoid valve	1	
11	Plug	1	

CARBURETOR ASSEMBLY

4

FUEL

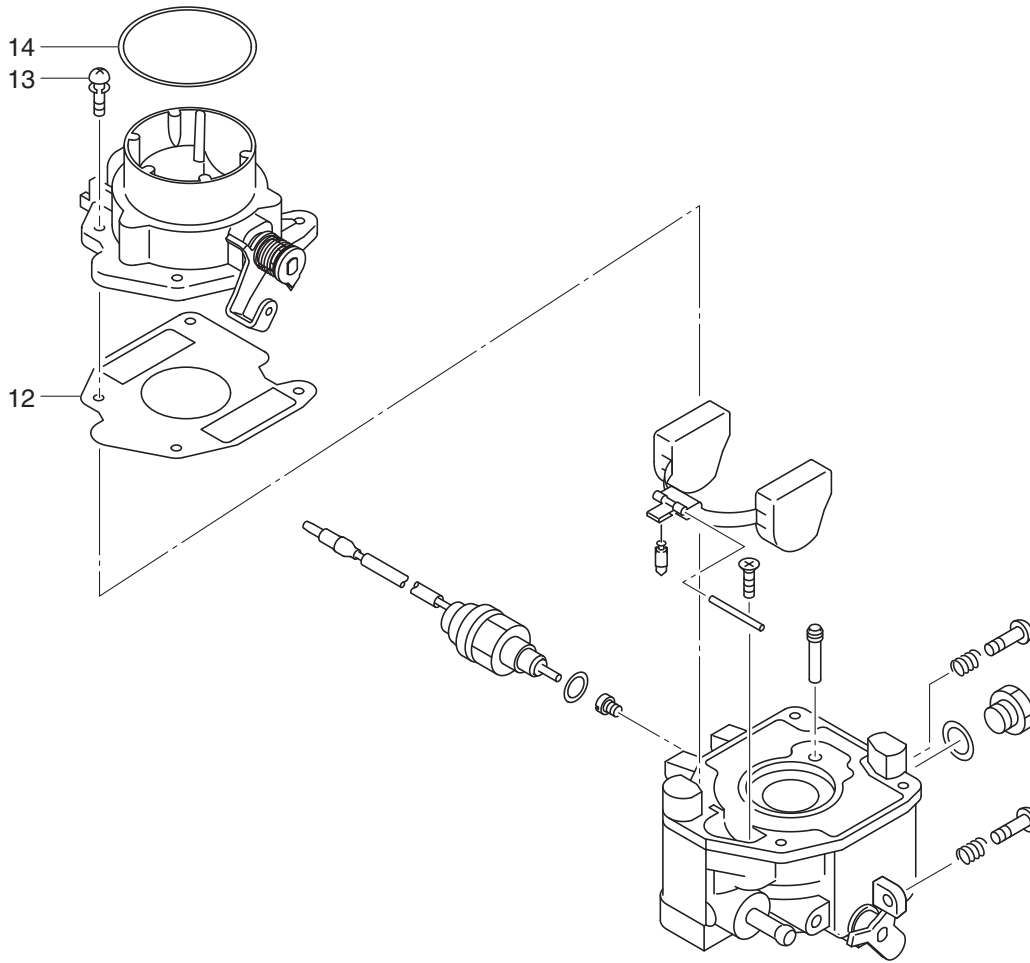

Order	Job/Parts to remove	Q'ty	Remarks
12	Gasket	1	
13	Screw	4	
14	O-ring	1	

CARBURETOR ASSEMBLY

REMOVING THE CARBURETOR (EH72A/EH72B/EH72K)

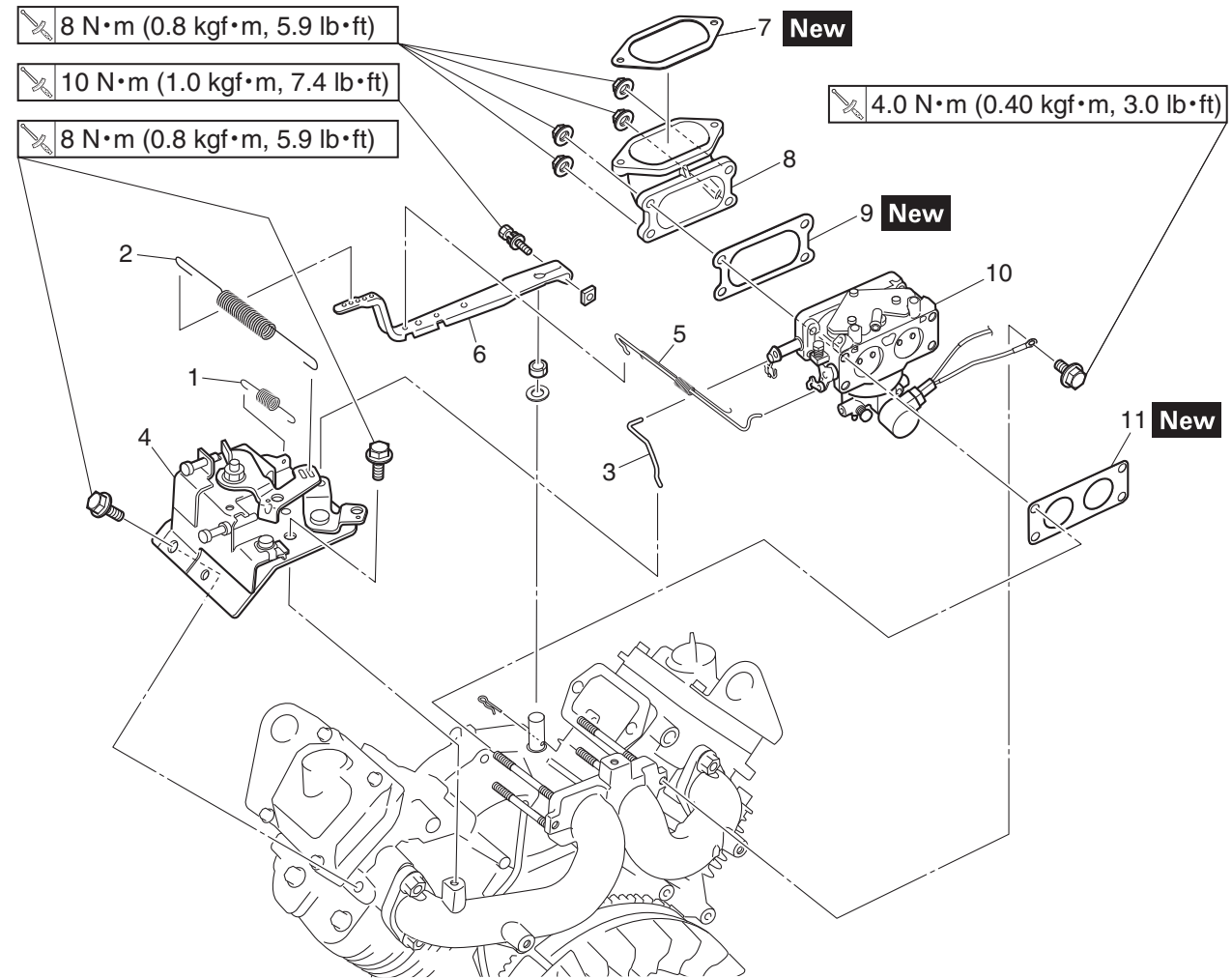

Order	Job/Parts to remove	Q'ty	Remarks
	Removing the carburetor		Remove the parts in the order listed.
	Muffler		Refer to "MUFFLER" on page 3-5.
	Air filter		Refer to "AIR FILTER" on page 3-3.
	Fan case		Refer to "CASE AND FAN" on page 3-14.
1	Spring	1	
2	Spring	1	
3	Choke lever rod	1	
4	Throttle lever assembly	1	
5	Link rod/spring	1/1	
6	Governor arm	1	
7	Gasket	1	
8	Joint	1	
9	Gasket	1	
10	Carburetor assembly	1	
11	Gasket	1	

CARBURETOR ASSEMBLY

DISASSEMBLING THE CARBURETOR (EH72A/EH72B/EH72K)

4
FUEL

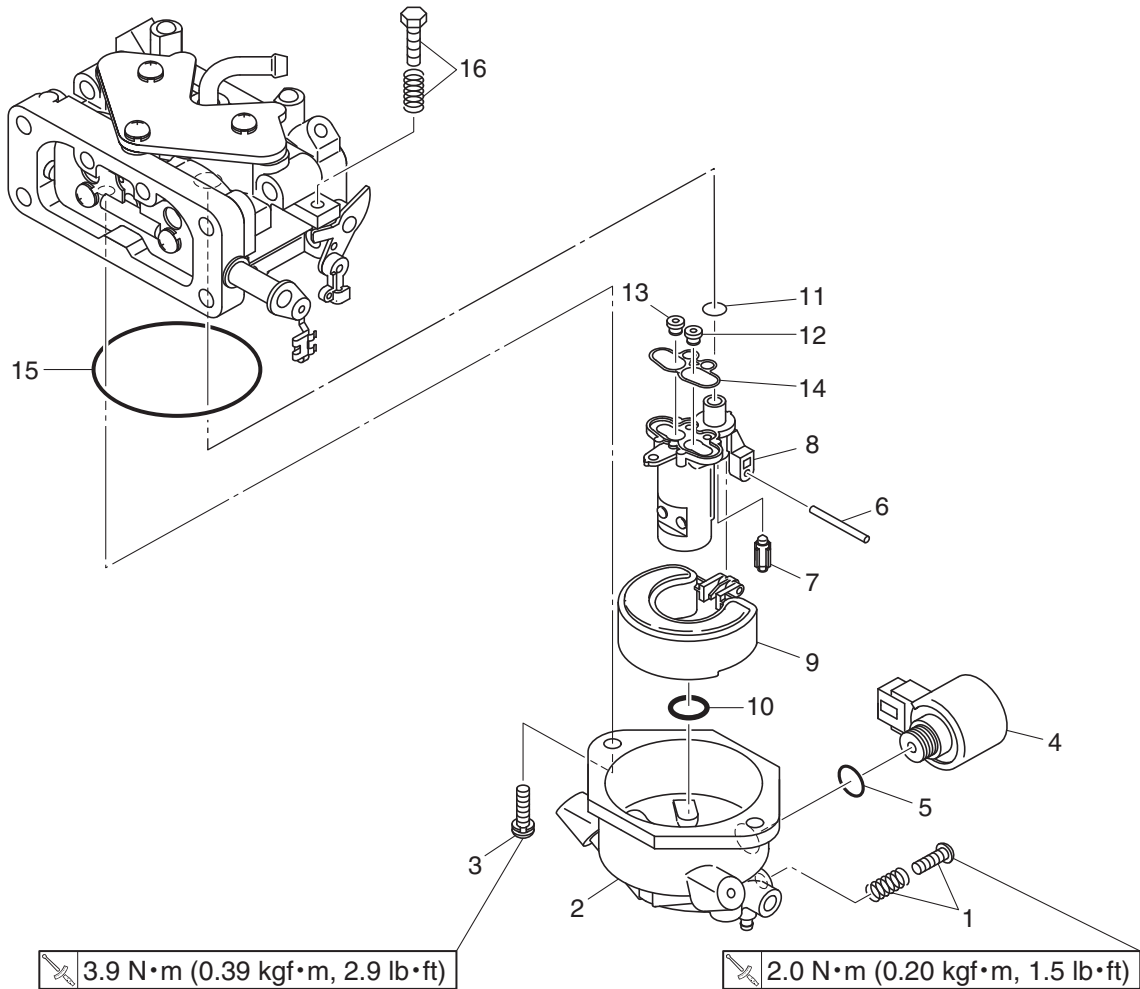

Order	Job/Parts to remove	Q'ty	Remarks
	Disassembling the carburetor		Disassemble the parts in the order listed.
1	Drain screw/spring	1/1	
2	Float chamber	1	
3	Screw	2	
4	Solenoid valve	1	
5	Gasket	1	
6	Float pin	1	
7	Float valve	1	
8	Spacer	1	
9	Float	1	
10	Gasket	1	
11	O-ring	1	
12	Main jet	1	Right side
13	Main jet	1	Left side
14	Gasket	1	
15	Gasket	1	
16	Throttle stop screw/spring	1/1	

REMOVING THE CARBURETOR ASSEMBLY

1. Remove:
 - Spring
 - Governor arm
 - Throttle lever assembly
 - Link rod/spring
2. Remove:
 - Gasket "1"
 - Carburetor assembly "2"
 - Joint (EH72A/EH72B/EH72K) "3"

- A. EH63K/EH64A/EH64K/EH65A/EH65B
B. EH72A/EH72B/EH72K

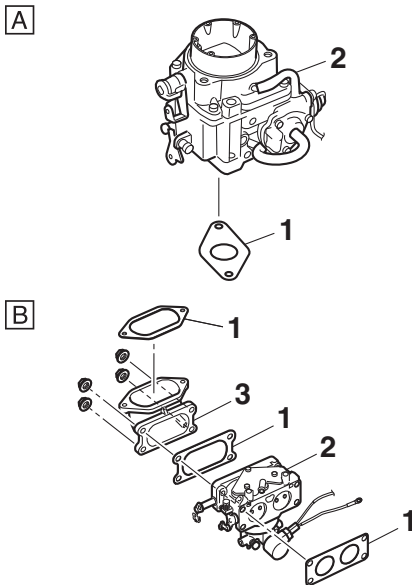

CHECKING THE CARBURETOR

1. Check:
 - Carburetor assembly
Cracks/damage → Replace.
2. Check:
 - Throttle valve operation
Does not move smoothly → Replace.
 - Engine speed
The engine speed cannot be adjusted with "ENGINE SPEED (EH63K/EH64A/EH64K/EH65A/EH65B)" on page 2-15 or "ENGINE SPEED (EH72A/EH72B/EH72K)" on page 2-17 → Replace.

CARBURETOR ASSEMBLY

INSTALLING THE CARBURETOR ASSEMBLY

1. Install:

- Gasket "1" **New**
- Carburetor assembly "2"
- Joint (EH72A/EH72B/EH72K) "3"
- Carburetor assembly bolt (EH63K/EH64A/EH64K/EH65A/EH65B)
- Carburetor assembly nut (EH72A/EH72B/EH72K)

A. EH63K/EH64A/EH64K/EH65A/EH65B

B. EH72A/EH72B/EH72K



**Carburetor assembly bolt (EH63K/EH64A/
EH64K/EH65A/EH65B):**

18 N·m (1.8 kgf·m, 13 lb·ft)

**Carburetor assembly nut (EH72A/EH72B/
EH72K):**

8 N·m (0.8 kgf·m, 5.9 lb·ft)

2. Install:

- Link rod/spring
- Throttle lever assembly
- Governor arm
- Spring "1"

TIP

- Install the long side "a" of the spring to the throttle lever assembly, the short side "b" to the hole "d" position of the governor arm.
- Install the link rod/spring in the hole "c" position of the governor arm.

4

FUEL

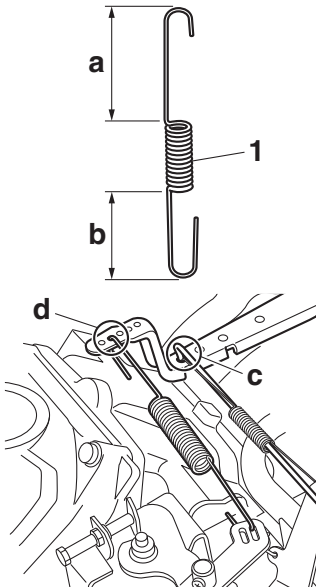
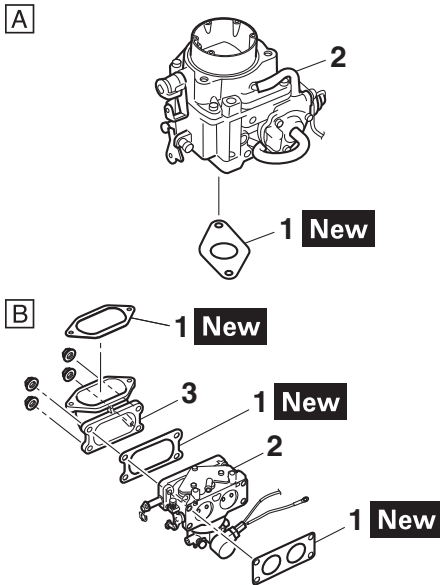

CARBURETOR ASSEMBLY

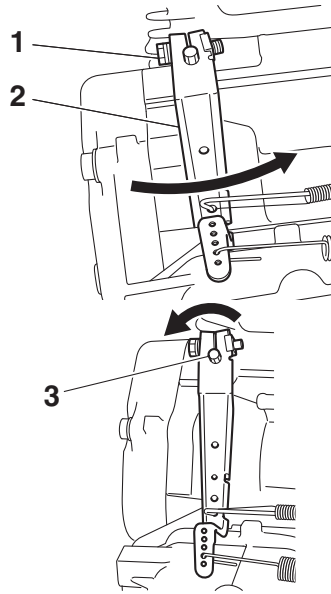

ADJUSTING THE GOVERNOR

1. Adjust:

- Governor

Adjustment steps:

- a. Loosen the governor arm bolt "1".
- b. Turn the governor arm "2" counterclockwise until it stops so that the throttle lever is fully open.
- c. Turn the governor fork "3" counterclockwise until it stops.
- d. Tighten the governor arm bolt "1".



Governor arm bolt:
10 N·m (1.0 kgf·m, 7.4 lb·ft)

INTAKE MANIFOLD

INTAKE MANIFOLD

EH63K/EH64A/EH64K/EH65A/EH65B

4

FUEL

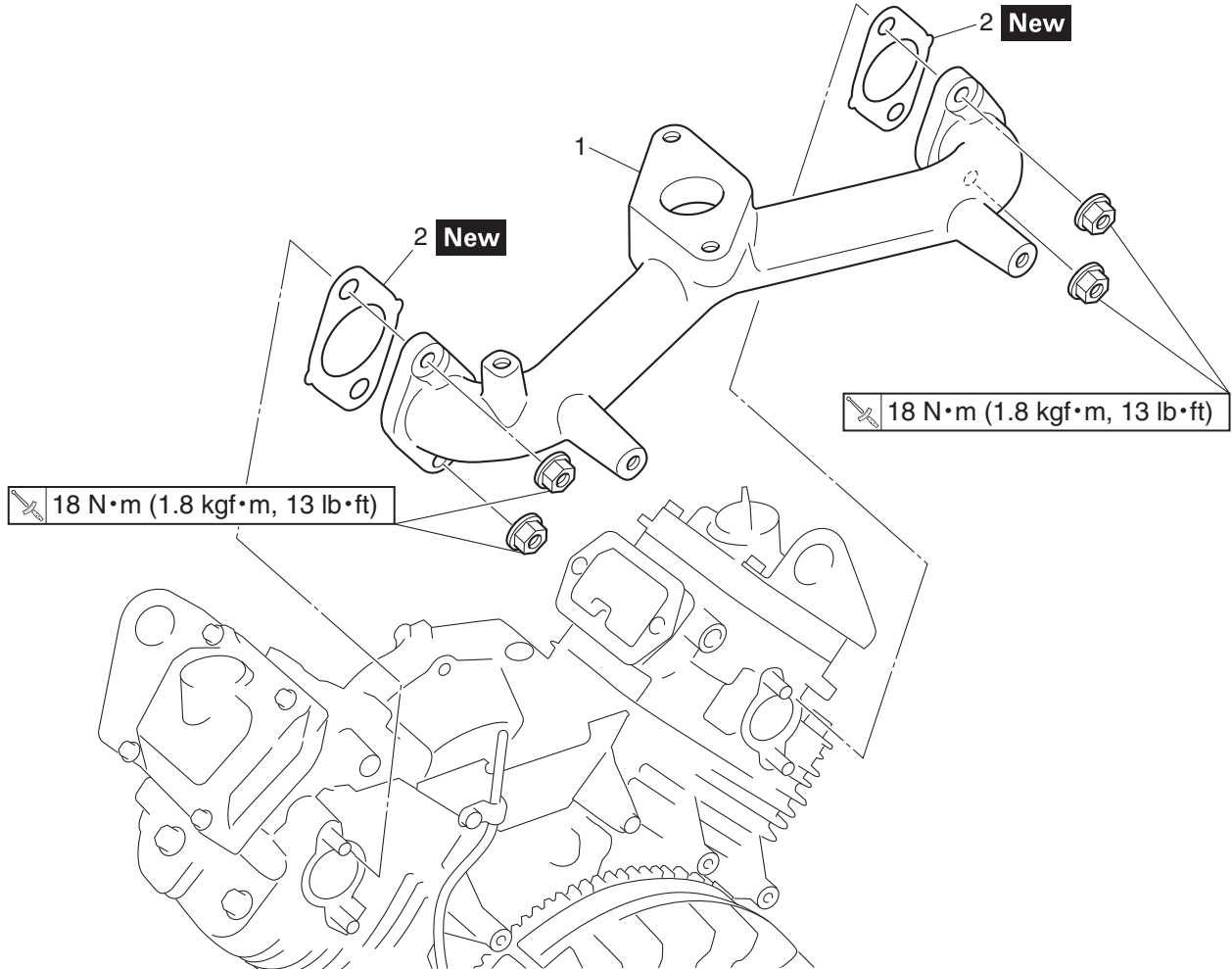

Order	Job/Parts to remove	Q'ty	Remarks
	Removing the intake manifold		Remove the parts in the order listed.
	Muffler		Refer to "MUFFLER" on page 3-5.
	Air filter		Refer to "AIR FILTER" on page 3-3.
	Fan case and fan		Refer to "CASE AND FAN" on page 3-14.
	Rectifier/regulator		Refer to "RECTIFIER/REGULATOR" on page 3-13.
	Fuel pump		Refer to "FUEL PUMP" on page 4-1.
	Cylinder cover		Refer to "CYLINDER COVERS" on page 3-17.
	TCI unit		Refer to "TCI UNITS" on page 3-19.
	Carburetor		Refer to "CARBURETOR ASSEMBLY" on page 4-4.
1	Intake manifold	1	
2	Gasket	2	

INTAKE MANIFOLD

EH72A/EH72B/EH72K

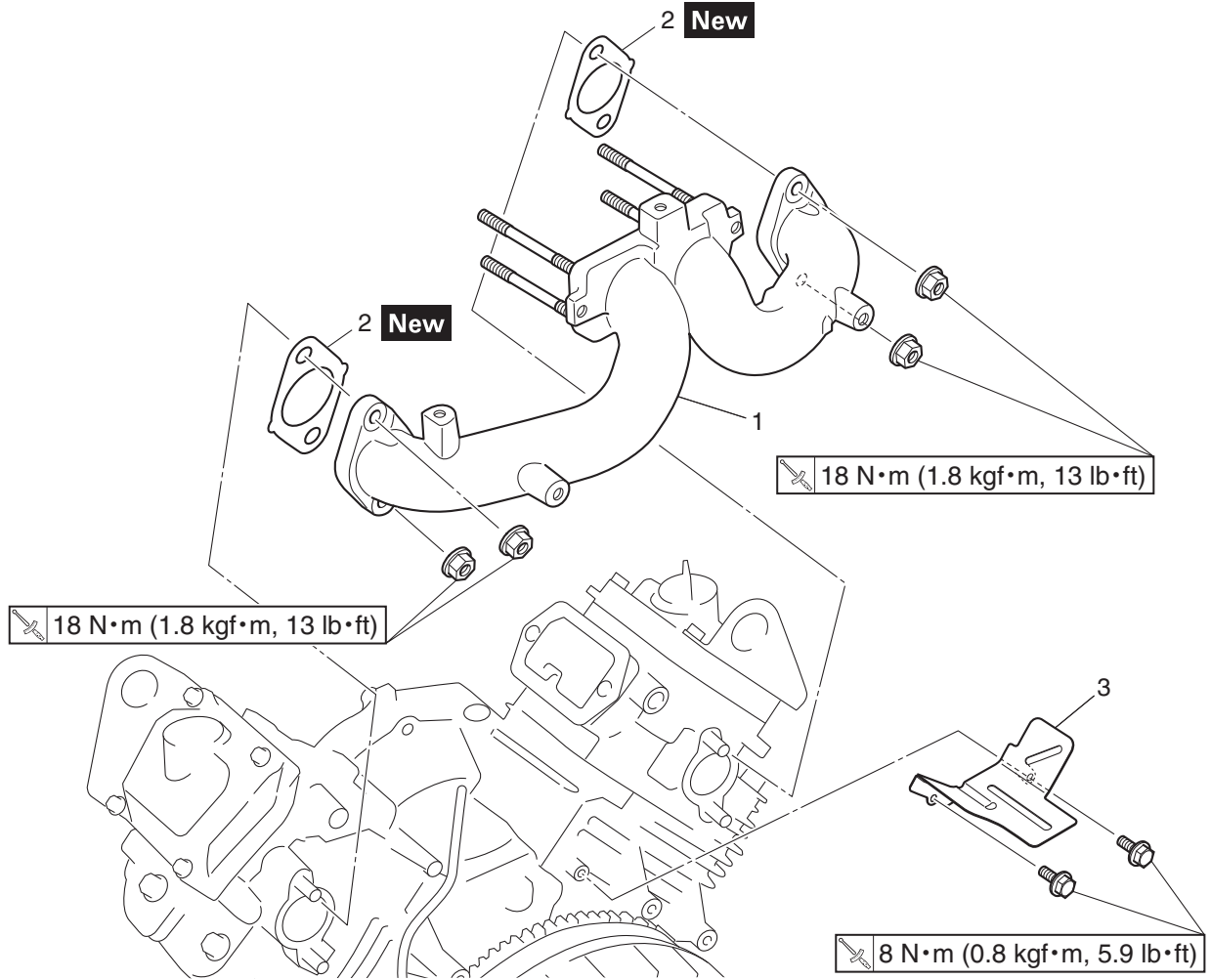

Order	Job/Parts to remove	Q'ty	Remarks
	Removing the intake manifold		Remove the parts in the order listed.
	Muffler		Refer to "MUFFLER" on page 3-5.
	Air filter		Refer to "AIR FILTER" on page 3-3.
	Fan case and fan		Refer to "CASE AND FAN" on page 3-14.
	Rectifier/regulator		Refer to "RECTIFIER/REGULATOR" on page 3-13.
	Fuel pump		Refer to "FUEL PUMP" on page 4-1.
	Cylinder cover		Refer to "CYLINDER COVERS" on page 3-17.
	TCI unit		Refer to "TCI UNITS" on page 3-19.
	Carburetor		Refer to "CARBURETOR ASSEMBLY" on page 4-4.
1	Intake manifold	1	
2	Gasket	2	
3	Bracket	1	

INTAKE MANIFOLD

REMOVING THE INTAKE MANIFOLD

1. Remove:
 - Intake manifold "1"
 - Gasket "2"

- A. EH63K/EH64A/EH64K/EH65A/EH65B
- B. EH72A/EH72B/EH72K

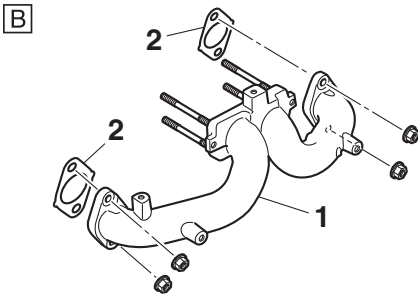
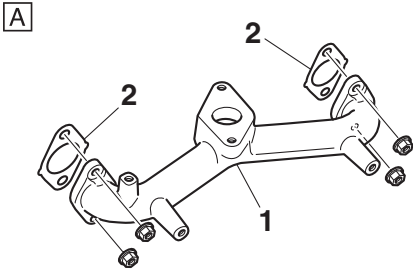

CHECKING THE INTAKE MANIFOLD

1. Check:
 - Intake manifoldCracks/damage → Replace.

INSTALLING THE INTAKE MANIFOLD

1. Install:
 - Gasket "1" **New**
 - Intake manifold "2"

- A. EH63K/EH64A/EH64K/EH65A/EH65B
- B. EH72A/EH72B/EH72K

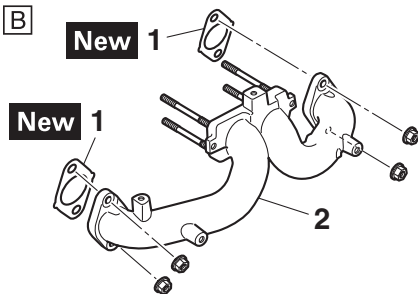
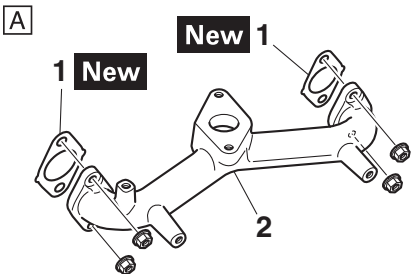

INTAKE MANIFOLD

A

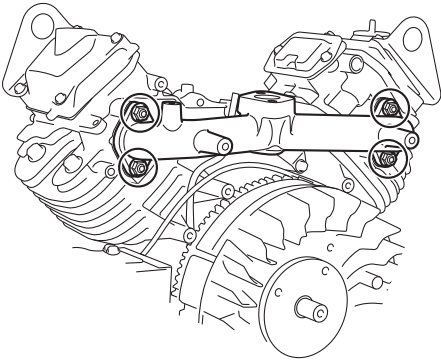

2. Install:
- Intake manifold nut

- A. EH63K/EH64A/EH64K/EH65A/EH65B
- B. EH72A/EH72B/EH72K



Intake manifold nut:
18 N·m (1.8 kgf·m, 13 lb·ft)



B

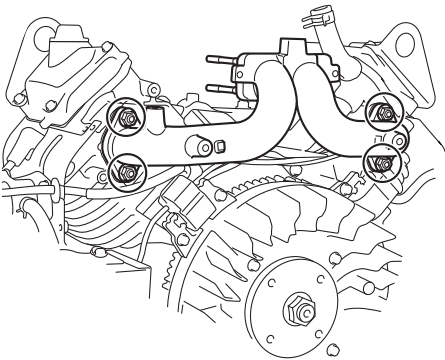

ELECTRICAL

CIRCUIT DIAGRAM

ELECTRICAL 51

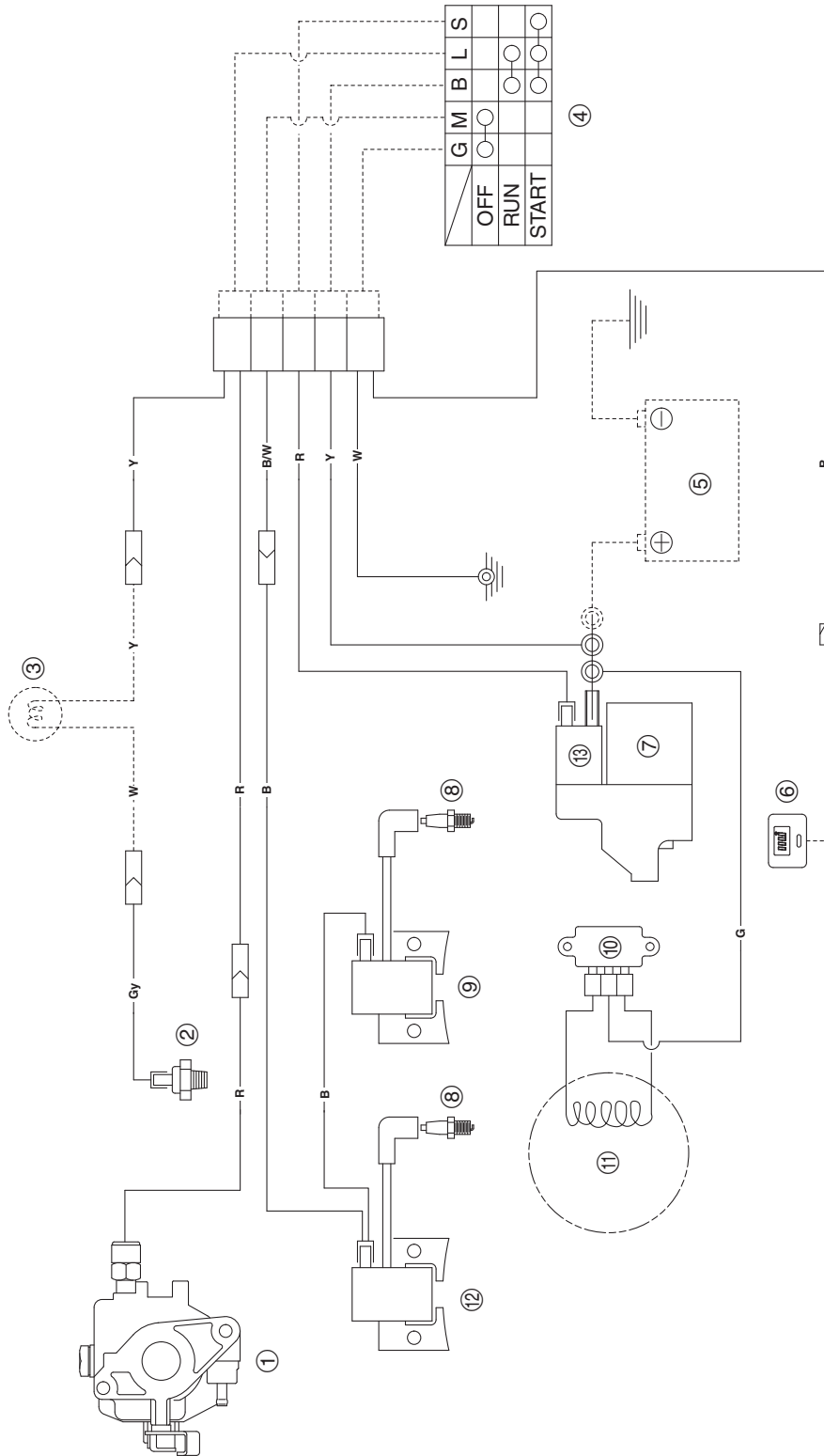

CIRCUIT DIAGRAM

1. Carburetor
2. Oil pressure switch
3. Oil warning light (option)
4. Engine switch (option)
5. Battery (12 V, option)
6. Tachometer/hour meter (option)
7. Starter motor
8. Spark plug
9. TCI unit #1
10. Rectifier/regulator
11. Stator coil assembly
12. TCI unit #2
13. Starter relay

Color code

B	Black	W	White
G	Green	Gy	Gray
R	Red	B/W	Black/White
Y	Yellow		

ELECTRICAL COMPONENTS

ELECTRICAL COMPONENTS

5
ELECTRICAL

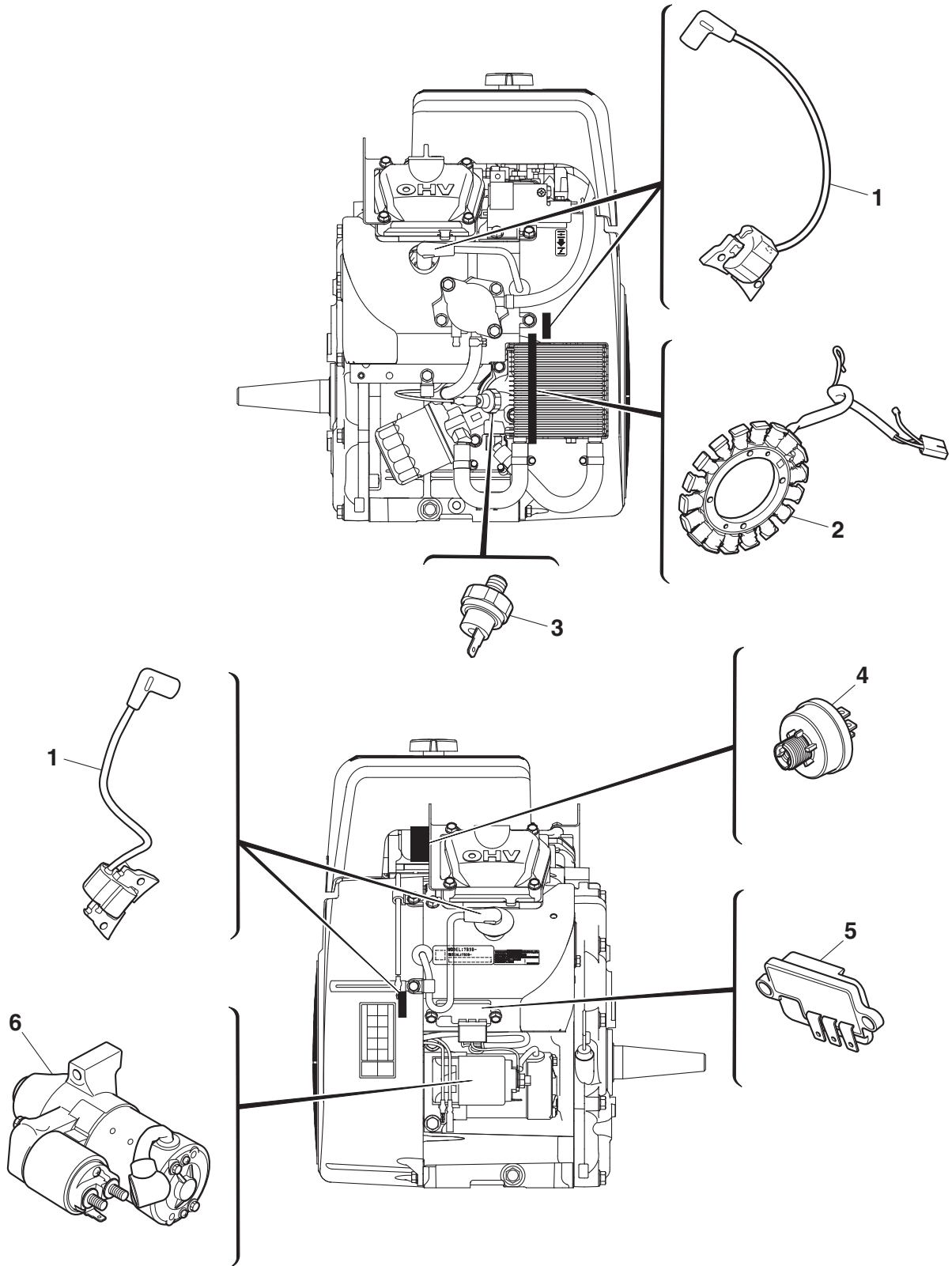

ELECTRICAL COMPONENTS

1. TCI unit
2. Stator coil assembly
3. Oil pressure switch
4. Engine switch (equipped models only)
5. Rectifier/regulator
6. Starter motor

CHECKING THE SWITCH CONTINUITY

Check each switch for continuity with the tester. If the continuity reading is incorrect, check the wiring connections and if necessary, replace the switch.

NOTICE

Never insert the tester probes into the coupler terminal slots. Always insert the probes from the opposite end of the coupler, taking care not to loosen or damage the leads.

	<p>Digital circuit tester (CD732): 90890-03243</p> <p>Model 88 Multimeter with tachometer: YU-A1927</p>
---	---

TIP

- Before checking for continuity, set the digital circuit tester to the “Ω” range.
- When checking for continuity, switch back and forth between the switch positions a few times.

Measurement example of the electric components

A. Connect the connector and check.

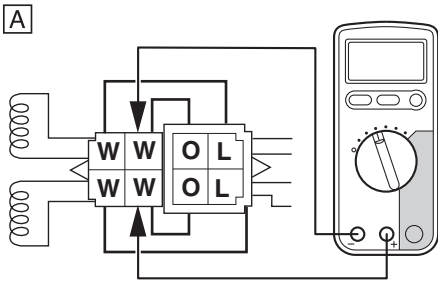

B. Disconnect the connector and check.

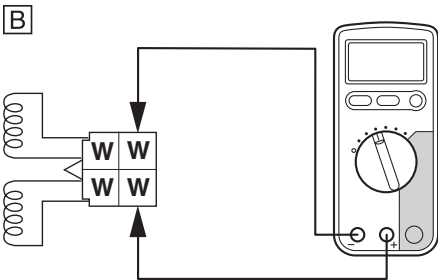

CHECKING THE OIL PRESSURE SWITCH

1. Drain:
 - Engine oil
2. Disconnect:
 - Oil pressure switch lead

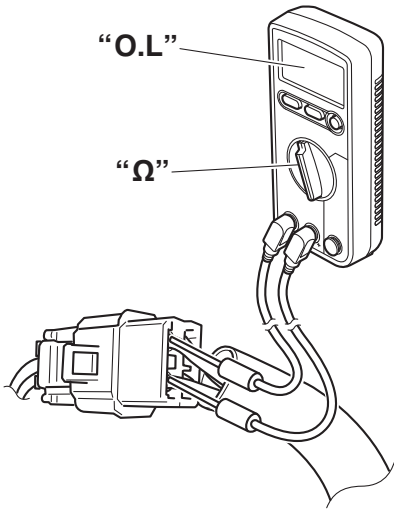

ELECTRICAL COMPONENTS

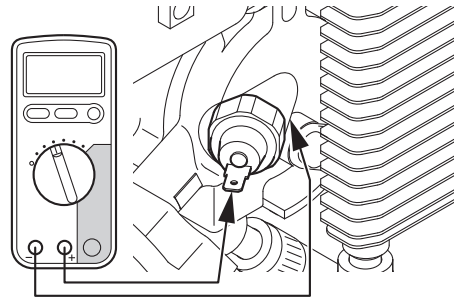

3. Connect:
 - Digital circuit tester
(Connect between the engine body and oil pressure switch terminal.)

	Digital circuit tester (CD732): 90890-03243 Model 88 Multimeter with tachometer: YU-A1927
---	--

4. Check:
 - Oil pressure switch continuity
No continuity → Replace the oil pressure switch.

CHECKING THE IGNITION SPARK GAP

1. Check:
 - Engine oil level
Insufficient → Add the engine oil.
(Refer to “ENGINE OIL LEVEL” on page 2-5.)
2. Check:
 - Spark plug condition
Wear/damage → Replace.
(Refer to “SPARK PLUGS” on page 2-3.)
3. Check:
 - Ignition spark gap
Out of specification → Perform the ignition system troubleshooting, starting with step 6.
(Refer to “ENGINE DOES NOT START” on page 6-1.)

	Minimum ignition spark gap: 6.0 mm (0.2362 in)
---	---

TIP

If the ignition spark gap is within the specification, the ignition system circuit is operating normally.

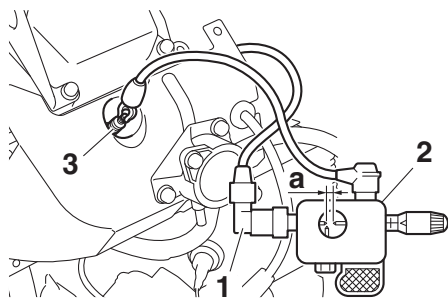

- a. Disconnect the spark plug cap “1” from the spark plug.
- b. Connect the ignition checker “2” as shown.
- c. Connect the ignition checker lead to the spark plug “3” as shown.

	Ignition checker: 90890-06754 Oppama pet-4000 spark checker: YM-34487
---	--

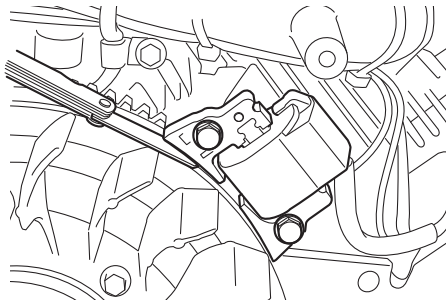

- d. Set the engine switch to “RUN”.
- e. Measure the ignition spark gap “a”.

CHECKING THE AIR GAP

1. Check:
 - Measure the gap between the flywheel and TCI unit.
 Out of specification → Adjust the TCI unit.
 (Refer to “INSTALLING THE TCI UNITS” on page 3-23.)

	TCI unit air gap: 0.3–0.5 mm (0.011–0.019 in)
---	--

CHECKING THE IGNITION COIL (TCI UNIT, PRIMARY) RESISTANCE

1. Check:
 - Primary coil resistance
 Out of specification → Replace.

	Primary coil resistance: 0–5 Ω
---	---

- a. Remove the ignition coil (TCI unit).
- b. Connect the digital circuit tester (Ω) to the primary terminal.

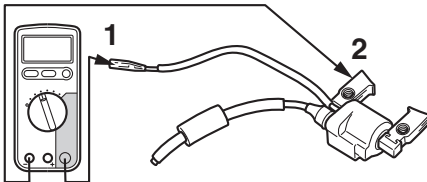

	Digital circuit tester (CD732): 90890-03243 Model 88 Multimeter with tachometer: YU-A1927
---	--

- | |
|---|
| <ul style="list-style-type: none"> • Positive tester probe → Wire “1” • Negative tester probe → Body ground “2” |
|---|

- c. Measure the primary coil resistance.

CHECKING THE IGNITION COIL (TCI UNIT, SECONDARY) RESISTANCE

1. Check:
 - Secondary coil resistance
 Out of specification → Replace.

	Secondary coil resistance: 8–16 kΩ
---	---

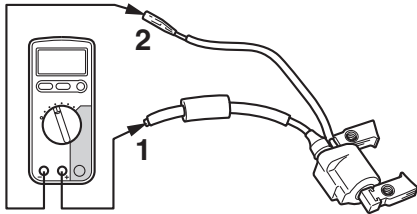

- a. Remove the ignition coil (TCI unit).
- b. Connect the digital circuit tester (Ω) to the secondary terminal.

	Digital circuit tester (CD732): 90890-03243 Model 88 Multimeter with tachometer: YU-A1927
---	--

- | |
|---|
| <ul style="list-style-type: none"> • Positive tester probe → High tension cord "1" • Negative tester probe → Wire "2" |
|---|

- c. Measure the secondary coil resistance.

CHECKING THE ENGINE SWITCH (EQUIPPED MODELS ONLY)

1. Check:

- Engine switch continuity
Out of specification → Replace.

- a. Disconnect the engine switch connectors.
- b. Connect the digital circuit tester (Ω) to the engine switch connectors as shown.

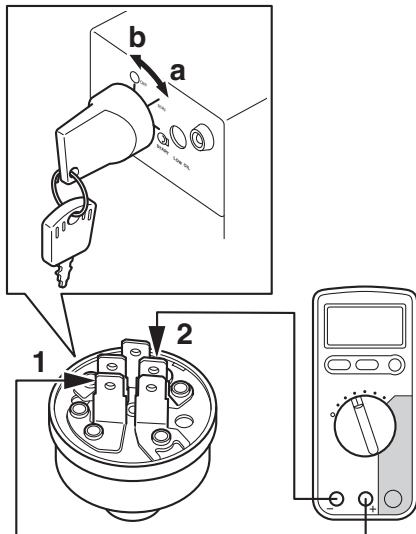

	Digital circuit tester (CD732): 90890-03243 Model 88 Multimeter with tachometer: YU-A1927
---	--

- | |
|--|
| <ul style="list-style-type: none"> • Positive tester probe → Terminal "1" • Negative tester probe → Terminal "2" |
|--|

- c. Check the engine switch continuity.

- | |
|---|
| <ul style="list-style-type: none"> • Engine switch "RUN" → Continuity "a" • Engine switch "OFF" → No continuity "b" |
|---|

CHECKING THE STARTER MOTOR OPERATION

1. Remove:

- Starter motor

2. Check:

- Starter motor operation

ELECTRICAL COMPONENTS

Does not operate → Perform the electric starting system troubleshooting, starting with step 3. (Refer to “ELECTRIC STARTING SYSTEM” on page 6-2.)

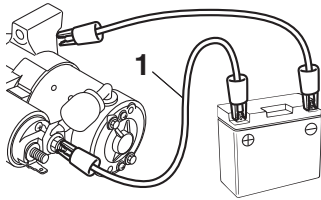

- a. Prepare the battery and jumper lead, connect the jumper lead “1” to the (+) side of the battery and the starter motor terminal as shown in the illustration, and ground the (-) side of the battery to the main body of the starter motor.
- b. Check the starter motor operation.

⚠ WARNING

- The wire to be used as the jumper lead must have a capacity equal to or greater than that of battery lead. Otherwise, there is a possibility that the jumper lead will burn.
- This check is likely to produce sparks, so be sure that no flammable gas or fluid is in the vicinity.

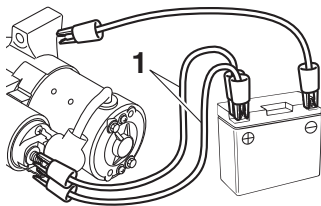

- c. Connect the jumper lead “1” to the (+) side of the battery and the starter relay terminal as shown in the illustration, and ground the (-) side of the battery to the main body of the starter motor.
- d. Check the starter motor operation.

CHECKING THE WIRE HARNESS

1. Check:
 - Connector terminal
Dirt, corrosion or poor connection → Clean or replace the connector.

ELECTRIC STARTING SYSTEM

ELECTRIC STARTING SYSTEM

REMOVING THE STARTER MOTOR

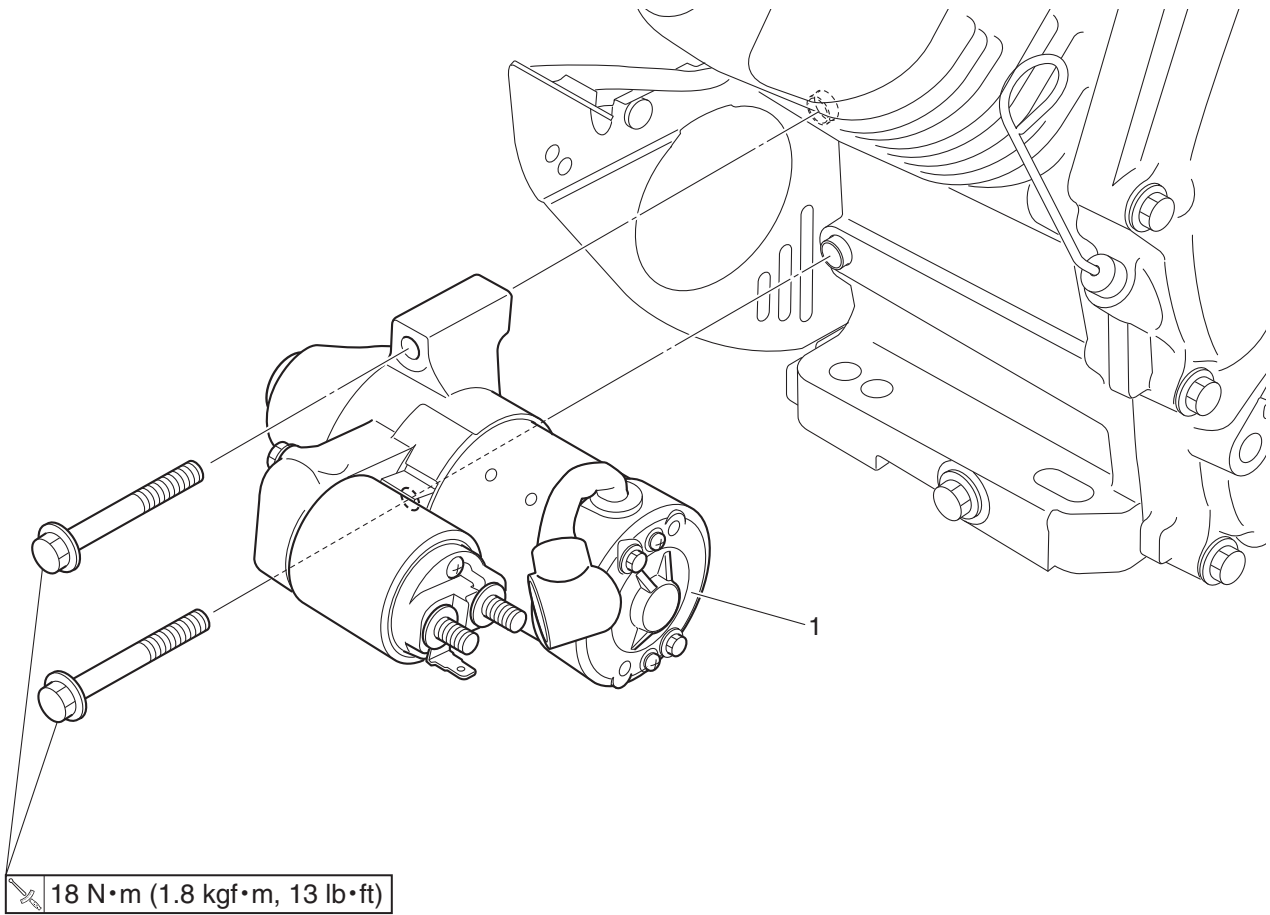

Order	Job/Parts to remove	Q'ty	Remarks
	Removing the starter motor		Remove the parts in the order listed.
	Rectifier/regulator		Refer to "RECTIFIER/REGULATOR" on page 3-13.
	Cylinder cover		Refer to "CYLINDER COVERS" on page 3-17.
1	Starter motor assembly	1	

CHARGING SYSTEM

CHECKING THE STATOR COIL ASSEMBLY

1. Remove:
 - Stator coil assembly
(Refer to “FLYWHEEL AND STATOR COIL ASSEMBLY” on page 3-20.)
2. Check:
 - Stator coil assembly resistance
Out of specification → Replace.

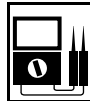

Stator coil assembly resistance:
0.2 Ω \pm 20 % at 20 °C (68 °F)

- a. Connect the digital circuit tester (Ω) to the stator coil assembly.



Digital circuit tester (CD732):
90890-03243
Model 88 Multimeter with tachometer:
YU-A1927

- Positive tester probe →
Connector terminal
- Negative tester probe →
Connector terminal

- b. Measure the stator coil assembly resistance.

CHECKING THE RECTIFIER/REGULATOR

1. Remove:
 - Rectifier/regulator
(Refer to “RECTIFIER/REGULATOR” on page 3-13.)

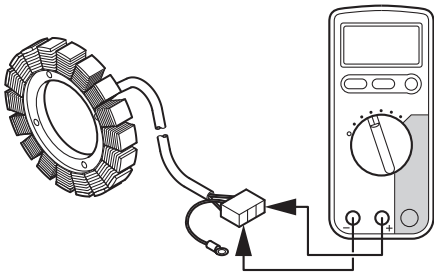

CHARGING SYSTEM

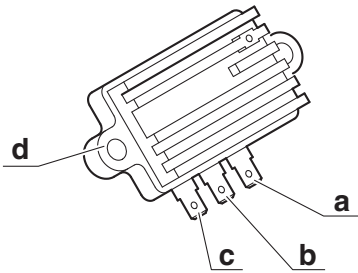

- 2.** Check:
- Rectifier/regulator resistance
Out of specification → Replace.

TIP

- Measure the resistance value between terminals a–d.
- Refer to the table for the resistance value between terminals.

- A. Negative terminal
- B. Positive terminal

		A			
		a	b	c	d
B	a		200–300 Ω	200–300 Ω	O.L
	b	O.L		0 Ω	O.L
	c	O.L	0 Ω		O.L
	d	O.L	50 Ω	50 Ω	



Digital circuit tester (CD732):
90890-03243

Model 88 Multimeter with tachometer:
YU-A1927

MEMO

TROUBLESHOOTING

ENGINE DOES NOT START

No.	Checking steps	Possible remedy
1	Check the engine oil level. (Refer to "ENGINE OIL LEVEL" on page 2-5.)	Add the oil if it is insufficient.
2	Check the fuel level.	Add the fuel if it is insufficient.
3	Check if the fuel has deteriorated.	Replace the fuel.
4	Check the spark plugs. (Refer to "SPARK PLUGS" on page 2-3.)	Re-gap or replace the spark plug.
5	Check the ignition spark gap. (Refer to "CHECKING THE IGNITION SPARK GAP" on page 5-6.)	If the ignition spark gap is OK, the ignition system is OK.
6	Check the ignition coil. (Refer to "CHECKING THE IGNITION COIL (TCI UNIT, PRIMARY) RESISTANCE" on page 5-7.)	Replace the ignition coil.
7	Check the carburetor for clogged passages or fuel overflow.	Clean.
8	Check the compression pressure. (Refer to "MEASURING THE COMPRESSION PRESSURE" on page 3-1.)	Too high: Decarbonize the combustion chamber if there is carbon deposits. Too low: Next checking steps.
9	Measure the valve clearance. (Refer to "ADJUSTING THE VALVE CLEARANCE" on page 2-13.)	Adjust the valve clearance.
10	Check the valve face and valve seat for wear. (Refer to "VALVES" on page 3-34.)	Resurface or replace the valve face and valve seat.
11	Check if the marks on the crankshaft and camshaft are aligned. (Refer to "INSTALLING THE VALVE LIFTERS AND CAMSHAFT" on page 3-53.)	Correct.
12	Check if there is seizure, wear, or damage on the piston, piston ring, or cylinder. (Refer to "PISTONS, CAMSHAFT, CRANKCASE, AND CRANKSHAFT" on page 3-44.)	Rebore or replace.

ELECTRIC STARTING SYSTEM

ELECTRIC STARTING SYSTEM

No.	Checking steps	Possible remedy
1	Check the battery (option).	<ul style="list-style-type: none"> • Clean the battery terminals. • Recharge or replace the battery.
2	Check the starter motor operation. (Refer to "CHECKING THE STARTER MOTOR OPERATION" on page 5-8.)	If the starter motor operates normally, the starter motor is OK.
3	Check the engine switch (equipped models only).	Replace the engine switch.
4	Check the starting system wiring. (Refer to "CIRCUIT DIAGRAM" on page 5-1.)	Properly connect or repair the starting system's wiring.
5	The starting system circuit is OK.	—

6

TROUBLESHOOTING

ENGINE STARTS BUT STALLS

No.	Checking steps	Possible remedy
1	Check the fuel level.	Add the fuel if it is insufficient.
2	Check if the fuel hoses are clogged.	Clean.
3	Check if there is air suction from the carburetor joint, gasket, or throttle shaft.	<ul style="list-style-type: none"> • Tighten the carburetor nuts securely. • Replace the carburetor joint or gasket with a new one.
4	Check the compression pressure. (Refer to "MEASURING THE COMPRESSION PRESSURE" on page 3-1.)	Too high: Decarbonize the combustion chamber if there is carbon deposits. Too low: Next checking steps.
5	Measure the valve clearance. (Refer to "ADJUSTING THE VALVE CLEARANCE" on page 2-13.)	Adjust the valve clearance.
6	Check if there is seizure, wear, or damage on the piston, piston ring, or cylinder. (Refer to "PISTONS, CAMSHAFT, CRANKCASE, AND CRANKSHAFT" on page 3-44.)	Rebore or replace.
7	Check the TCI unit air gap.	Adjust.

ENGINE SPEED DOES NOT INCREASE

ENGINE SPEED DOES NOT INCREASE

No.	Checking steps	Possible remedy
1	Check the spark plug for dirt and check the spark plug gap.	Clean, adjust, or replace the spark plug.
2	Check the air filter element for dirt.	Clean.
3	Check the compression pressure. (Refer to "MEASURING THE COMPRESSION PRESSURE" on page 3-1.)	Too high: Decarbonize the combustion chamber if there is carbon deposits. Too low: Next checking steps.
4	Measure the valve clearance. (Refer to "ADJUSTING THE VALVE CLEARANCE" on page 2-13.)	Adjust the valve clearance.
5	Check the valve face and valve seat for wear. (Refer to "VALVES" on page 3-34.)	Resurface or replace the valve face and valve seat.
6	Check if the marks on the crankshaft and camshaft are aligned. (Refer to "INSTALLING THE VALVE LIFTERS AND CAMSHAFT" on page 3-53.)	Correct.
7	Check if there is seizure, wear, or damage on the piston, piston ring, or cylinder. (Refer to "PISTONS, CAMSHAFT, CRANKCASE, AND CRANKSHAFT" on page 3-44.)	Rebore or replace.
8	Check if the main passages, such as the main jet in the carburetor, are clogged.	Clean the parts.
9	Check if there is air suction from the carburetor joint, gasket, or throttle shaft.	<ul style="list-style-type: none">• Tighten the carburetor nuts securely.• Replace the carburetor joint or gasket with a new one.

ENGINE SPEED IS UNEVEN

ENGINE SPEED IS UNEVEN

No.	Checking steps	Possible remedy
1	Check the fuel level.	Add the fuel if it is insufficient.
2	Check if the fuel has deteriorated.	Replace the fuel.
3	Check the spark plug for dirt and check the spark plug gap.	Clean, adjust, or replace the spark plug.
4	Check the carburetor turn out and float height.	Adjust or replace.
5	Check if there is air suction from the carburetor joint, gasket, or throttle shaft.	<ul style="list-style-type: none"> • Tighten the carburetor nuts securely. • Replace the carburetor joint or gasket with a new one.
6	Check if the slow or main passages, such as the main jet in the carburetor, are clogged.	Clean the parts.
7	Measure the valve clearance. (Refer to "ADJUSTING THE VALVE CLEARANCE" on page 2-13.)	Adjust the valve clearance.
8	Check the valve face and valve seat for wear. (Refer to "VALVES" on page 3-34.)	Resurface or replace the valve face and valve seat.
9	Check if there is seizure, wear, or damage on the piston, piston ring, or cylinder. (Refer to "PISTONS, CAMSHAFT, CRANKCASE, AND CRANKSHAFT" on page 3-44.)	Rebore or replace.

THE BATTERY (OPTION) IS NOT CHARGED

No.	Checking steps	Possible remedy
1	Check the battery (option).	<ul style="list-style-type: none"> • Clean the battery terminals. • Recharge or replace the battery.
2	Check the stator coil assembly. (Refer to "CHECKING THE STATOR COIL ASSEMBLY" on page 5-11.)	Replace the stator coil assembly.
3	Check the rectifier/regulator. (Refer to "CHECKING THE RECTIFIER/REGULATOR" on page 5-11.)	Replace the rectifier/regulator.
4	Check the entire charging system's wiring. (Refer to "CIRCUIT DIAGRAM" on page 5-1.)	Properly connect or repair the charging system's wiring.
5	The charging system circuit is OK.	—

GOVERNOR OPERATION

GOVERNOR OPERATION

No.	Checking steps	Possible remedy
1	Check that the governor link operate smoothly.	Adjust or replace.
2	Check that the governor spring is stretched.	Replace.
3	Check the governor adjustment. (Refer to "ADJUSTING THE GOVERNOR" on page 4-13.)	Adjust.
4	Check the governor weight and governor bushing function. (Refer to "CHECKING THE FLYWEIGHT SHAFT ASSEMBLY" on page 3-49.)	Adjust or replace.

MEMO

SPECIFICATIONS

GENERAL SPECIFICATIONS

Model:

EH63K
EH64K
EH64A
EH65B
EH65A
EH72A
EH72B
EH72K

Model code:

7D3B00 (EH63K)
7D4B00 (EH64K)
7D4J00 (EH64A)
7D5200 (EH65B)
7D5J00 (EH65A)
7B3100 (EH72A)
7B3201 (EH72B)
7B3B00 (EH72K)

Dimensions:

Overall length	317 mm (12.48 in)
Overall width	477 mm (18.77 in)
Overall height	475 mm (18.70 in)
Dry weight	44 kg (97.00 lb) (EH63K/EH64K/EH64A/EH65B/EH65A) 46 kg (101.41 lb) (EH72A/EH72B/EH72K)

Engine:

Engine type	Air-cooled 4-cycle V type 2-cylinder OHV gasoline engine
Cylinder arrangement	2
Displacement	0.653 L (653 cm ³) (EH63K/EH64K/EH64A/EH65B/EH65A) 0.720 L (720 cm ³) (EH72A/EH72B/EH72K)
Bore × Stroke	80.0 × 65.0 mm (3.1496 × 2.5590 in) (EH63K/EH64K/ EH64A/EH65B/EH65A) 84.0 × 65.0 mm (3.3070 × 2.5590 in) (EH72A/EH72B/ EH72K)
Compression ratio	8.3
Standard compression pressure	1200 kPa (12 kg/cm ² , 174 psi)
Net output*	10.8 kW (14.5 PS) (EH63K) 11.9 kW (16.0 PS) (EH64K/EH64A) 12.7 kW (17.0 PS) (EH65B/EH65A) 13.4 kW (18.0 PS) (EH72A/EH72B/EH72K)
Fuel	Unleaded gasoline
Fuel tank capacity	—

GENERAL SPECIFICATIONS

Engine oil quantity	1.55 L (1.64 US qt, 1.36 Imp.qt) (including in oil filter)
Recommended oil brand	YAMALUBE
Available oil grade	API SE type or higher JASO MA or MB
Available viscosity index	10W-30 or 10W-40
Oil filter type	Cartridge type
Lubrication system	Forced pressure feeding type
Air filter system	Semi-wet/dry type
Cooling system	Air cooled
Starting system	Starter motor
Stopping system	Misfire
Rotating direction	Counterclockwise rotation (as seen from the output shaft side)
Governor type	Centrifugal weight system

7

SPECIFICATIONS

Electrical:

Ignition system	TCI
Ignition timing (3600 r/min)	BTDC $26.5 \pm 2^\circ/3600$ r/min
Spark plug type	BPR5ES (NGK) (Except for EH64A) BPR4EY (NGK) (EH64A)
Spark plug gap	0.7–0.8 mm (0.028–0.031 in) (Except for EH64A) 0.6–0.7 mm (0.024–0.028 in) (EH64A)
Solenoid valve resistance	34.2–41.8 Ω at 20 °C (68 °F)

* The power rating of the engine indicated in the SPECIFICATIONS is the net power output tested on an engine model and measured at 3600 r/min.

Actual power output for an installed engine will vary depending on numerous factors, including the operating speed of the engine, environmental conditions, and other variables.

NOTICE

Use only unleaded gasoline. The use of leaded gasoline will cause severe damage to internal engine parts.

MAINTENANCE SPECIFICATIONS

MAINTENANCE SPECIFICATIONS

ENGINE

Piston:

Piston-to-cylinder clearance	0.012–0.051 mm (0.0004–0.0020 in) (EH63K/EH64K/ EH64A/EH65B/EH65A) 0–0.042 mm (0–0.0016 in) (EH72A/EH72B/EH72K)
Limit	0.15 mm (0.0059 in)
Piston diameter	79.960–79.980 mm (3.1480–3.1488 in) (EH63K/EH64K/ EH64A/EH65B/EH65A) 83.980–84.000 mm (3.3062–3.3070 in) (EH72A/EH72B/ EH72K)
Limit	79.878 mm (3.1447 in) (EH63K/EH64K/EH64A/EH65B/ EH65A) 83.890 mm (3.3027 in) (EH72A/EH72B/EH72K)
Measuring point (from piston skirt bottom)	13.0 mm (0.5118 in) (EH63K/EH64K/EH64A/EH65B/ EH65A) 10.0 mm (0.3937 in) (EH72A/EH72B/EH72K)
Piston pin hole inside diameter	21.002–21.011 mm (0.8268–0.8272 in)
Limit	21.041 mm (0.8283 in)

Piston pin:

Piston pin diameter	20.989–21.002 mm (0.8263–0.8268 in)
Limit	20.969 mm (0.8255 in)

Piston ring:

Top ring	
Type	Barrel
Dimensions	1.5 × 3.4 mm (0.0590 × 0.1338 in) (EH63K/EH64K/ EH64A/EH65B/EH65A) 1.5 × 3.6 mm (0.0590 × 0.1417 in) (EH72A/EH72B/ EH72K)
End gap (installed)	0.20–0.40 mm (0.0079–0.0157 in)
Limit	1.50 mm (0.0590 in)
Side clearance	0.05–0.09 mm (0.0019–0.0035 in)
Limit	0.14 mm (0.0055 in)
2nd ring	
Type	Taper
Dimensions	1.5 × 3.4 mm (0.0590 × 0.1338 in) (EH63K/EH64K/ EH64A/EH65B/EH65A) 1.5 × 3.6 mm (0.0590 × 0.1417 in) (EH72A/EH72B/ EH72K)
End gap (installed)	0.20–0.40 mm (0.0079–0.0157 in)
Limit	1.50 mm (0.0590 in)
Side clearance	0.03–0.07 mm (0.0012–0.0028 in)
Limit	0.13 mm (0.0051 in)

MAINTENANCE SPECIFICATIONS

Oil ring	
Type	Combination
Dimensions	2.8 × 3.0 mm (0.1102 × 0.1181 in) (EH63K/EH64K/ EH64A/EH65B/EH65A) 3.0 × 3.2 mm (0.1181 × 0.1259 in) (EH72A/EH72B/ EH72K)
End gap (installed)	0.20–0.70 mm (0.0079–0.0276 in)
Limit	1.50 mm (0.0590 in)

Cylinder head:

Warpage limit	0.1 mm (0.0039 in)
---------------	--------------------

Cylinder:

Bore	80.000–80.019 mm (3.1496–3.1503 in) (EH63K/EH64K/ EH64A/EH65B/EH65A) 84.000–84.022 mm (3.3070–3.3079 in) (EH72A/EH72B/ EH72K)
Warpage limit	0.1 mm (0.0039 in)

Crankshaft:

Big end side clearance	0.1–0.4 mm (0.0039–0.0157 in)
Crank pin outside diameter	38.956–38.970 mm (1.5336–1.5342 in)
Limit	38.900 mm (1.5314 in)

Connecting rod:

Small end diameter	21.010–21.023 mm (0.8271–0.8276 in)
Big end diameter	39.000–39.010 mm (1.5354–1.5358 in)

Camshaft:

Camshaft lobe dimensions	
Lobe height (Intake)	35.26–35.46 mm (1.3881–1.3960 in) (EH63K/EH64K/ EH64A/EH65B/EH65A) 35.56–35.76 mm (1.3999–1.4078 in) (EH72A/EH72B/ EH72K)
Limit	35.16 mm (1.3842 in) (EH63K/EH64K/EH64A/EH65B/ EH65A) 35.46 mm (1.3960 in) (EH72A/EH72B/EH72K)
Lobe height (Exhaust)	35.26–35.46 mm (1.3881–1.3960 in) (EH63K/EH64K/ EH64A/EH65B/EH65A) 35.88–36.08 mm (1.4125–1.4204 in) (EH72A/EH72B/ EH72K)
Limit	35.16 mm (1.3842 in) (EH63K/EH64K/EH64A/EH65B/ EH65A) 35.78 mm (1.4086 in) (EH72A/EH72B/EH72K)
Camshaft journal diameter	19.967–19.980 mm (0.7861–0.7866 in)
Limit	19.950 mm (0.0785 in)

MAINTENANCE SPECIFICATIONS

Valve:

Valve dimensions

Valve head diameter (Intake)	34.99–35.01 mm (1.3775–1.3783 in)
Valve head diameter (Exhaust)	30.9–31.1 mm (1.2165–1.2244 in)
Valve stem diameter (Intake)	5.970–5.985 mm (0.2350–0.2356 in)
Valve stem diameter (Exhaust)	5.970–5.985 mm (0.2350–0.2356 in)
Limit (Intake)	5.940 mm (0.2338 in)
Limit (Exhaust)	5.940 mm (0.2338 in)
Valve stem length (Intake)	79.8 mm (3.1417 in)
Valve stem length (Exhaust)	80.3 mm (3.1614 in)
Valve face contact width (Intake)	0.7–1.0 mm (0.0275–0.0393 in)
Valve face contact width (Exhaust)	0.7–1.0 mm (0.0275–0.0393 in)
Limit (Intake)	2.0 mm (0.0787 in)
Limit (Exhaust)	2.0 mm (0.0787 in)
Valve seat contact width (Intake)	0.7–1.0 mm (0.0275–0.0393 in)
Valve seat contact width (Exhaust)	0.7–1.0 mm (0.0275–0.0393 in)
Limit (Intake)	2.0 mm (0.0787 in)
Limit (Exhaust)	2.0 mm (0.0787 in)
Valve stem runout limit	0.01 mm (0.0004 in)

Valve guide:

Valve guide inside diameter (Intake)	6.035–6.053 mm (0.2375–0.2383 in)
Valve guide inside diameter (Exhaust)	6.035–6.053 mm (0.2375–0.2383 in)
Stem to guide clearance (Intake)	0.050–0.083 mm (0.0019–0.0032 in)
Stem to guide clearance (Exhaust)	0.050–0.083 mm (0.0019–0.0032 in)
Valve clearance (cold) (Intake)	0.07–0.13 mm (0.0027–0.0051 in)
Valve clearance (cold) (Exhaust)	0.07–0.13 mm (0.0027–0.0051 in)

Valve spring:

Valve spring free length (Intake)	36.5 mm (1.4370 in)
Valve spring free length (Exhaust)	36.5 mm (1.4370 in)
Limit (Intake)	34.67 mm (1.3649 in)
Limit (Exhaust)	34.67 mm (1.3649 in)

Fuel pump:

Pump type	Diaphragm type
-----------	----------------

MAINTENANCE SPECIFICATIONS

Oil pump:

Inner-rotor-to-outer-rotor-tip clearance	0.15 mm (0.0059 in)
Relief valve operating pressure	373 kPa (3.73 kgf/cm ² , 54.09 psi)

Carburetor:

Type	7D3B (EH63K) 7D4B (EH64K) 7D4J (EH64A) 7D52 (EH65B) 7D5J (EH65A) 7B31 (EH72A) 7B32 (EH72B) 7B3B (EH72K)
I.D. mark	7D3-14101-01 (EH63K) 7D4-14101-01 (EH64K) 7D4-14101-11 (EH64A) 7D5-14101-01 (EH65B) 7D5-14101-11 (EH65A) 7B3-1410101 (EH72A/EH72B/EH72K)
Bore size	ø27 (EH63K/EH64K/EH64A/EH65B/EH65A) ø28 (EH72A/EH72B/EH72K)
Main jet	#132 (EH63K/EH64K/EH64A/EH65B/EH65A) #132 (L)/#133 (R) (EH72A/EH72B/EH72K)
Main nozzle	ø2.8 (EH63K/EH64K/EH64A/EH65B/EH65A) ø3.0 (EH72A/EH72B/EH72K)
Float height	12 mm (0.472 in) (EH63K/EH64K/EH64A/EH65B/EH65A) 3.5 mm (0.14 in) (EH72A/EH72B/EH72K)

Governor arm:

Tension spring attach hole position	2
-------------------------------------	---

Engine speed:

High engine speed	3200–3400 r/min (EH63K/EH64K/EH64A/EH65B/EH65A) 3100–3300 r/min (EH72A/EH72B/EH72K)
Low engine speed	1500–1700 r/min (EH63K/EH64K/EH64A/EH65B/EH65A) 1900–2100 r/min (EH72A/EH72B/EH72K)

MAINTENANCE SPECIFICATIONS

ELECTRICAL

Ignition system:

Ignition system	TCI
Ignition timing at 3600 r/min	BTDC $26.5 \pm 2^\circ$

Ignition coil:

Primary coil resistance	0–5 Ω
Secondary coil resistance	8–16 k Ω
TCI unit air gap	0.3–0.5 mm (0.011–0.019 in)
Minimum ignition spark gap	6.0 mm (0.2362 in)

Charging system:

Stator coil assembly resistance	0.2 $\Omega \pm 20\%$ at 20 °C (68 °F)
---------------------------------	--

Rectifier/regulator:

Regulator type	Single phase full-wave rectification
Voltage	13.8–14.3 V

Oil pressure switch:

Resistance (when engine is stopped)	0 Ω
-------------------------------------	------------

TIGHTENING TORQUES

TIGHTENING TORQUES

Item	Thread size	Tightening torque
Air filter plate bolt	M6 × 1.0	8 N·m (0.8 kgf·m, 5.9 lb·ft)
Intake manifold nut	M8 × 1.25	18 N·m (1.8 kgf·m, 13 lb·ft)
Muffler bracket bolt	M6 × 1.0	18 N·m (1.8 kgf·m, 13 lb·ft)
Muffler nut	M8 × 1.25	18 N·m (1.8 kgf·m, 13 lb·ft)
Muffler cover bolt (EH65A/EH72A)	M6 × 1.0	8 N·m (0.8 kgf·m, 5.9 lb·ft)
Fan case bolt (front)	M6 × 1.0	4.5 N·m (0.45 kgf·m, 3.3 lb·ft)
Fan case bolt (side)	M6 × 1.0	2.5 N·m (0.25 kgf·m, 1.8 lb·ft)
Cylinder cover 1 bolt	M6 × 1.0	13 N·m (1.3 kgf·m, 9.6 lb·ft)
Cylinder cover 2 bolt	M6 × 1.0	8 N·m (0.8 kgf·m, 5.9 lb·ft)
Cylinder cover 3 bolt	M6 × 1.0	8 N·m (0.8 kgf·m, 5.9 lb·ft)
Bracket bolt	M6 × 1.0	8 N·m (0.8 kgf·m, 5.9 lb·ft)
Fan bolt	M6 × 1.0	4.5 N·m (0.45 kgf·m, 3.3 lb·ft)
TCl unit bolt	M6 × 1.0	8 N·m (0.8 kgf·m, 5.9 lb·ft)
Stator coil assembly bolt	M5 × 0.8	3.4 N·m (0.34 kgf·m, 2.5 lb·ft)
Starter motor bolt	M8 × 1.25	18 N·m (1.8 kgf·m, 13 lb·ft)
Rectifier/regulator bolt	M6 × 1.0	7 N·m (0.7 kgf·m, 5.2 lb·ft)
Flywheel nut	M18 × 1.5	110 N·m (11 kgf·m, 81 lb·ft)
Governor arm bolt	M6 × 1.0	10 N·m (1.0 kgf·m, 7.4 lb·ft)
Throttle lever assembly bolt	M6 × 1.0	8 N·m (0.8 kgf·m, 5.9 lb·ft)
Accelerator lever nut (EH63K/ EH64A/EH64K/EH65A/EH65B)	M6 × 1.0	8 N·m (0.8 kgf·m, 5.9 lb·ft)
Free accelerator lever nut (EH72A/ EH72B/EH72K)	M6 × 1.0	7 N·m (0.7 kgf·m, 5.2 lb·ft)
Choke lever bolt (EH63K/EH64A/ EH64K/EH65A/EH65B)	M6 × 1.0	4.0 N·m (0.40 kgf·m, 3.0 lb·ft)
Spark plug	M14S × 1.25	13 N·m (1.3 kgf·m, 9.6 lb·ft)
Cylinder head cover bolt	M6 × 1.0	8 N·m (0.8 kgf·m, 5.9 lb·ft)
Cylinder head bolt	M10 × 1.25	1st: 25 N·m (2.5 kgf·m, 18 lb·ft) 2nd: 45 N·m (4.5 kgf·m, 33 lb·ft)
Rocker arm locknut	M6 × 0.75	8 N·m (0.8 kgf·m, 5.9 lb·ft)
Rocker arm pivot bolt	M6 × 0.75	18 N·m (1.8 kgf·m, 13 lb·ft)
Breather cover bolt	M6 × 1.0	3.9 N·m (0.39 kgf·m, 2.9 lb·ft)
Crankcase cover bolt	M8 × 1.25	25 N·m (2.5 kgf·m, 18 lb·ft)
Oil drain bolt	M14 × 1.5	21 N·m (2.1 kgf·m, 15 lb·ft)
Oil cooler bolt (EH72A/EH72B/ EH72K)	M6 × 1.0	8 N·m (0.8 kgf·m, 5.9 lb·ft)
Oil pump cover bolt	M6 × 1.0	8 N·m (0.8 kgf·m, 5.9 lb·ft)
Oil pressure switch	R1/8	8 N·m (0.8 kgf·m, 5.9 lb·ft)
Connecting rod cap bolt	M8 × 1.25	25 N·m (2.5 kgf·m, 18 lb·ft)
Fuel pump bolt	M6 × 1.0	5 N·m (0.5 kgf·m, 3.7 lb·ft)

TIGHTENING TORQUES

Item	Thread size	Tightening torque
Fuel pump bracket bolt	M6 × 1.0	8 N·m (0.8 kgf·m, 5.9 lb·ft)
Carburetor assembly bolt (EH63K/ EH64A/EH64K/EH65A/EH65B)	M8 × 1.25	18 N·m (1.8 kgf·m, 13 lb·ft)
Carburetor assembly nut (EH72A/ EH72B/EH72K)	M6 × 1.0	8 N·m (0.8 kgf·m, 5.9 lb·ft)
Throttle valve screw (EH63K/ EH64A/EH64K/EH65A/EH65B)	—	0.7 N·m (0.07 kgf·m, 0.52 lb·ft)
Throttle valve screw (EH72A/ EH72B/EH72K)	—	0.9 N·m (0.09 kgf·m, 0.66 lb·ft)
Choke valve screw (EH72A/ EH72B/EH72K)	—	0.9 N·m (0.09 kgf·m, 0.66 lb·ft)
Float chamber screw (EH72A/ EH72B/EH72K)	—	3.9 N·m (0.39 kgf·m, 2.9 lb·ft)
Carburetor drain screw (EH63K/ EH64A/EH64K/EH65A/EH65B)	—	2.0 N·m (0.20 kgf·m, 1.5 lb·ft)
Carburetor drain screw (EH72A/ EH72B/EH72K)	—	2.0 N·m (0.20 kgf·m, 1.5 lb·ft)

GENERAL TORQUE SPECIFICATIONS



















GENERAL TORQUE SPECIFICATIONS

This chart specifies torque for standard fasteners with standard I.S.O. pitch threads. Torque specifications for special components or assemblies are included in the applicable sections of this book. To avoid warpage, tighten multi fastener assemblies in a crisscross fashion, in progressive stages, until full torque is reached. Unless otherwise specifications call for clean, dry threads. Components should be at room temperature.

Thread size	Tightening torque		
	N·m	kgf·m	lb·ft
M4	2.0	0.20	1.5
M5	3.0	0.30	2.2
M6	7	0.7	5.2
M7	10	1.0	7.4
M8	15	1.5	11
M10	30	3.0	22
M12	60	6.0	44

LUBRICATION POINTS AND TYPE OF LUBRICANTS

LUBRICATION POINTS AND TYPE OF LUBRICANTS

Part name	Type of lubricant
Oil seal lip	
Governor fork oil seal lip	
Bearing	
Connecting rod big end	
Crank pin	
Crankshaft journal	
Connecting rod cap bolt	
Piston pin	
Piston	
Crankshaft gear teeth	
Valve stem	
Valve push rod end	
Camshaft lobe	
Camshaft gear teeth	
Camshaft journal	
Governor collar internal surface	
Governor fork meet surface	
Governor weight moving point	

WIRE ROUTING DIAGRAM

WIRE ROUTING DIAGRAM

FUEL PUMP AND FUEL HOSE (EH63K)

7
SPECIFICATIONS

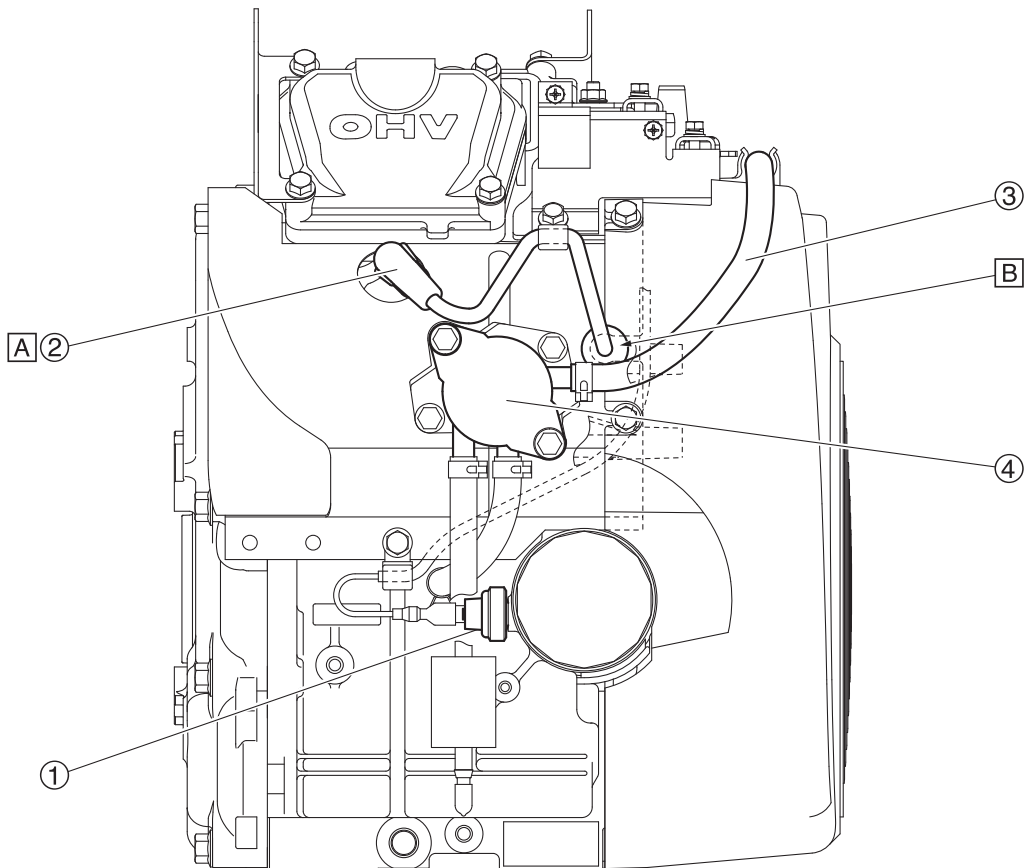

1. Oil pressure switch
2. Spark plug cap

3. Fuel hose
4. Fuel pump

- A. Point the spark plug cap in the direction shown in the illustration.
- B. Install the grommet all the way to the back of the fan case groove.

WIRE ROUTING DIAGRAM

FUEL PUMP AND FUEL HOSE (EH64A)

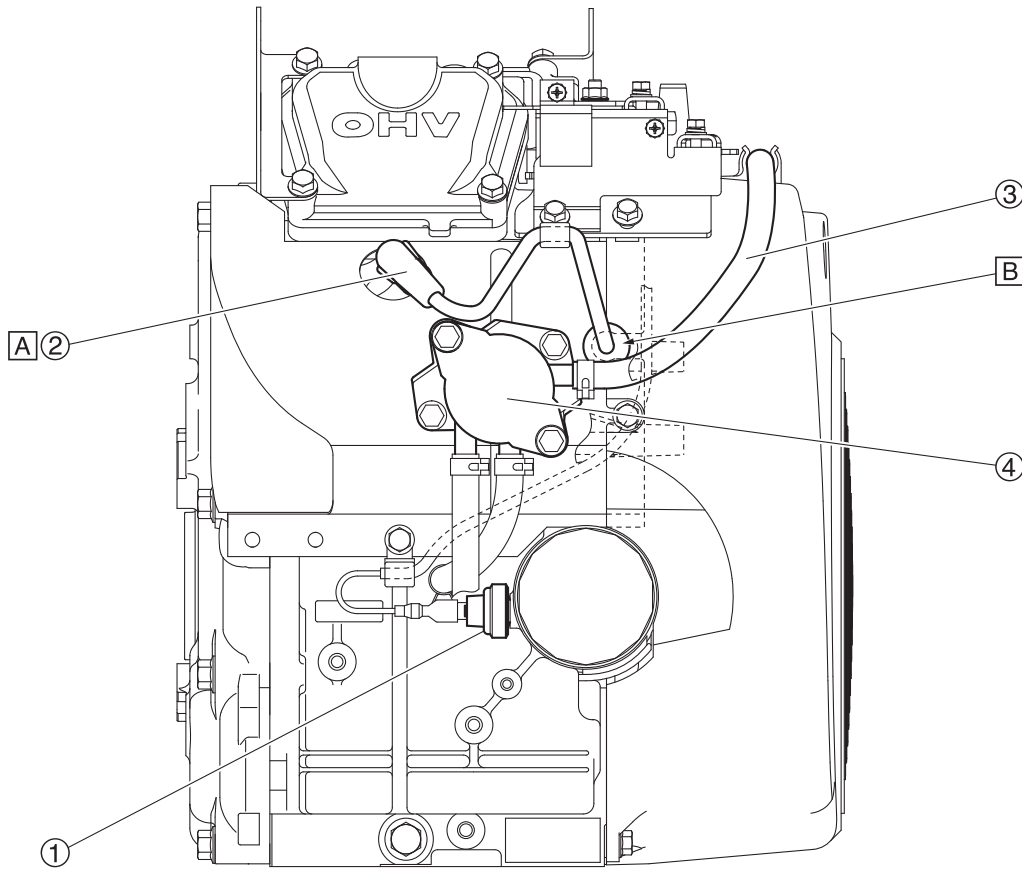

- 1. Oil pressure switch
- 2. Spark plug cap

- 3. Fuel hose
- 4. Fuel pump

- A. Point the spark plug cap in the direction shown in the illustration.
- B. Install the grommet all the way to the back of the fan case groove.

WIRE ROUTING DIAGRAM

FUEL PUMP AND FUEL HOSE (EH64K, EXCEPT FOR KOR)

7
SPECIFICATIONS

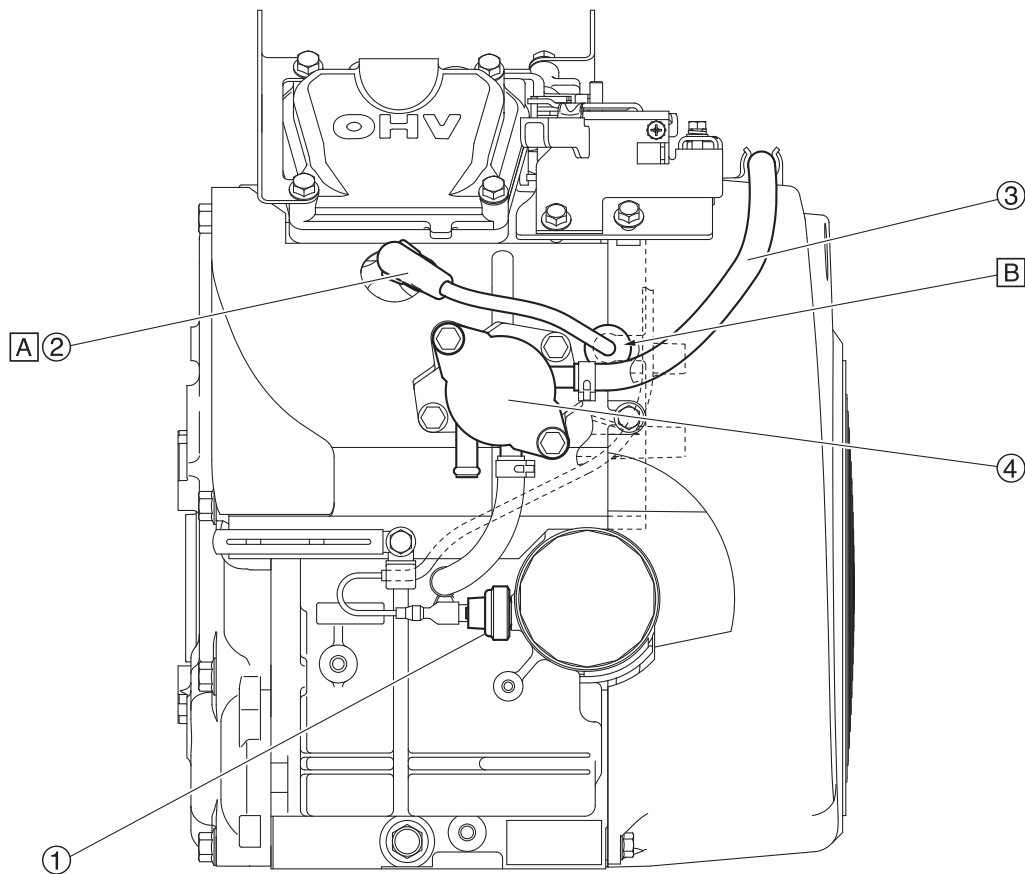

- 1. Oil pressure switch
- 2. Spark plug cap

- 3. Fuel hose
- 4. Fuel pump

- A. Point the spark plug cap in the direction shown in the illustration.
- B. Install the grommet all the way to the back of the fan case groove.

WIRE ROUTING DIAGRAM

FUEL PUMP AND FUEL HOSE (EH64K, FOR KOR)

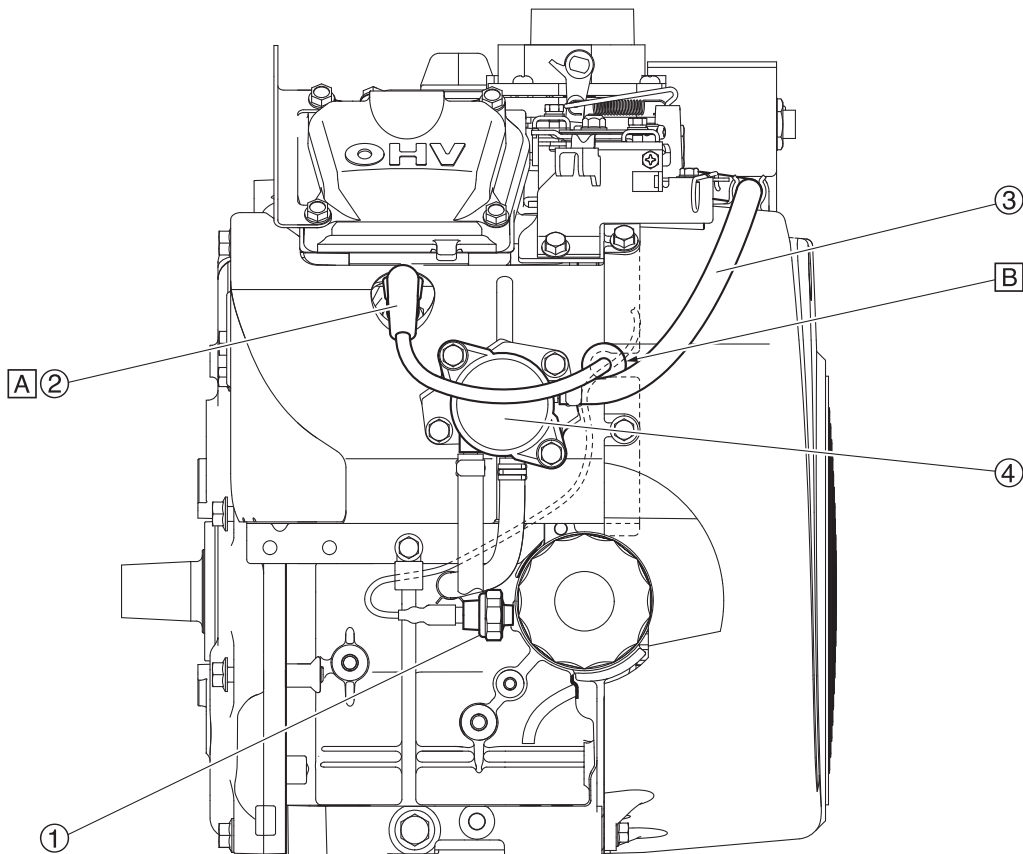

- 1. Oil pressure switch
- 2. Spark plug cap

- 3. Fuel hose
- 4. Fuel pump

- A. Point the spark plug cap in the direction shown in the illustration.
- B. Install the grommet all the way to the back of the fan case groove.

WIRE ROUTING DIAGRAM

FUEL PUMP AND FUEL HOSE (EH65A)

7
SPECIFICATIONS

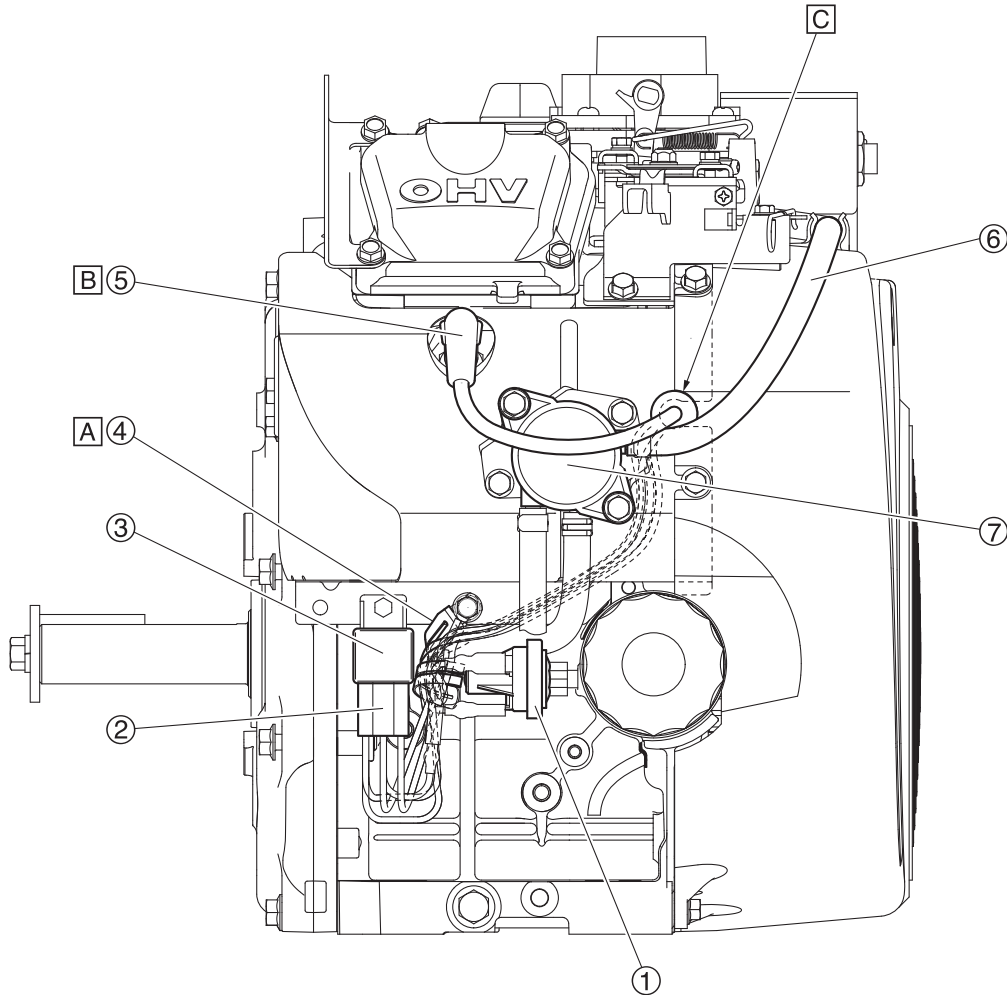

1. Oil pressure switch
2. Wire harness assembly
3. Relay
4. Clamp
5. Spark plug cap
6. Fuel hose
7. Fuel pump

- A. Clamp all wire leads after winding 1.5 or more turns.
- B. Point the spark plug cap in the direction shown in the illustration.
- C. Install the grommet all the way to the back of the fan case groove.

WIRE ROUTING DIAGRAM

FUEL PUMP AND FUEL HOSE (EH65B)

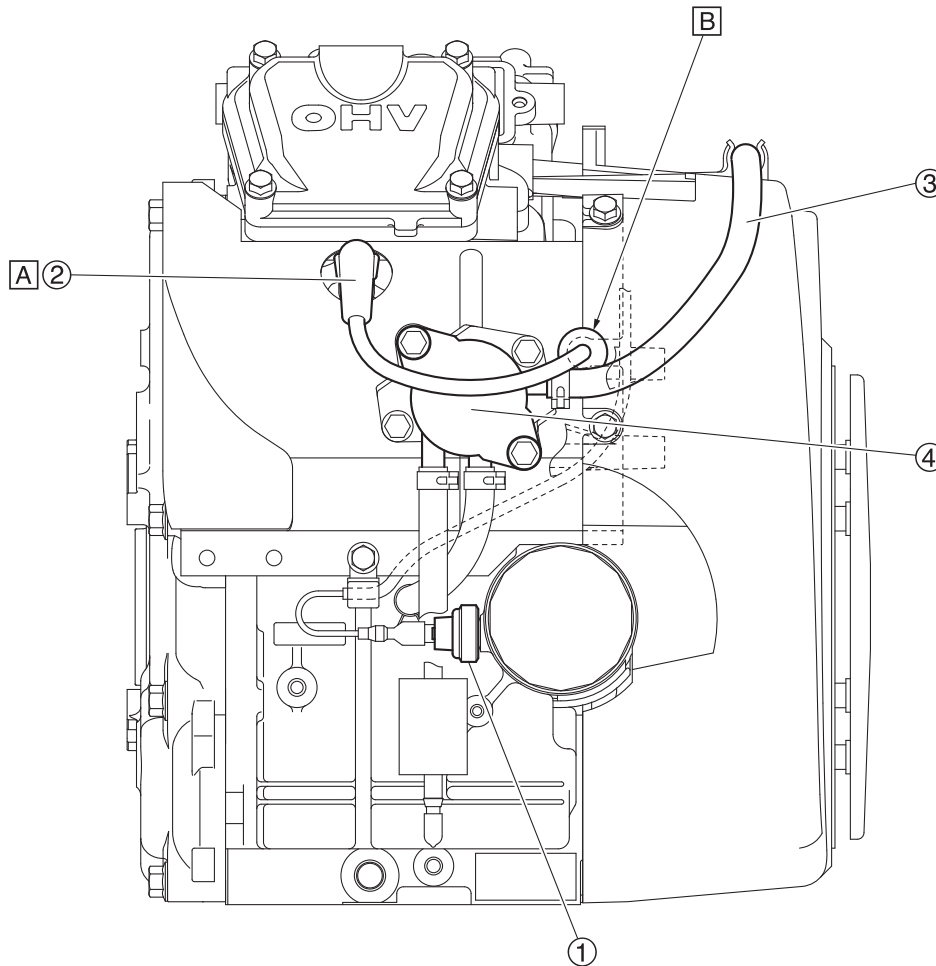

- 1. Oil pressure switch
- 2. Spark plug cap

- 3. Fuel hose
- 4. Fuel pump

- A. Point the spark plug cap in the direction shown in the illustration.
- B. Install the grommet all the way to the back of the fan case groove.

WIRE ROUTING DIAGRAM

FUEL PUMP AND FUEL HOSE (EH72A)

7
SPECIFICATIONS

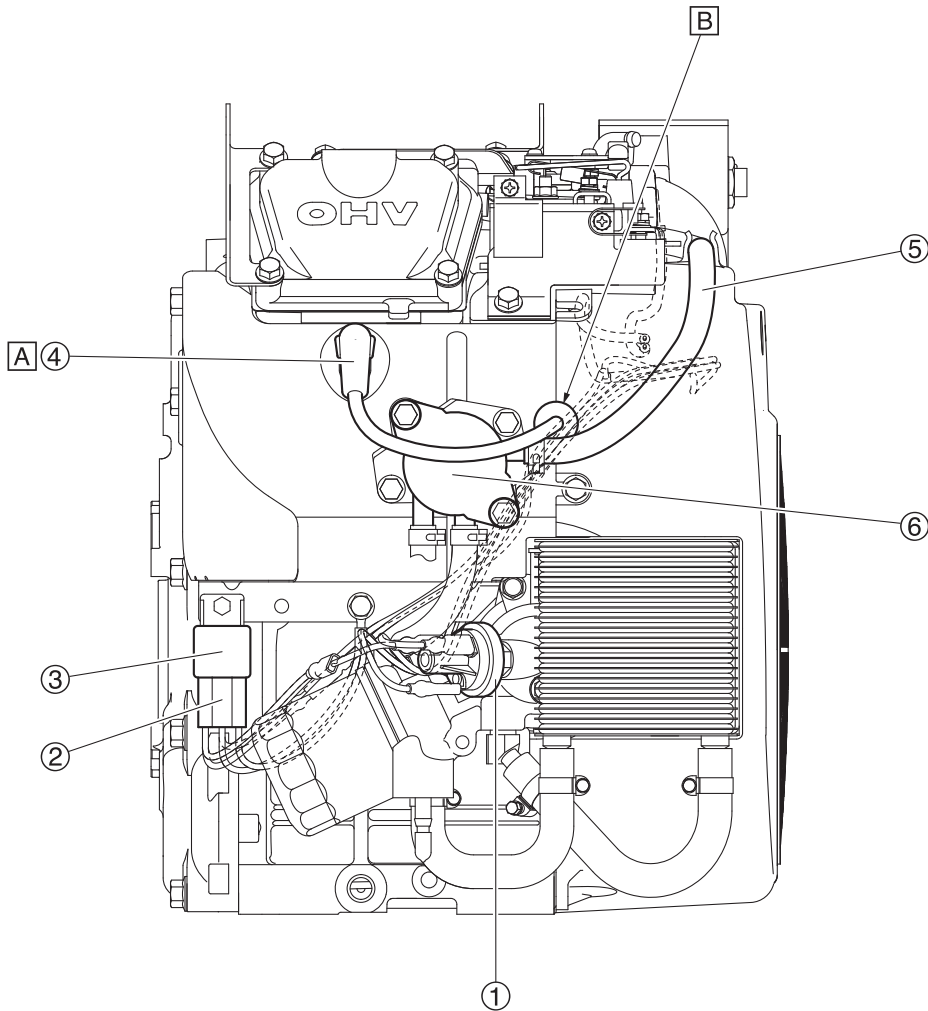

1. Oil pressure switch
 2. Wire harness assembly
 3. Relay
 4. Spark plug cap
 5. Fuel hose
 6. Fuel pump
- A. Point the spark plug cap in the direction shown in the illustration.
B. Install the grommet all the way to the back of the fan case groove.

WIRE ROUTING DIAGRAM

FUEL PUMP AND FUEL HOSE (EH72B, FOR SEA/EH72K, FOR CHN)

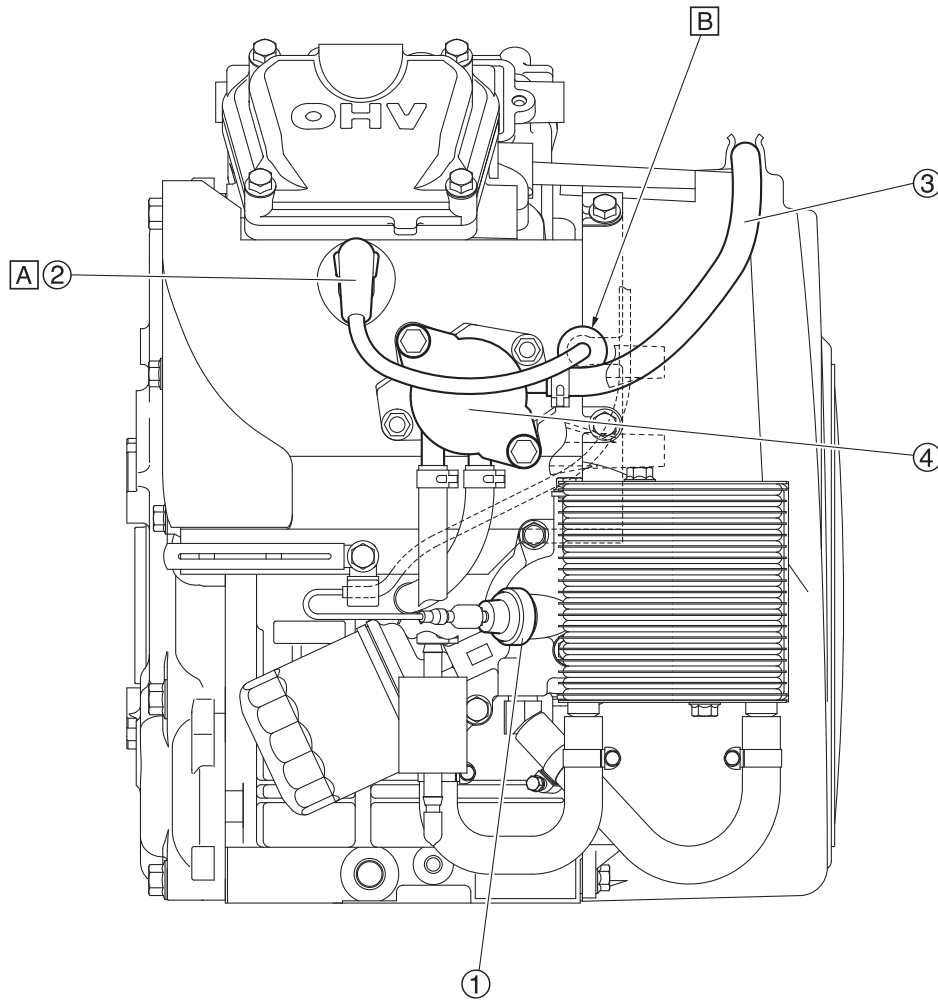

- 1. Oil pressure switch
 - 2. Spark plug cap
 - 3. Fuel hose
 - 4. Fuel pump
- A. Point the spark plug cap in the direction shown in the illustration.
B. Install the grommet all the way to the back of the fan case groove.

WIRE ROUTING DIAGRAM

FUEL PUMP AND FUEL HOSE (EH72K, EXCEPT FOR CHN)

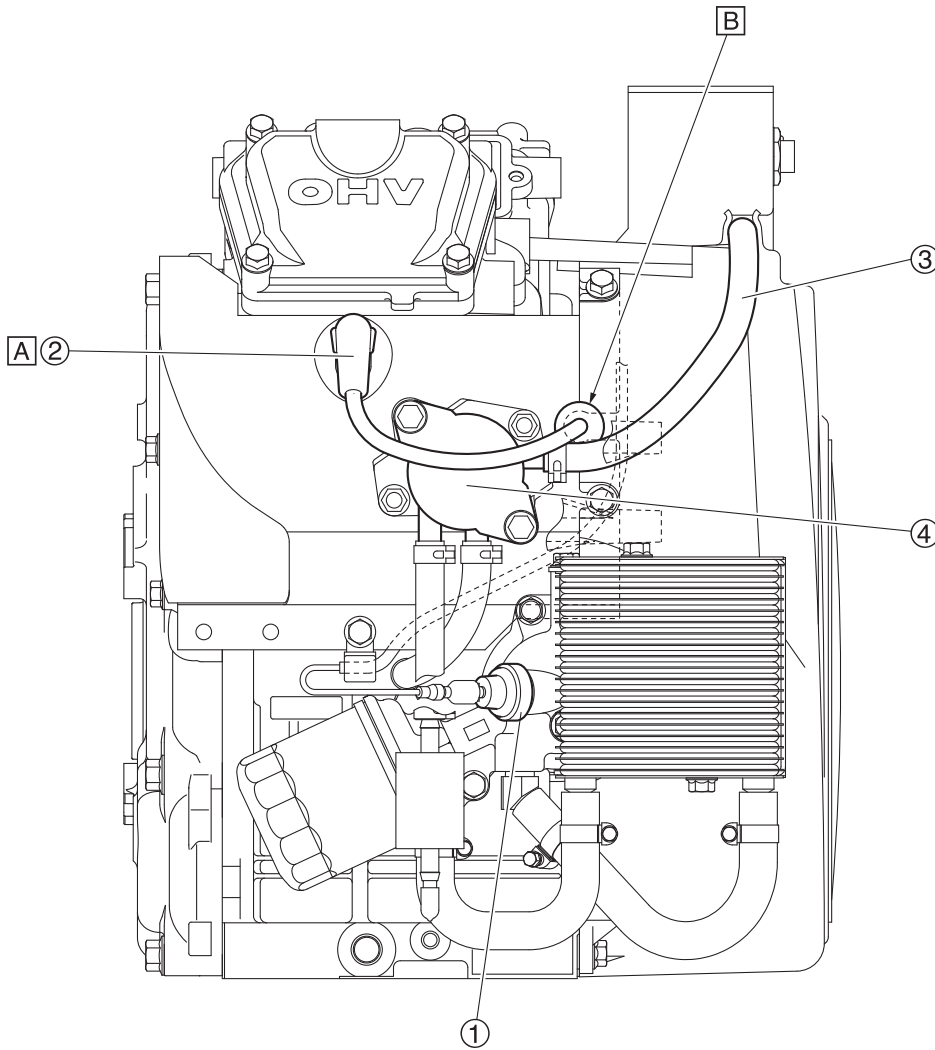

- 1. Oil pressure switch
 - 2. Spark plug cap
 - 3. Fuel hose
 - 4. Fuel pump
- A. Point the spark plug cap in the direction shown in the illustration.
B. Install the grommet all the way to the back of the fan case groove.

WIRE ROUTING DIAGRAM

AIR FILTER, CARBURETOR AND FUEL HOSE (EH63K/EH64A/EH64K, EXCEPT FOR KOR)

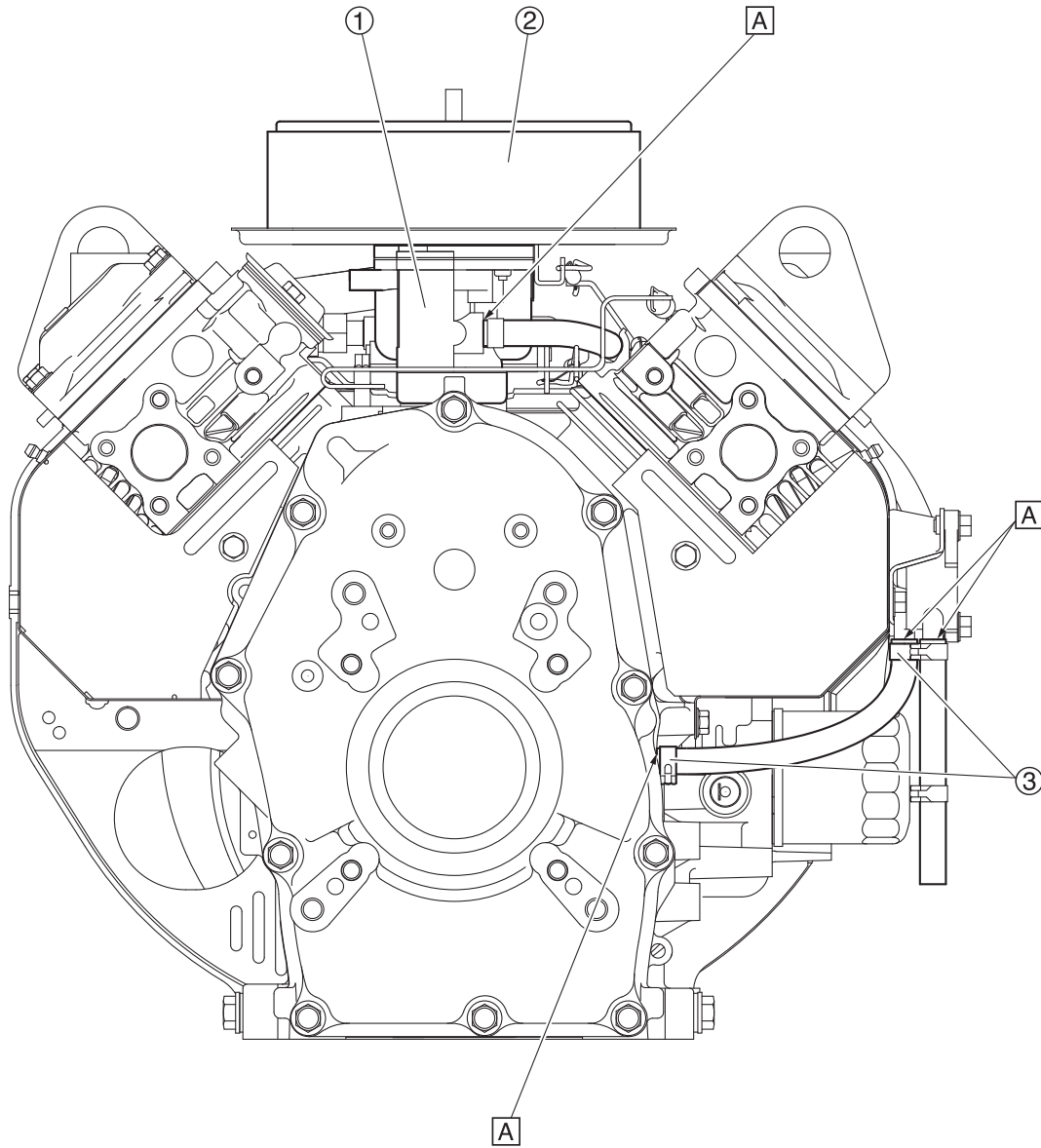

- 1. Carburetor
- 2. Air filter element

- 3. Clamp

A. Insert the hose until it hits.

WIRE ROUTING DIAGRAM

AIR FILTER, CARBURETOR AND FUEL HOSE (EH64K, FOR KOR/EH65A/EH65B)

7
SPECIFICATIONS

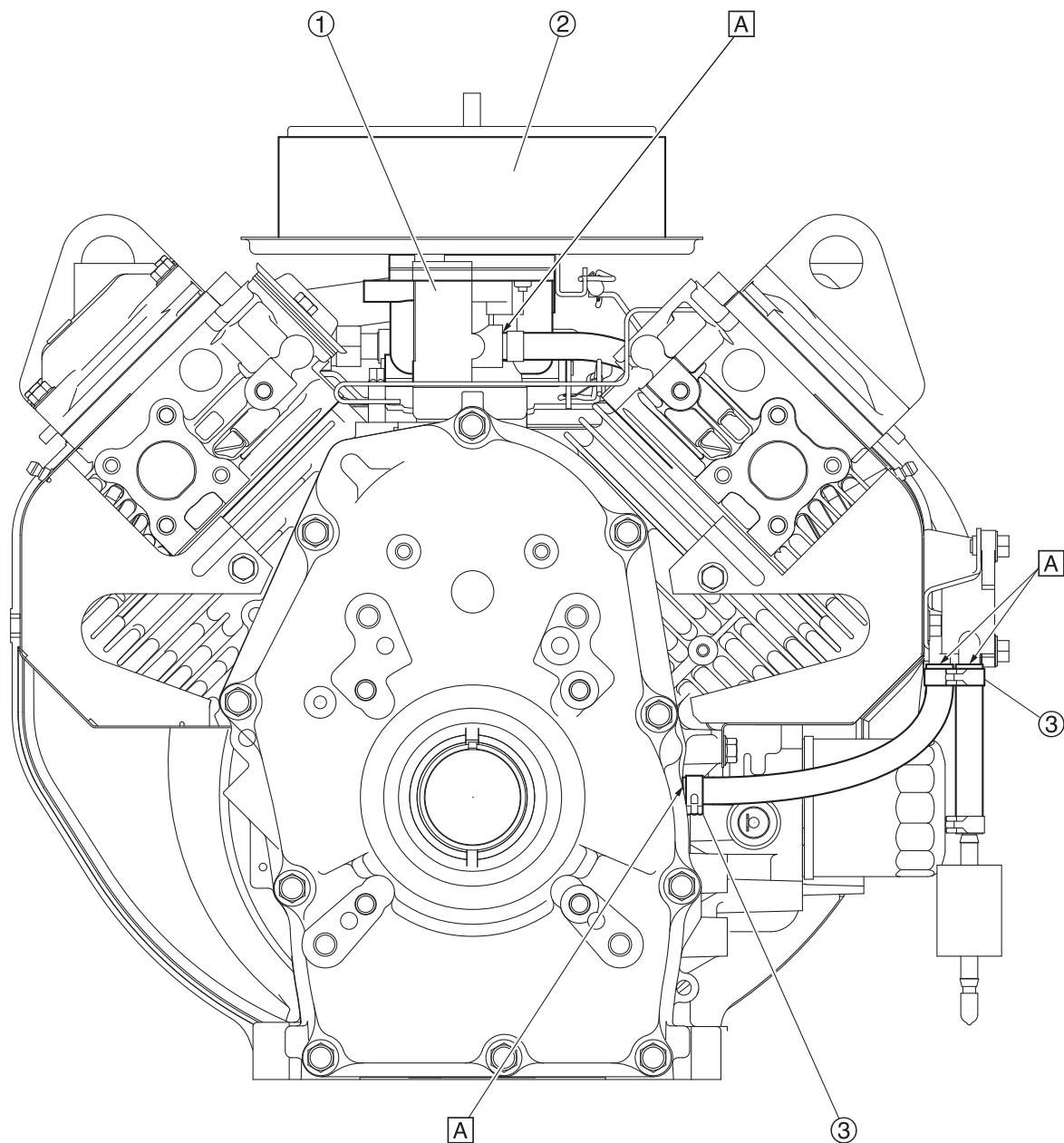

- 1. Carburetor
- 2. Air filter element

- 3. Clamp

A. Insert the hose until it hits.

WIRE ROUTING DIAGRAM

AIR FILTER, CARBURETOR AND FUEL HOSE (EH72A/EH72B/EH72K)

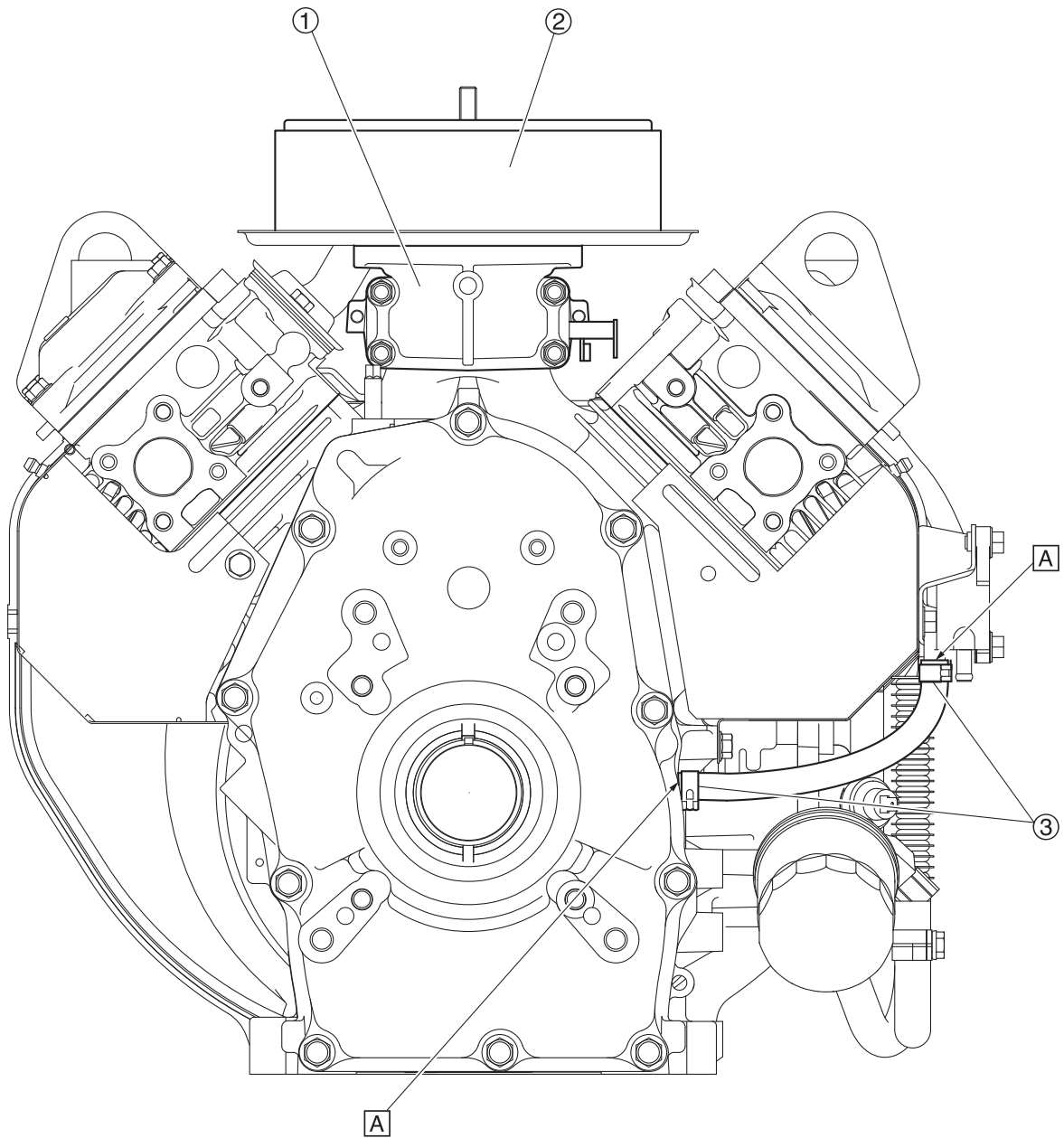

- 1. Carburetor
- 2. Air filter element

- 3. Clamp

- A. Insert the hose until it hits.

WIRE ROUTING DIAGRAM

CARBURETOR AND INTAKE MANIFOLD (EH64A/EH64K, EXCEPT FOR KOR)

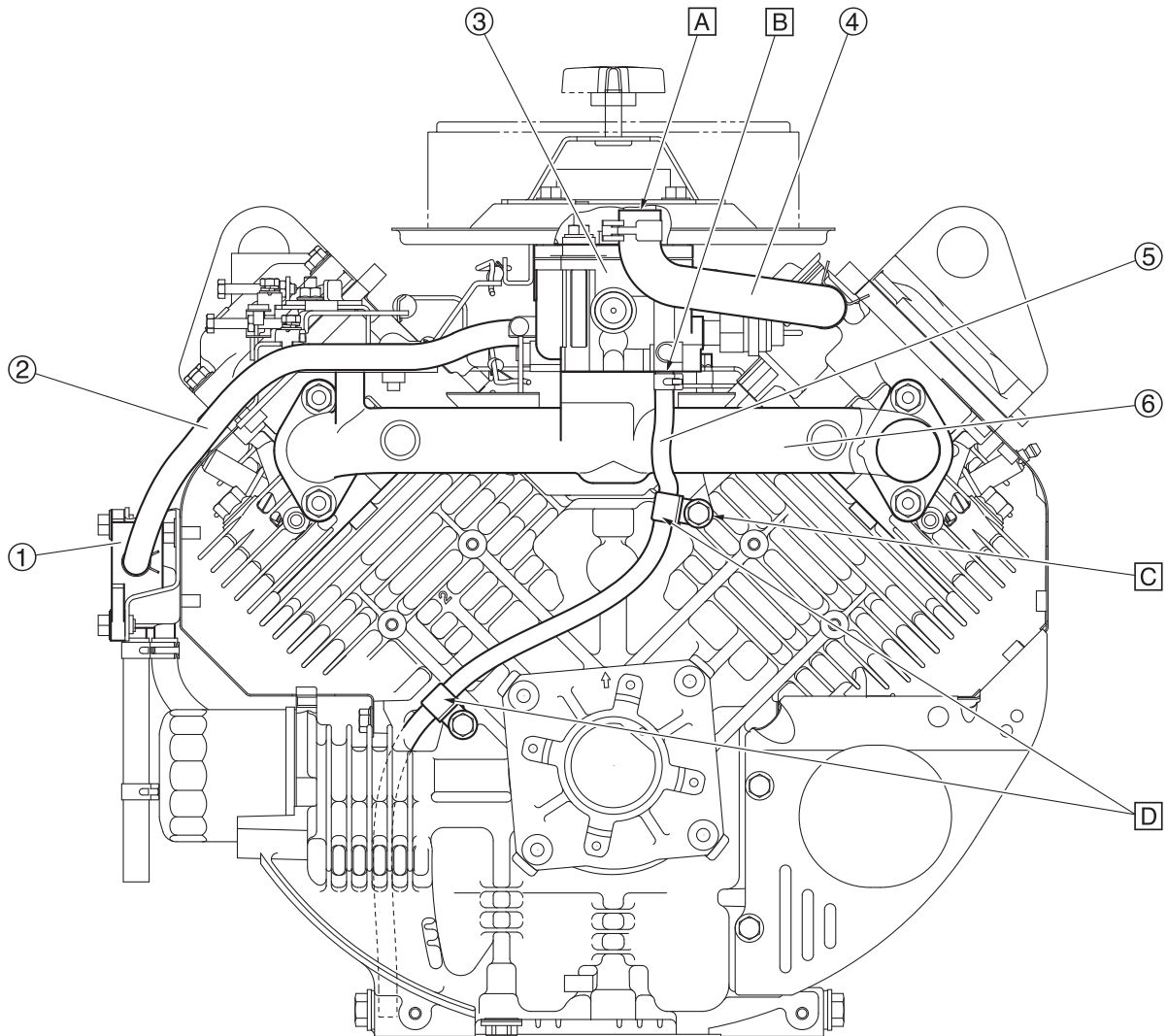

- 1. Fuel pump
- 2. Fuel hose
- 3. Carburetor

- 4. Breather hose
- 5. Carburetor breather hose
- 6. Intake manifold

- A. Insert the breather hose to the base.
- B. Insert the carburetor breather hose to the base of the carburetor pipe.
- C. Tighten together with the bracket.
- D. Install the clamp at the position shown in the illustration.

WIRE ROUTING DIAGRAM

CARBURETOR AND INTAKE MANIFOLD (EH64K, FOR KOR/EH65A/EH65B)

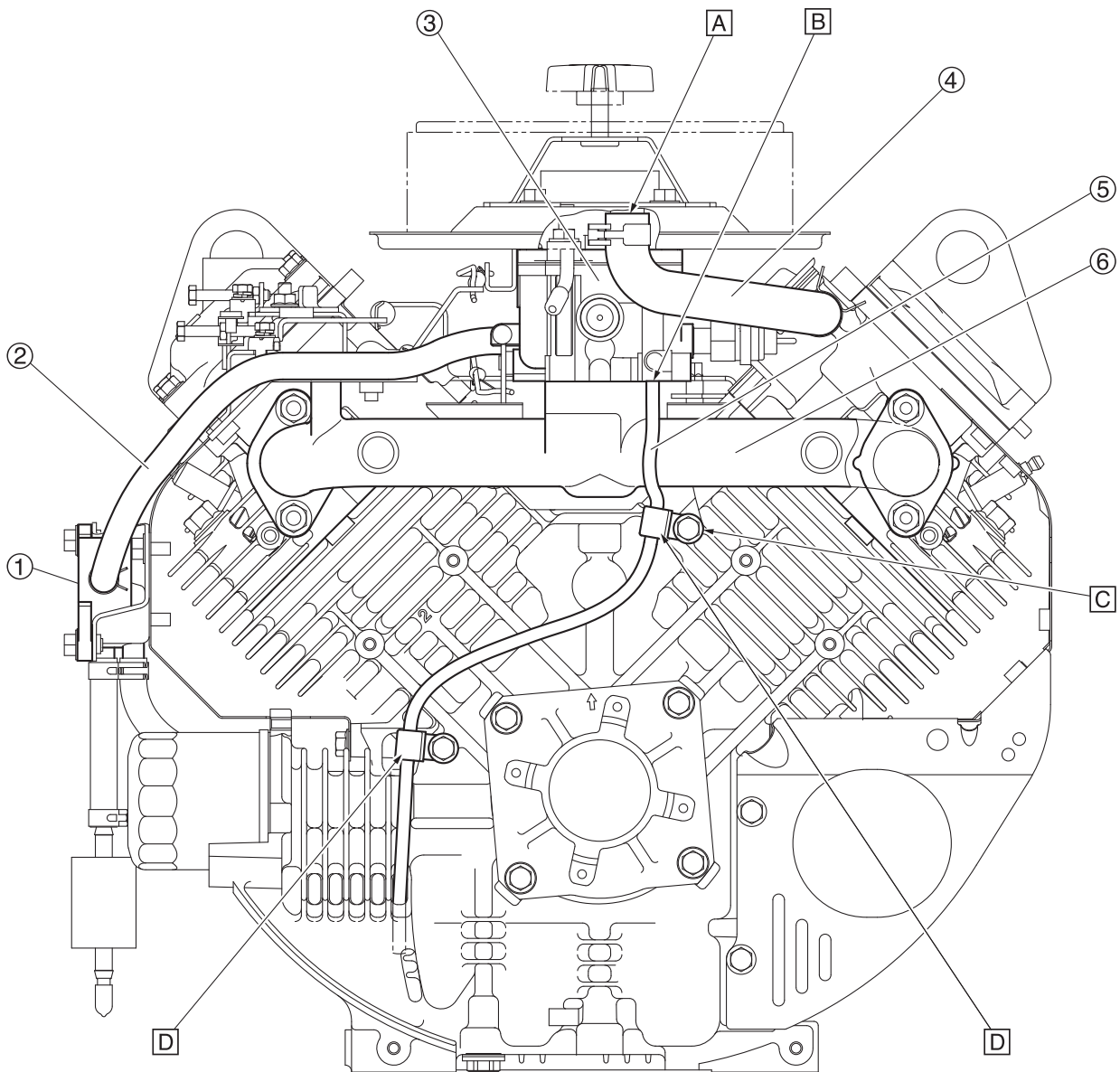

1. Fuel pump
2. Fuel hose
3. Carburetor

4. Breather hose
5. Carburetor breather hose
6. Intake manifold

- A. Insert the breather hose to the base.
- B. Insert the carburetor breather hose to the base of the carburetor pipe.
- C. Tighten together with the bracket.
- D. Install the clamp at the position shown in the illustration.

WIRE ROUTING DIAGRAM

CARBURETOR AND INTAKE MANIFOLD (EH72A/EH72B/EH72K)

7
SPECIFICATIONS

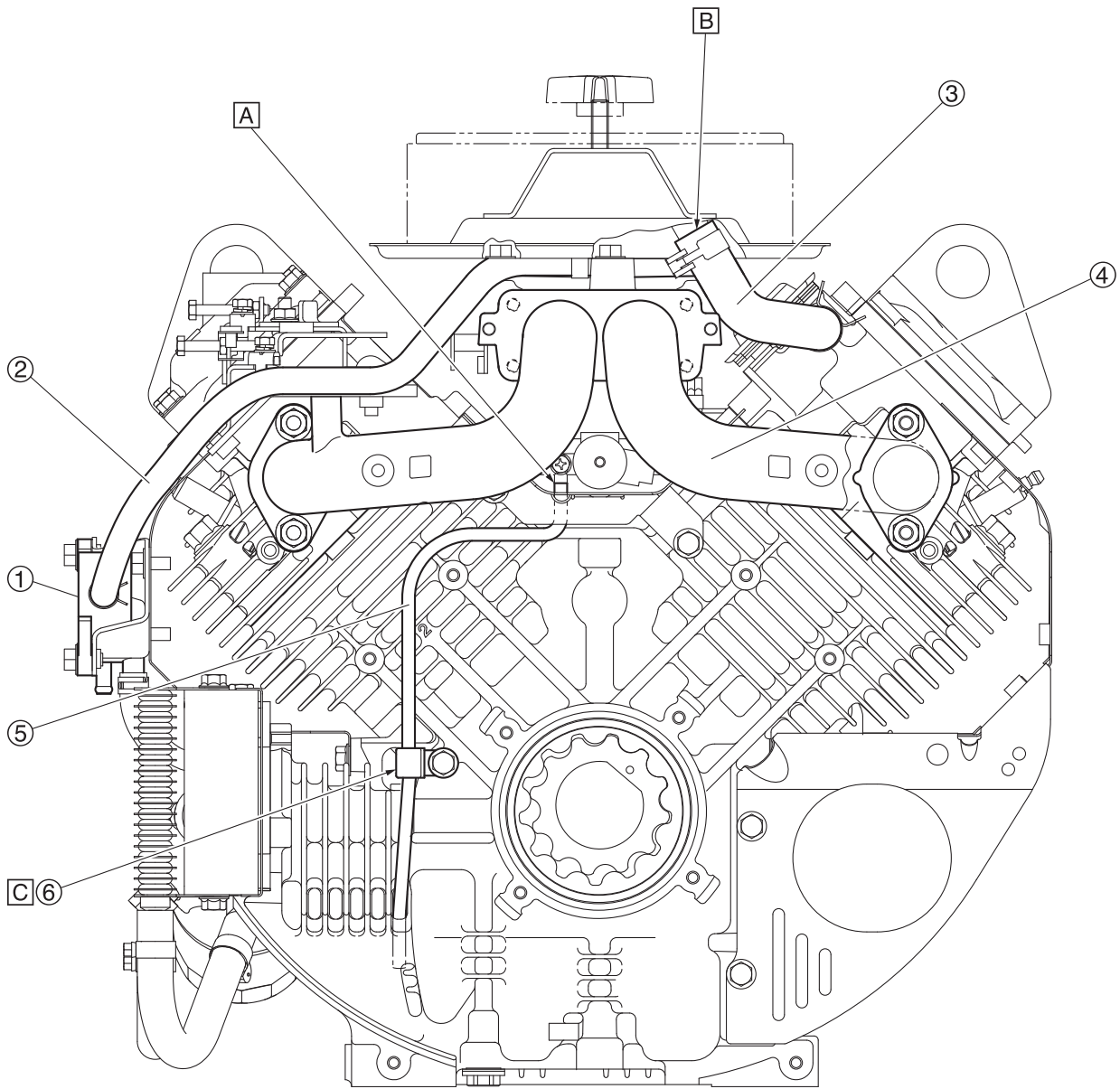

- | | |
|------------------|-----------------------------|
| 1. Fuel pump | 4. Intake manifold |
| 2. Fuel hose | 5. Carburetor breather hose |
| 3. Breather hose | 6. Clamp |

- A. Insert the carburetor breather hose to the base of the carburetor pipe.
- B. Insert the breather hose to the base.
- C. Install the clamp at the position shown in the illustration.

WIRE ROUTING DIAGRAM

TCI UNIT (EH63K)

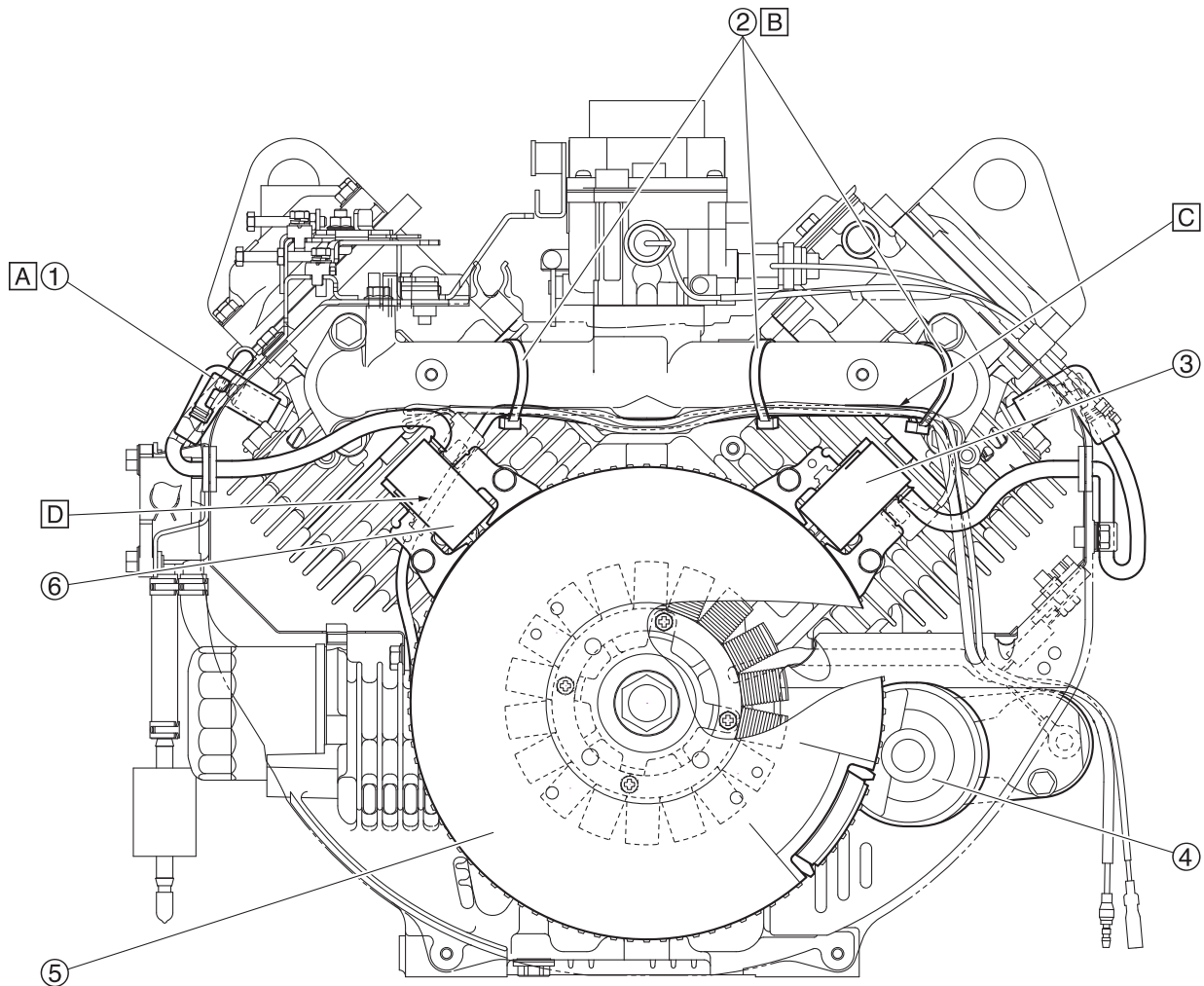

- 1. Terminal
- 2. Plastic locking tie
- 3. TCI unit #1
- 4. Starter motor
- 5. Flywheel
- 6. TCI unit #2

- A. For the terminal, install the spark plug cap after caulking to the high tension cord.
- B. Position the lock portion on the lower side of the intake manifold. Cut the extra portion plastic locking tie so that projection is 0 mm (0 in).
- C. There should be no looseness or tightness of the lead. Adjustment before and after the plastic locking tie.
- D. Route over the TCI unit mount.

WIRE ROUTING DIAGRAM

TCI UNIT (EH64A)

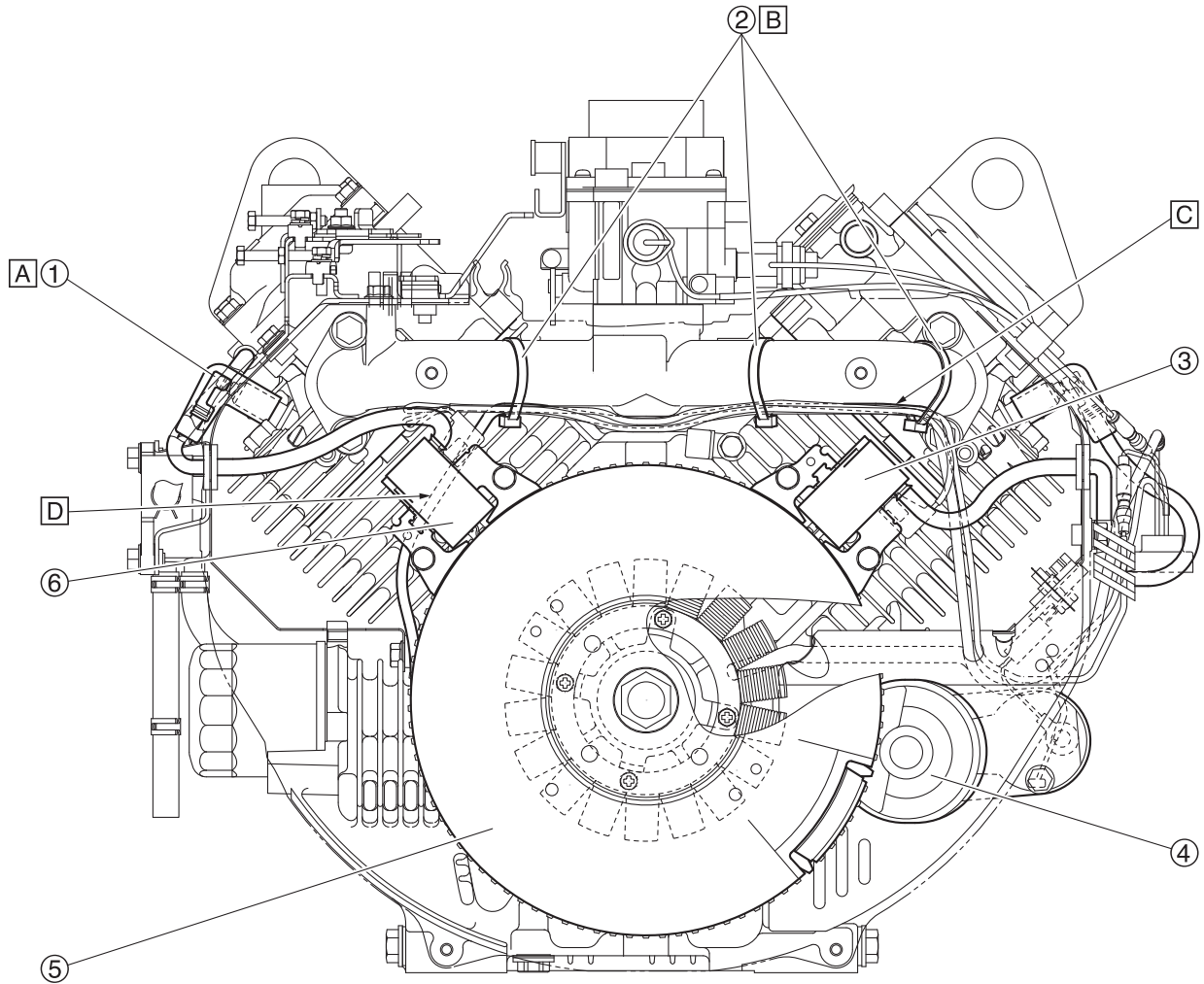

- 1. Terminal
- 2. Plastic locking tie
- 3. TCI unit #1

- 4. Starter motor
- 5. Flywheel
- 6. TCI unit #2

- A. For the terminal, install the spark plug cap after caulking to the high tension cord.
- B. Position the lock portion on the lower side of the intake manifold. Cut the extra portion plastic locking tie so that projection is 0 mm (0 in).
- C. There should be no looseness or tightness of the lead. Adjustment before and after the plastic locking tie.
- D. Route over the TCI unit mount.

WIRE ROUTING DIAGRAM

TCI UNIT (EH64K, EXCEPT FOR KOR)

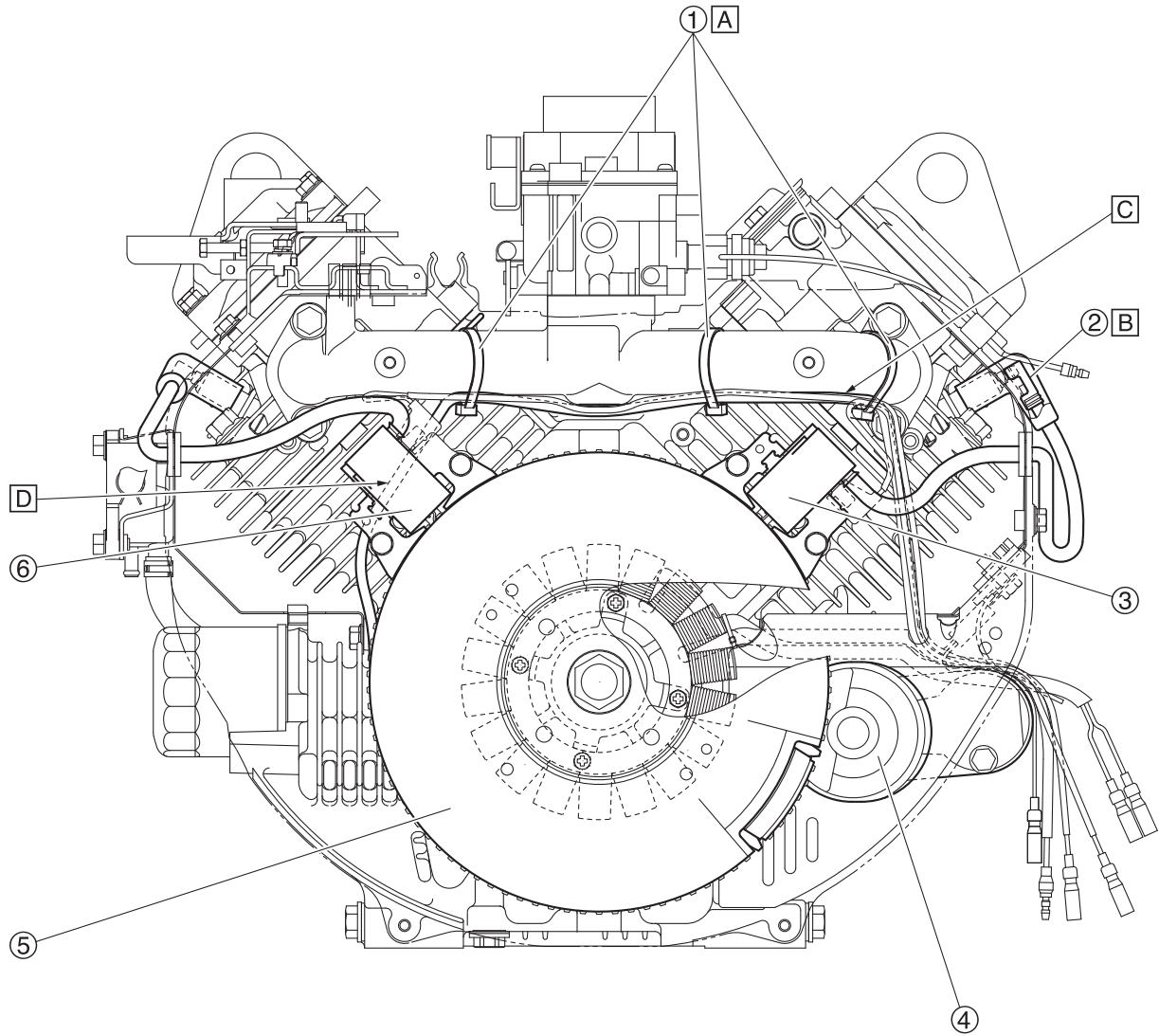

- 1. Plastic locking tie
- 2. Terminal
- 3. TCI unit #1
- 4. Starter motor
- 5. Flywheel
- 6. TCI unit #2

- A. Position the lock portion on the lower side of the intake manifold. Cut the extra portion plastic locking tie so that projection is 0 mm (0 in).
- B. For the terminal, install the spark plug cap after caulking to the high tension cord.
- C. There should be no looseness or tightness of the lead. Adjustment before and after the plastic locking tie.
- D. Route over the TCI unit mount.

WIRE ROUTING DIAGRAM

TCI UNIT (EH64K, FOR KOR)

7
SPECIFICATIONS

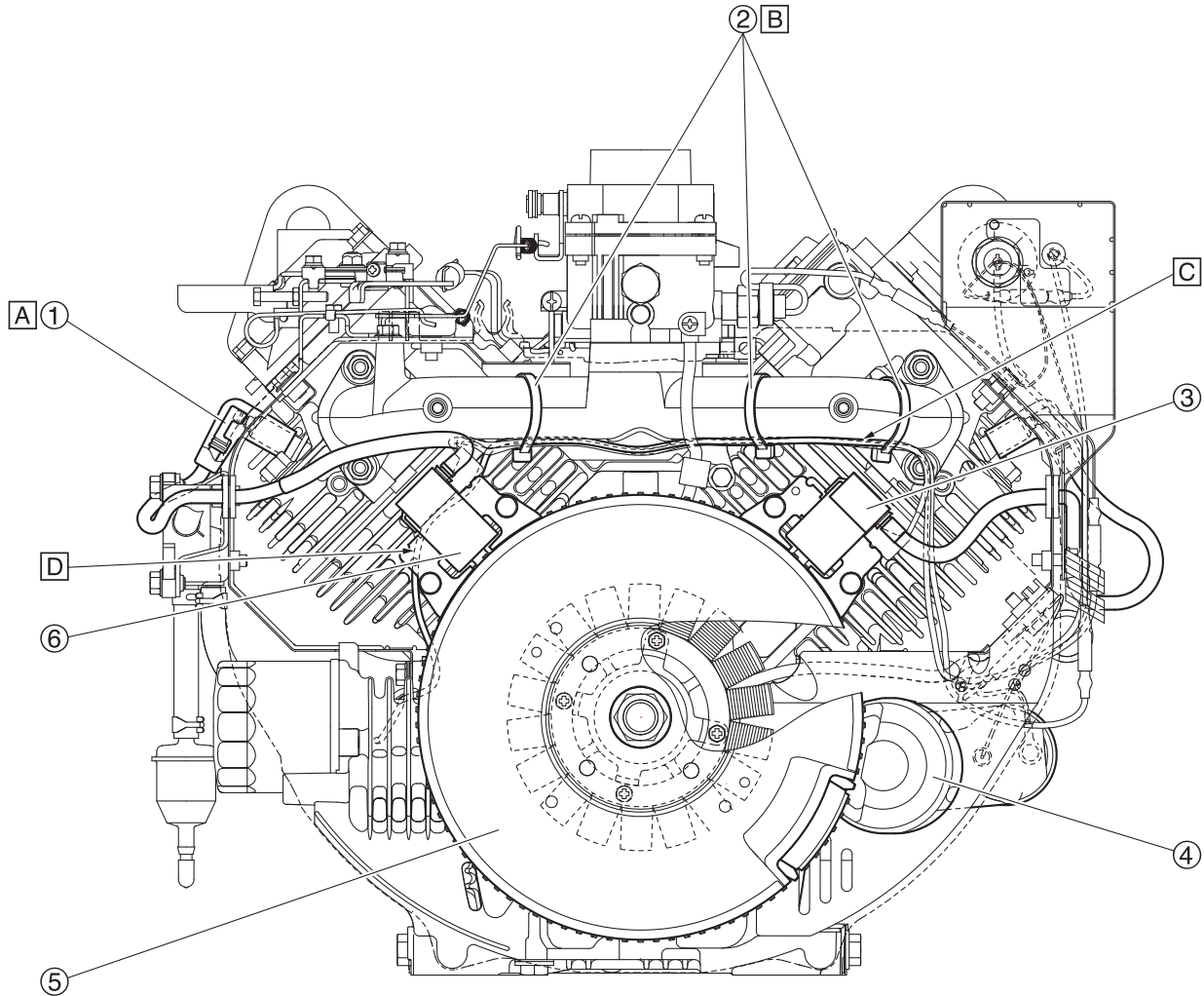

- 1. Terminal
- 2. Plastic locking tie
- 3. TCI unit #1
- 4. Starter motor
- 5. Flywheel
- 6. TCI unit #2

- A. For the terminal, install the spark plug cap after caulking to the high tension cord.
- B. Position the lock portion on the lower side of the intake manifold. Cut the extra portion plastic locking tie so that projection is 0 mm (0 in).
- C. There should be no looseness or tightness of the lead. Adjustment before and after the plastic locking tie.
- D. Route over the TCI unit mount.

WIRE ROUTING DIAGRAM

TCI UNIT (EH65A)

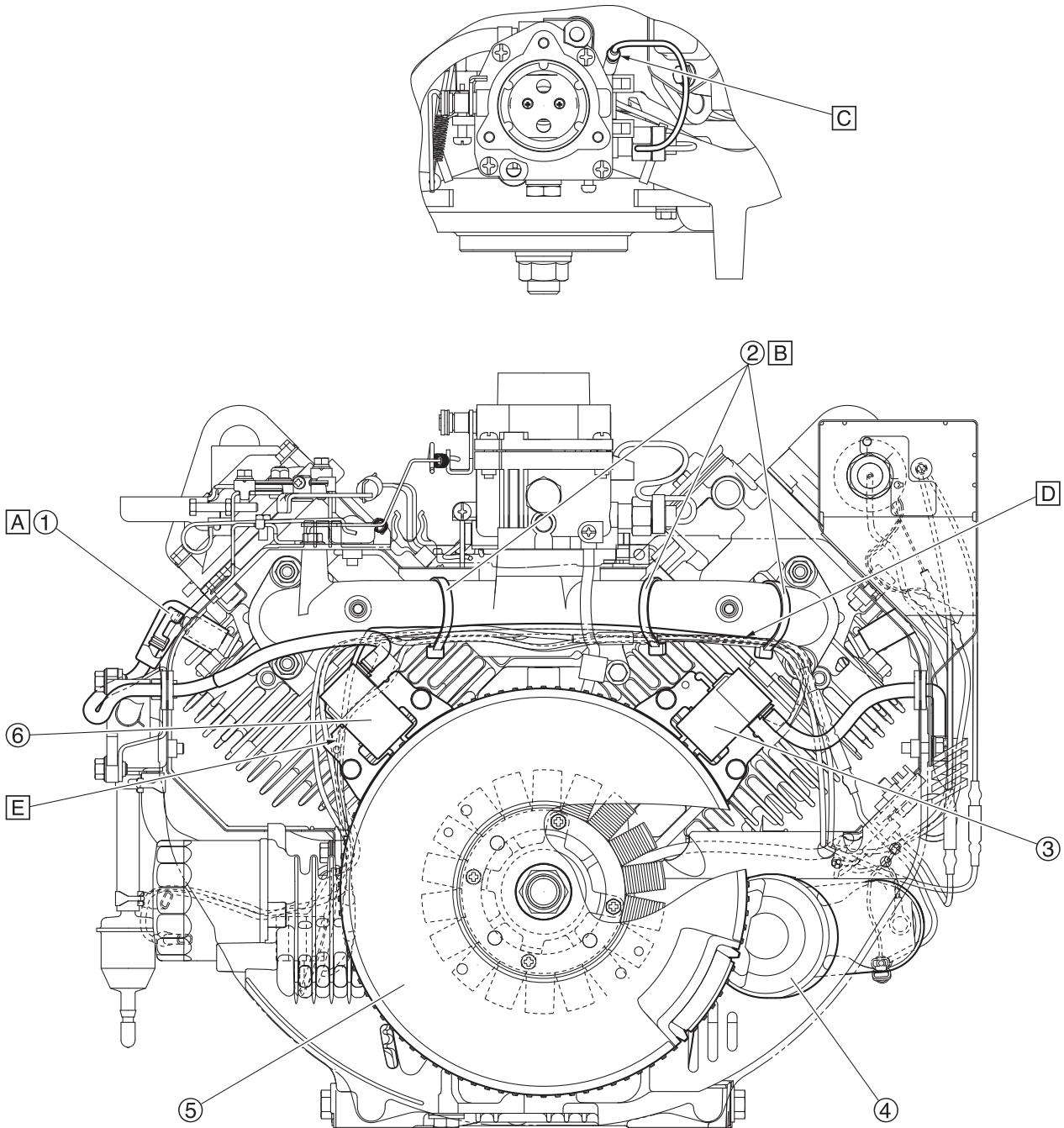

- 1. Terminal
- 2. Plastic locking tie
- 3. TCI unit #1
- 4. Starter motor
- 5. Flywheel
- 6. TCI unit #2

- A. For the terminal, install the spark plug cap after caulking to the high tension cord.
- B. Position the lock portion on the lower side of the intake manifold. Cut the extra portion plastic locking tie so that projection is 0 mm (0 in).
- C. Connect the carburetor terminal to red lead.
- D. There should be no looseness or tightness of the lead. Adjustment before and after the plastic locking tie.
- E. Route over the TCI unit mount.

WIRE ROUTING DIAGRAM

TCI UNIT (EH65B)

7
SPECIFICATIONS

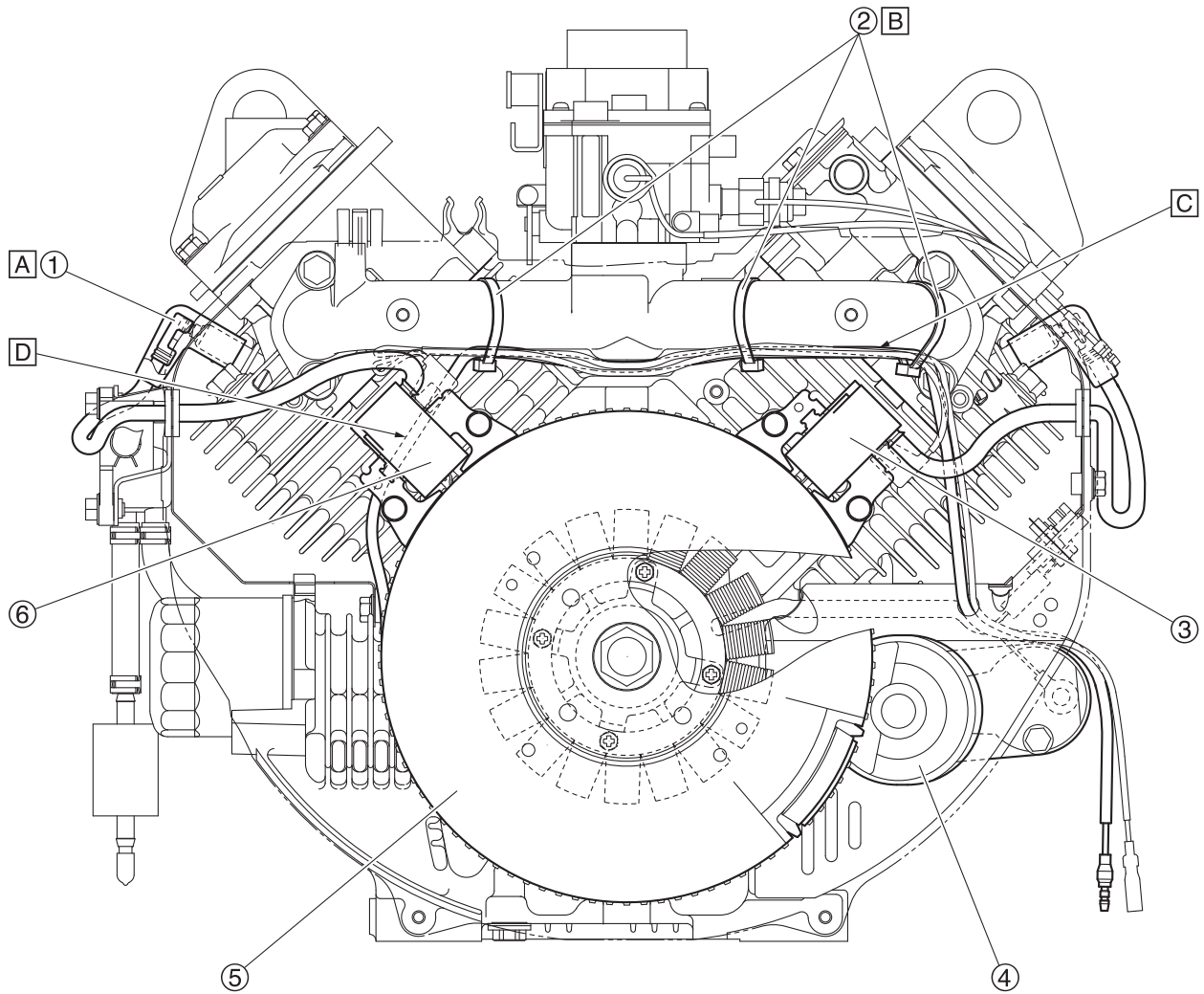

- 1. Terminal
- 2. Plastic locking tie
- 3. TCI unit #1

- 4. Starter motor
- 5. Flywheel
- 6. TCI unit #2

- A. For the terminal, install the spark plug cap after caulking to the high tension cord.
- B. Position the lock portion on the lower side of the intake manifold. Cut the extra portion plastic locking tie so that projection is 0 mm (0 in).
- C. There should be no looseness or tightness of the lead. Adjustment before and after the plastic locking tie.
- D. Route over the TCI unit mount.

WIRE ROUTING DIAGRAM

TCI UNIT (EH72A)

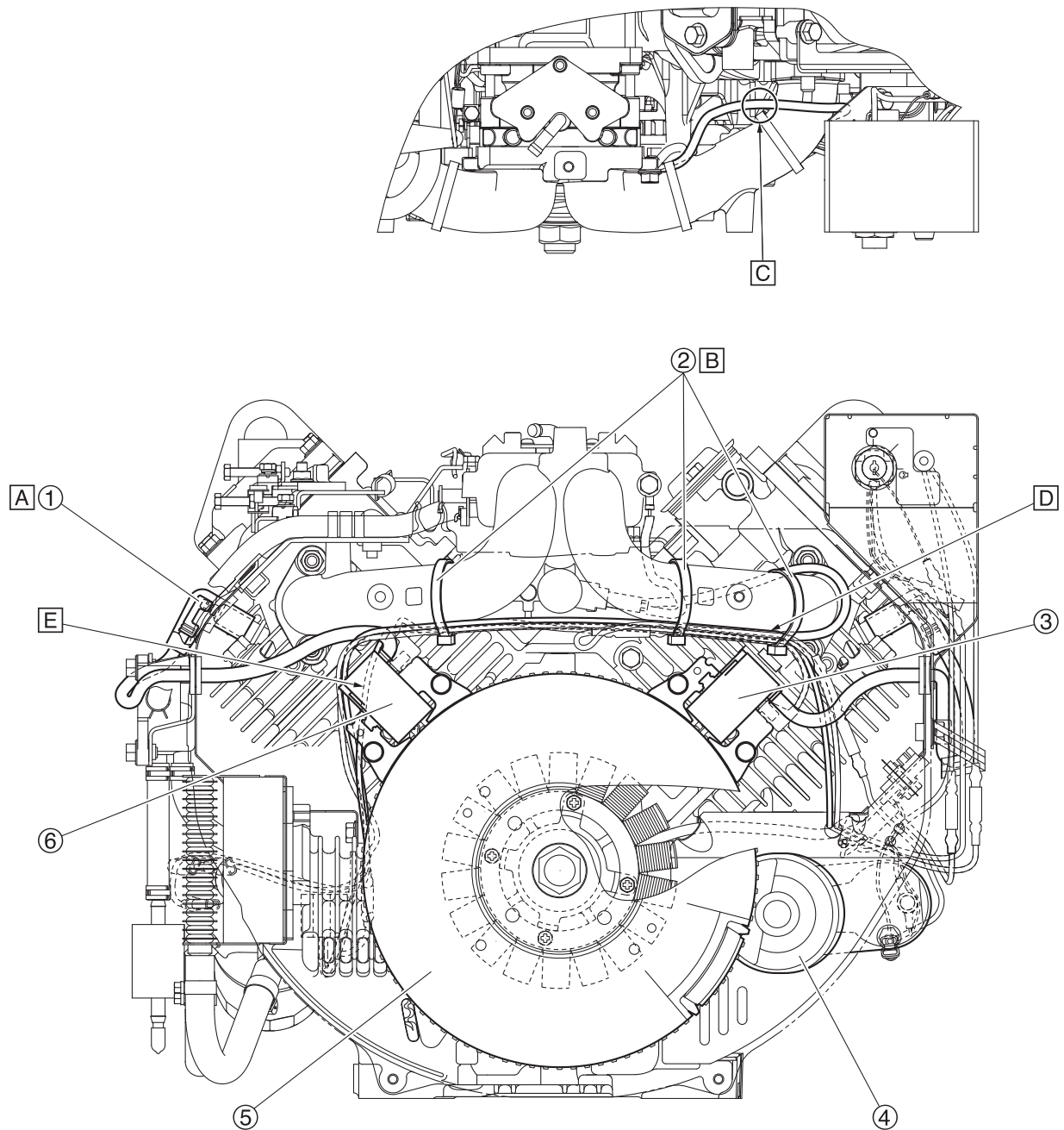

- 1. Terminal
- 2. Plastic locking tie
- 3. TCI unit #1
- 4. Starter motor
- 5. Flywheel
- 6. TCI unit #2

- A. For the terminal, install the spark plug cap after caulking to the high tension cord.
- B. Position the lock portion on the lower side of the intake manifold. Cut the extra portion plastic locking tie so that projection is 0 mm (0 in).
- C. Red wire connection of wire lead 1 terminal does not bind only in this place.
- D. There should be no looseness or tightness of the lead. Adjustment before and after the plastic locking tie.
- E. Route over the TCI unit mount.

WIRE ROUTING DIAGRAM

TCI UNIT (EH72B, FOR SEA/EH72K, FOR CHN)

7
SPECIFICATIONS

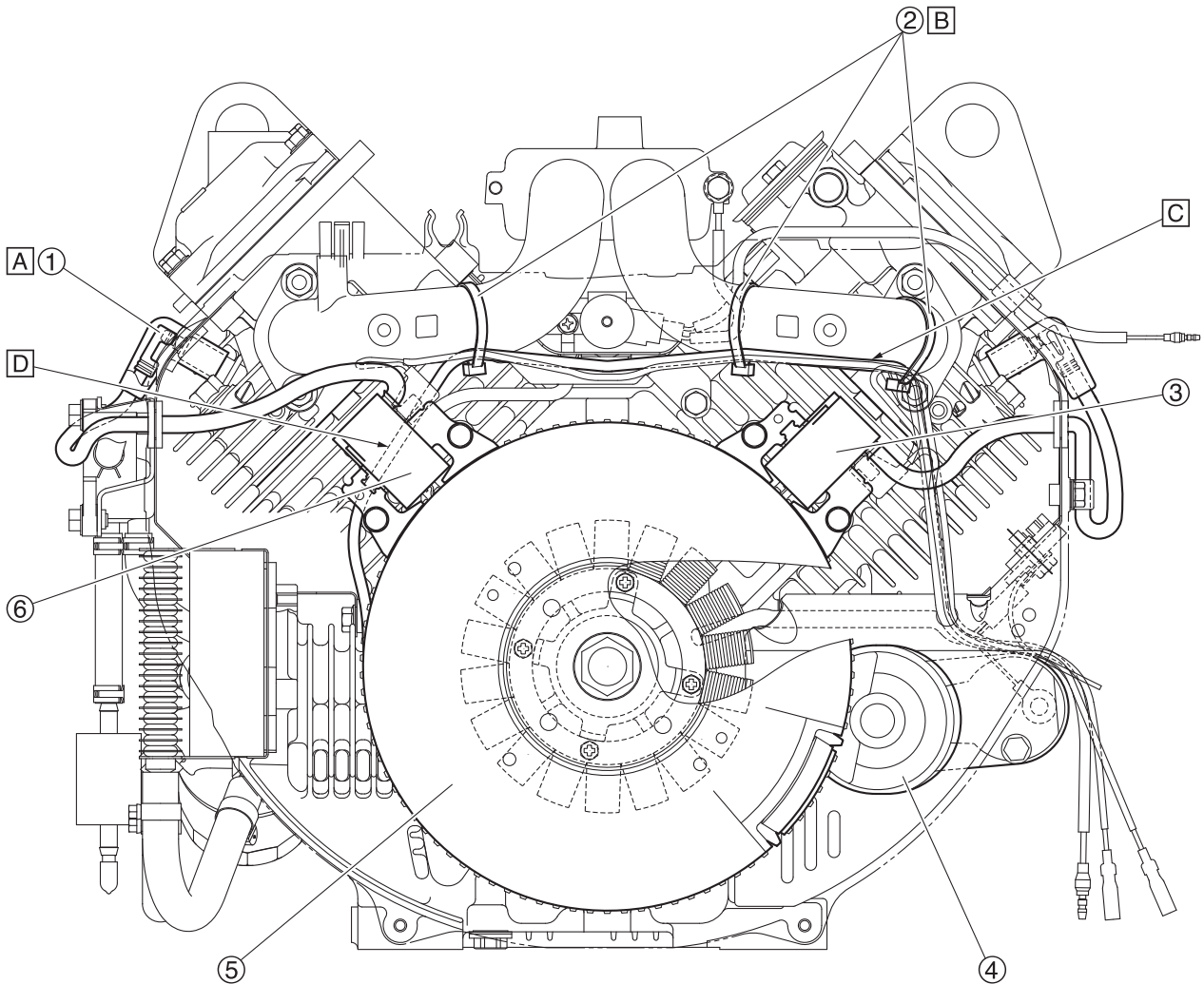

- 1. Terminal
- 2. Plastic locking tie
- 3. TCI unit #1

- 4. Starter motor
- 5. Flywheel
- 6. TCI unit #2

- A. For the terminal, install the spark plug cap after caulking to the high tension cord.
- B. Position the lock portion on the lower side of the intake manifold. Cut the extra portion plastic locking tie so that projection is 0 mm (0 in).
- C. There should be no looseness or tightness of the lead. Adjustment before and after the plastic locking tie.
- D. Route over the TCI unit mount.

WIRE ROUTING DIAGRAM

TCI UNIT (EH72K, EXCEPT FOR CHN)

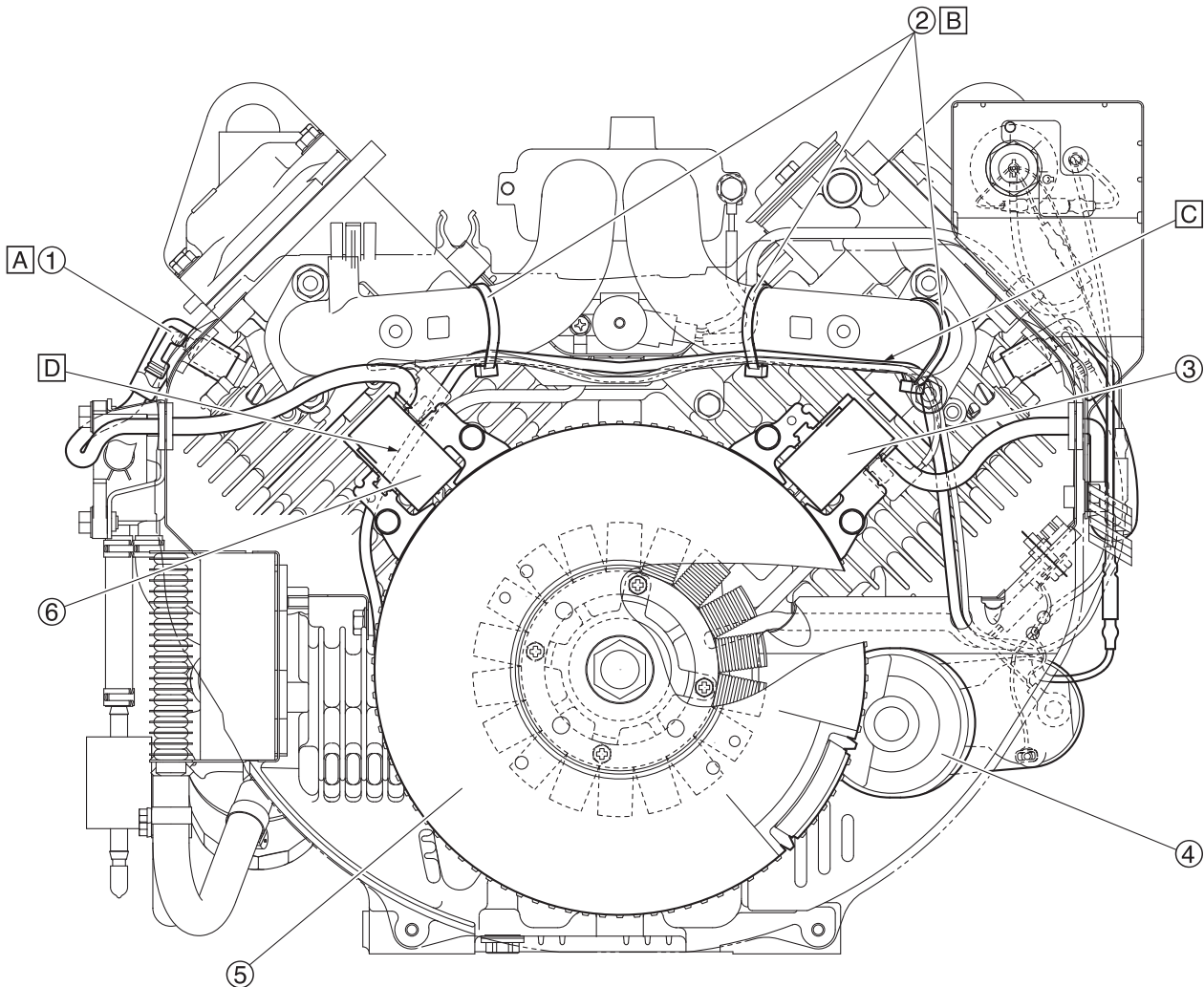

- 1. Terminal
- 2. Plastic locking tie
- 3. TCI unit #1
- 4. Starter motor
- 5. Flywheel
- 6. TCI unit #2

- A. For the terminal, install the spark plug cap after caulking to the high tension cord.
- B. Position the lock portion on the lower side of the intake manifold. Cut the extra portion plastic locking tie so that projection is 0 mm (0 in).
- C. There should be no looseness or tightness of the lead. Adjustment before and after the plastic locking tie.
- D. Route over the TCI unit mount.

WIRE ROUTING DIAGRAM

RECTIFIER/REGULATOR AND STARTER MOTOR (EH63K)

7
SPECIFICATIONS

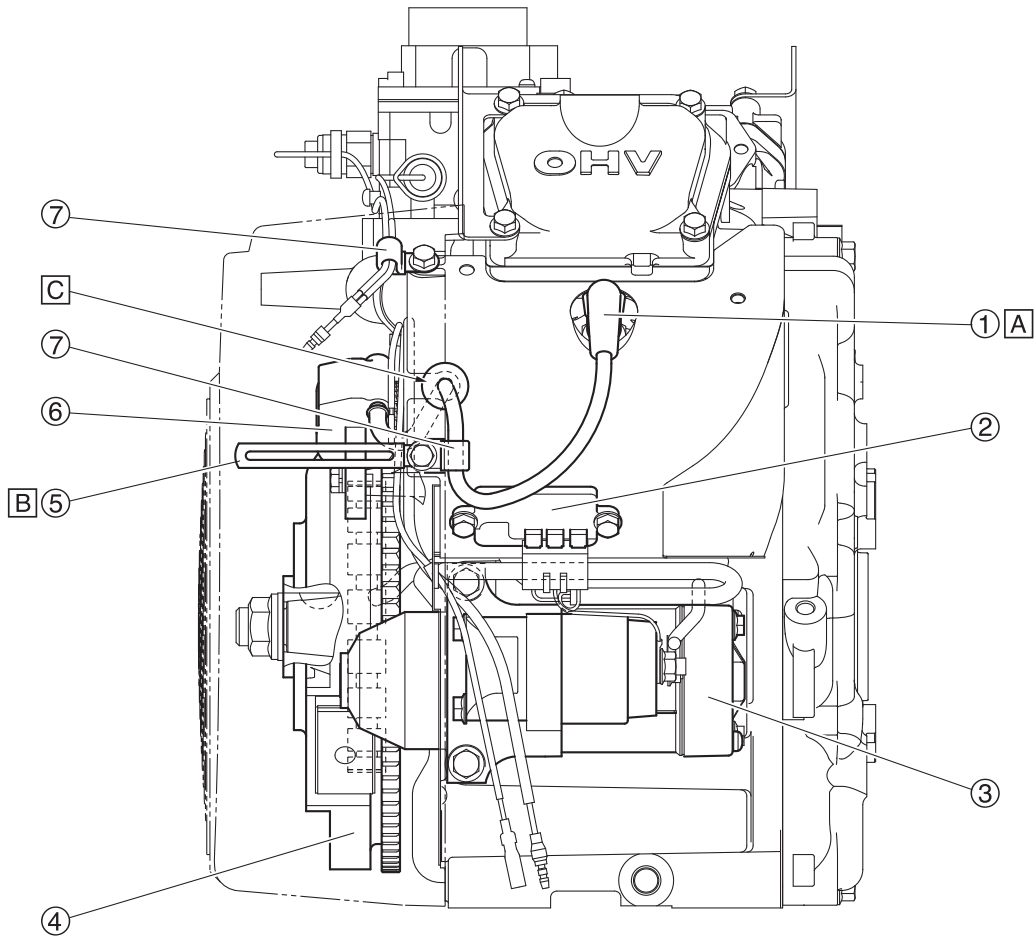

- | | |
|------------------------|----------------|
| 1. Spark plug cap | 5. Clamp 2 |
| 2. Rectifier/regulator | 6. TCI unit #1 |
| 3. Starter motor | 7. Clamp 1 |
| 4. Flywheel | |
- A. Point the spark plug cap in the direction shown in the illustration.
B. Install this part to the inside of the engine body than the clamp 1.
C. Install the grommet all the way to the back of the fan case groove.

WIRE ROUTING DIAGRAM

RECTIFIER/REGULATOR AND STARTER MOTOR (EH64A)

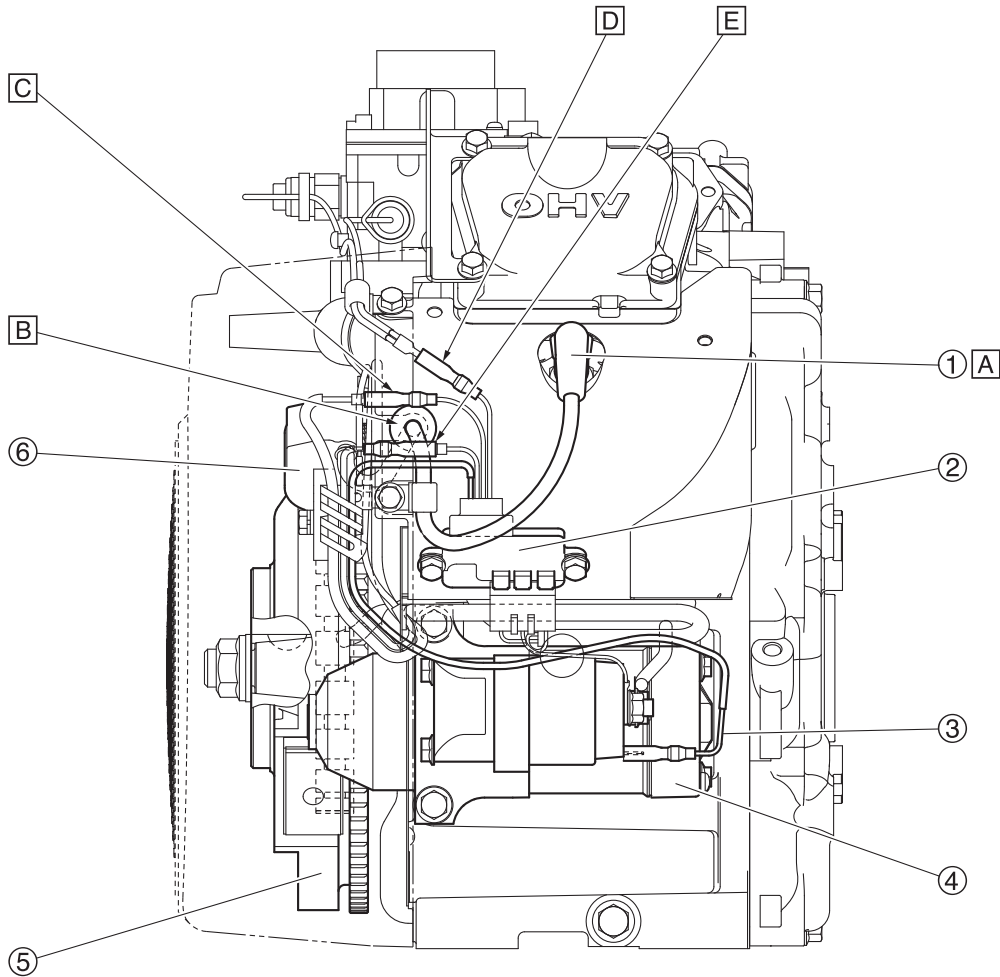

- | | |
|-------------------------|------------------|
| 1. Spark plug cap | 4. Starter motor |
| 2. Rectifier/regulator | 5. Flywheel |
| 3. Connector lead (Red) | 6. TCI unit #1 |
-
- A. Point the spark plug cap in the direction shown in the illustration.
 - B. Install the grommet all the way to the back of the fan case groove.
 - C. Connect wire lead terminal to yellow lead.
 - D. Connect wire lead terminal to red lead.
 - E. Connect wire lead 1 terminal to black/white lead.

WIRE ROUTING DIAGRAM

RECTIFIER/REGULATOR AND STARTER MOTOR (EH64K, EXCEPT FOR KOR)

7
SPECIFICATIONS

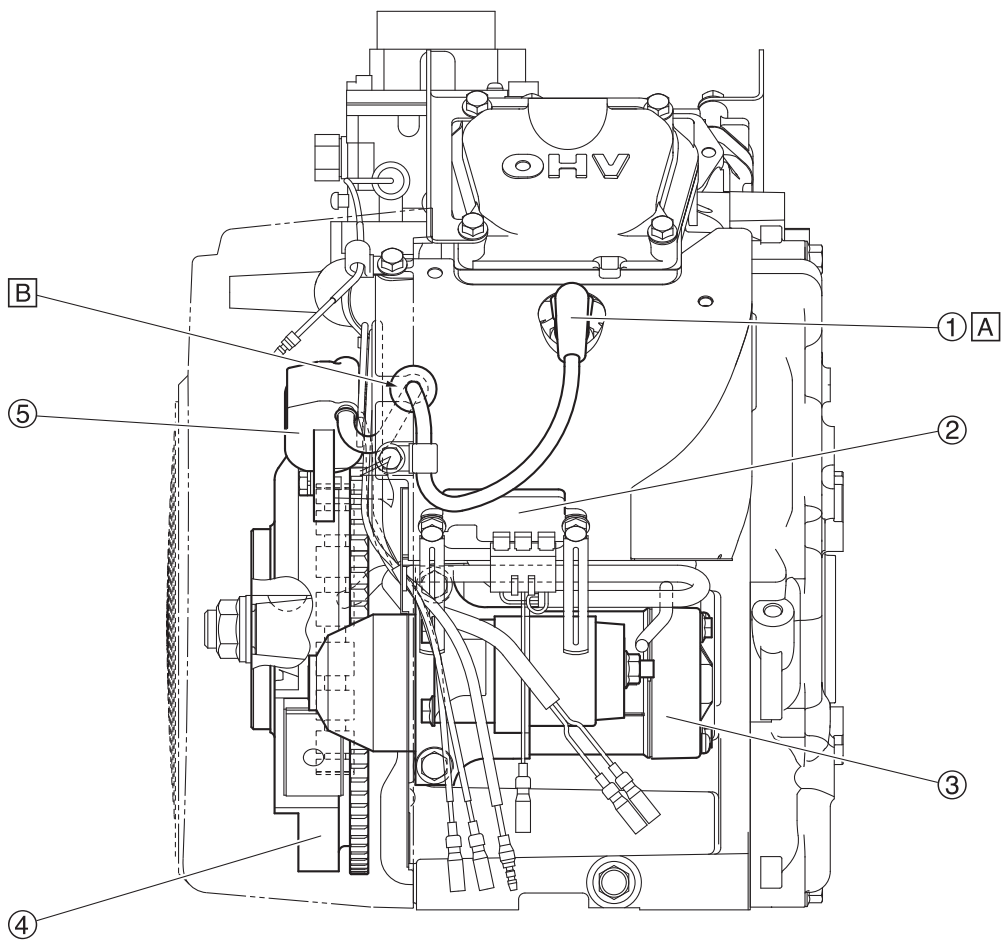

- 1. Spark plug cap
- 2. Rectifier/regulator
- 3. Starter motor
- 4. Flywheel
- 5. TCI unit #1

- A. Point the spark plug cap in the direction shown in the illustration.
- B. Install the grommet all the way to the back of the fan case groove.

WIRE ROUTING DIAGRAM

RECTIFIER/REGULATOR AND STARTER MOTOR (EH64K, FOR KOR)

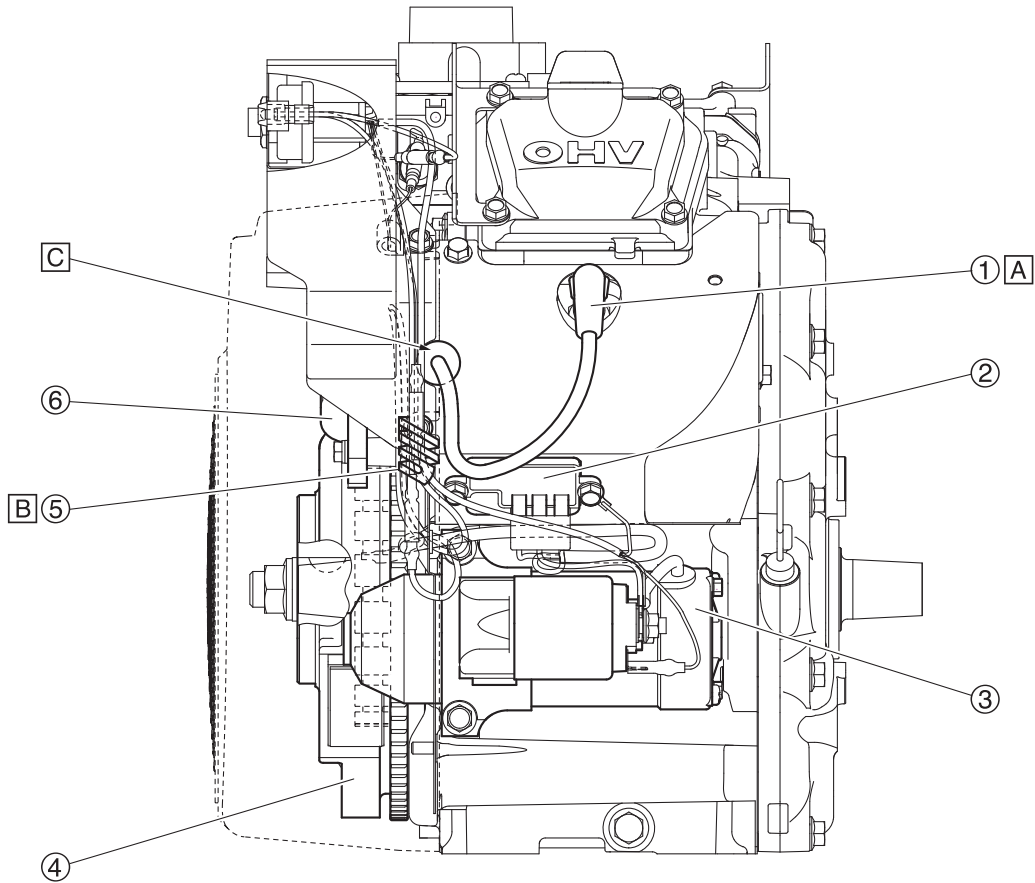

- | | |
|------------------------|----------------|
| 1. Spark plug cap | 4. Flywheel |
| 2. Rectifier/regulator | 5. Clamp |
| 3. Starter motor | 6. TCI unit #1 |

- A. Point the spark plug cap in the direction shown in the illustration.
- B. Bundle 1.5 or more volumes other than the wire of the carburetor.
- C. Install the grommet all the way to the back of the fan case groove.

WIRE ROUTING DIAGRAM

RECTIFIER/REGULATOR AND STARTER MOTOR (EH65A)

7
SPECIFICATIONS

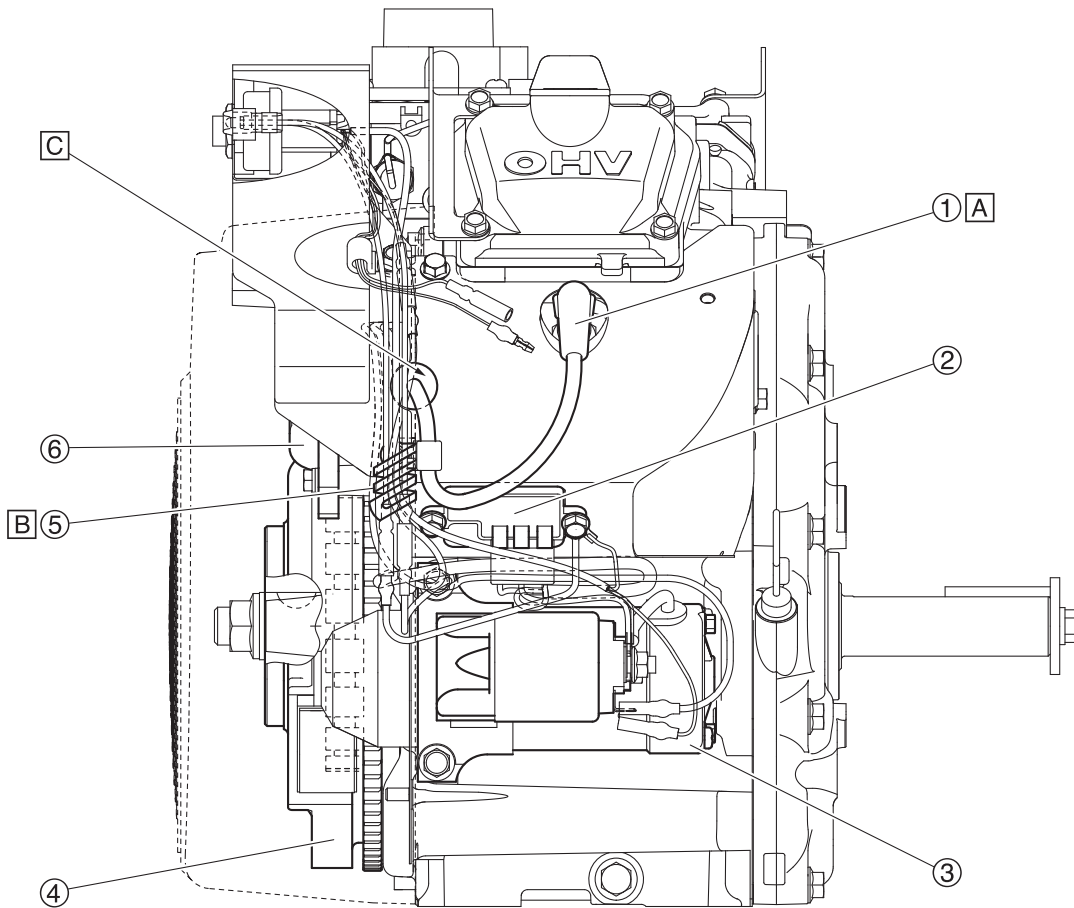

- | | |
|------------------------|----------------|
| 1. Spark plug cap | 4. Flywheel |
| 2. Rectifier/regulator | 5. Clamp |
| 3. Starter motor | 6. TCI unit #1 |
- A. Point the spark plug cap in the direction shown in the illustration.
B. Bundle 1.5 or more volumes other than the wire of the carburetor.
C. Install the grommet all the way to the back of the fan case groove.

WIRE ROUTING DIAGRAM

RECTIFIER/REGULATOR AND STARTER MOTOR (EH65B)

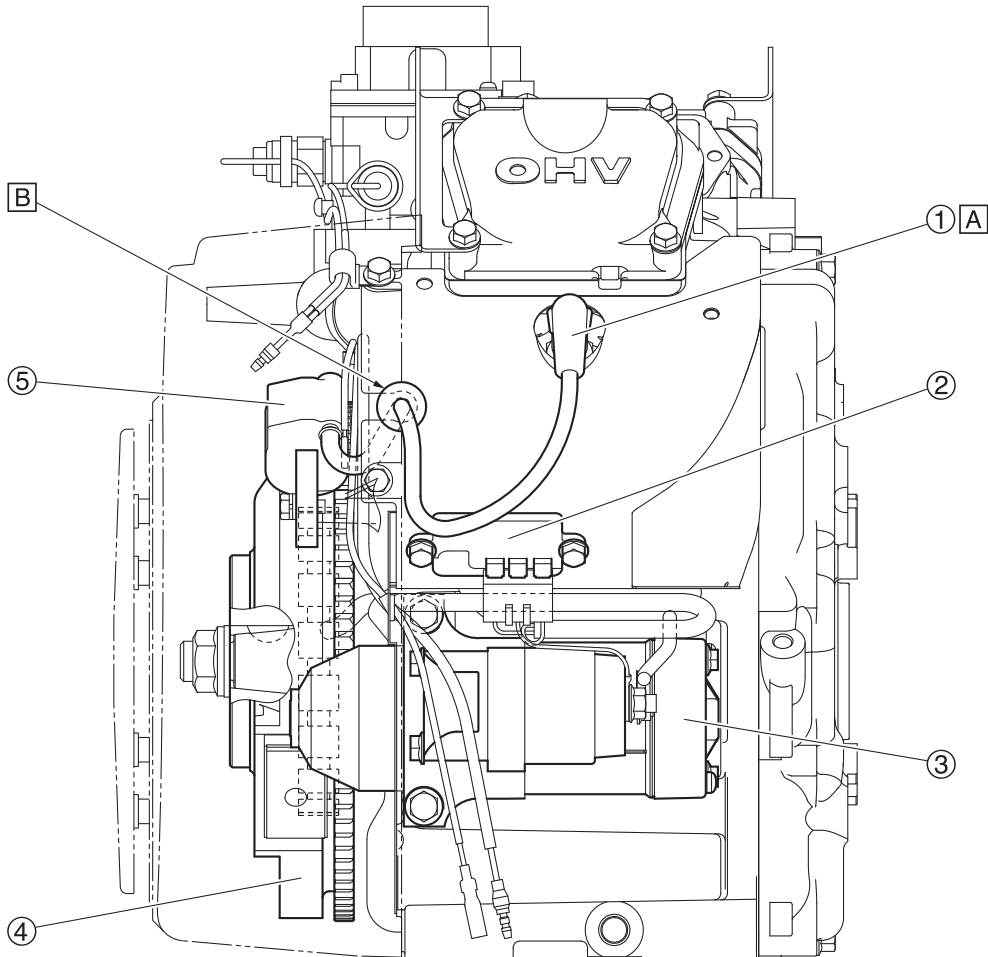

- 1. Spark plug cap
- 2. Rectifier/regulator
- 3. Starter motor
- 4. Flywheel
- 5. TCI unit #1

- A. Point the spark plug cap in the direction shown in the illustration.
- B. Install the grommet all the way to the back of the fan case groove.

WIRE ROUTING DIAGRAM

RECTIFIER/REGULATOR AND STARTER MOTOR (EH72A)

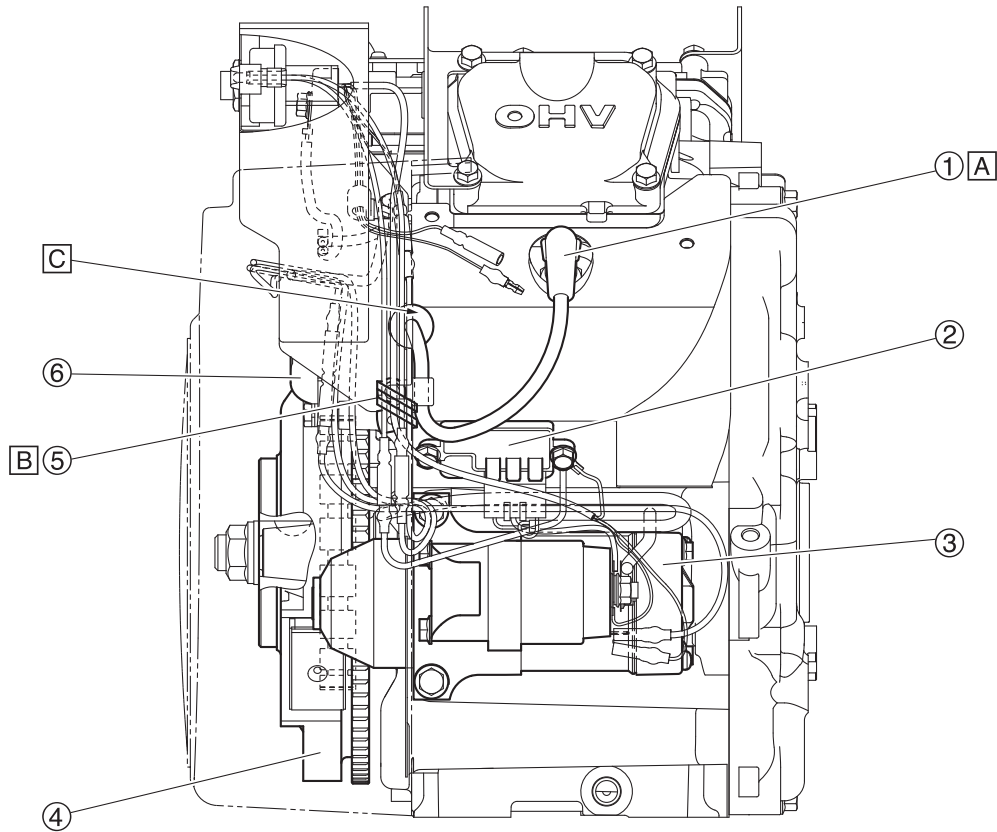

- 1. Spark plug cap
- 2. Rectifier/regulator
- 3. Starter motor
- 4. Flywheel
- 5. Clamp
- 6. TCI unit #1

- A. Point the spark plug cap in the direction shown in the illustration.
- B. Bundle 1.5 or more volumes other than the wire of the carburetor.
- C. Install the grommet all the way to the back of the fan case groove.

WIRE ROUTING DIAGRAM

RECTIFIER/REGULATOR AND STARTER MOTOR (EH72B, FOR SEA/EH72K, FOR CHN)

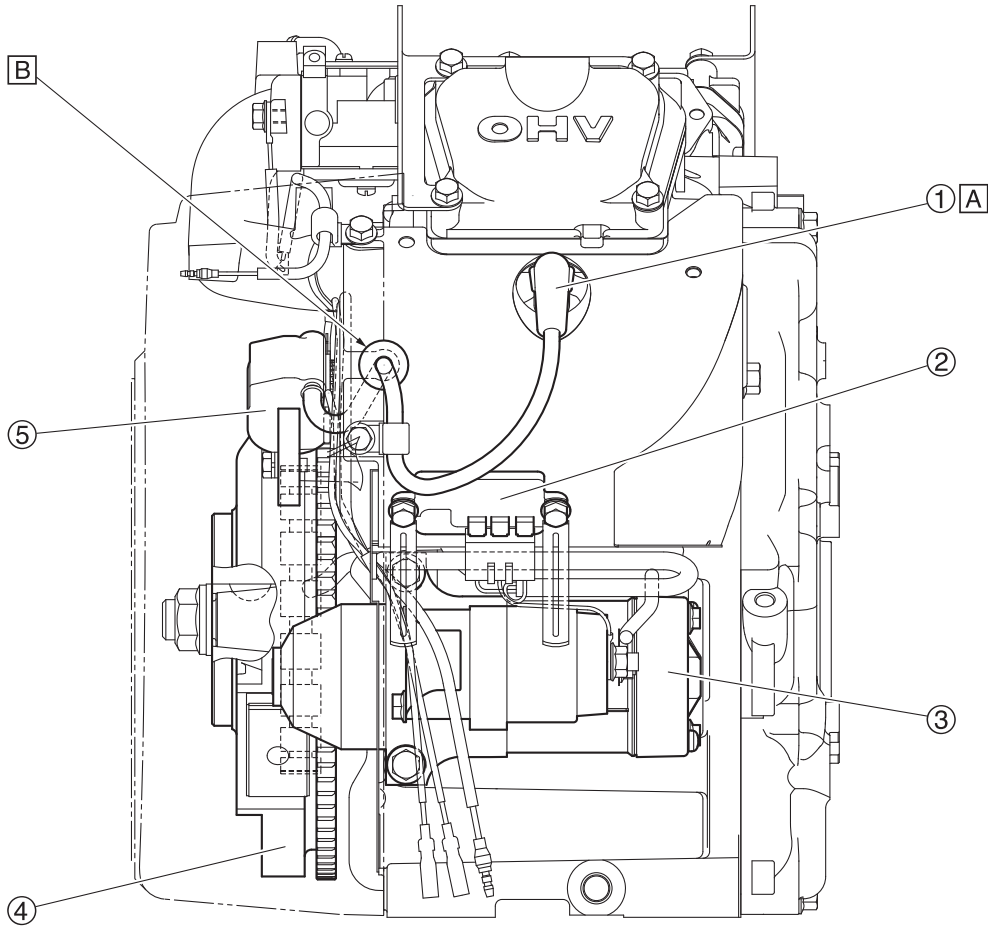

- 1. Spark plug cap
- 2. Rectifier/regulator
- 3. Starter motor
- 4. Flywheel
- 5. TCI unit #1

- A. Point the spark plug cap in the direction shown in the illustration.
- B. Install the grommet all the way to the back of the fan case groove.

WIRE ROUTING DIAGRAM

RECTIFIER/REGULATOR AND STARTER MOTOR (EH72K, EXCEPT FOR CHN)

7
SPECIFICATIONS

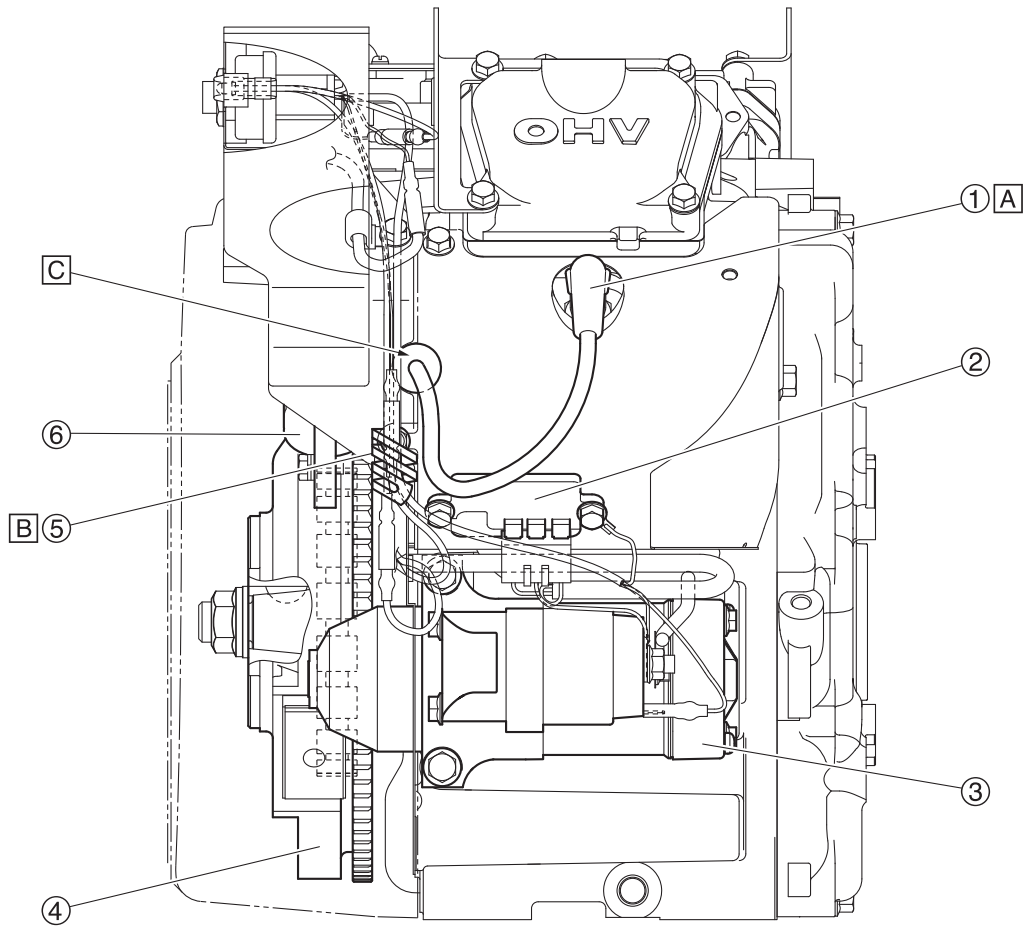

- | | |
|------------------------|----------------|
| 1. Spark plug cap | 4. Flywheel |
| 2. Rectifier/regulator | 5. Clamp |
| 3. Starter motor | 6. TCI unit #1 |
- A. Point the spark plug cap in the direction shown in the illustration.
B. Bundle 1.5 or more volumes other than the wire of the carburetor.
C. Install the grommet all the way to the back of the fan case groove.

MEMO

APPENDIX

CIRCUIT DIAGRAM

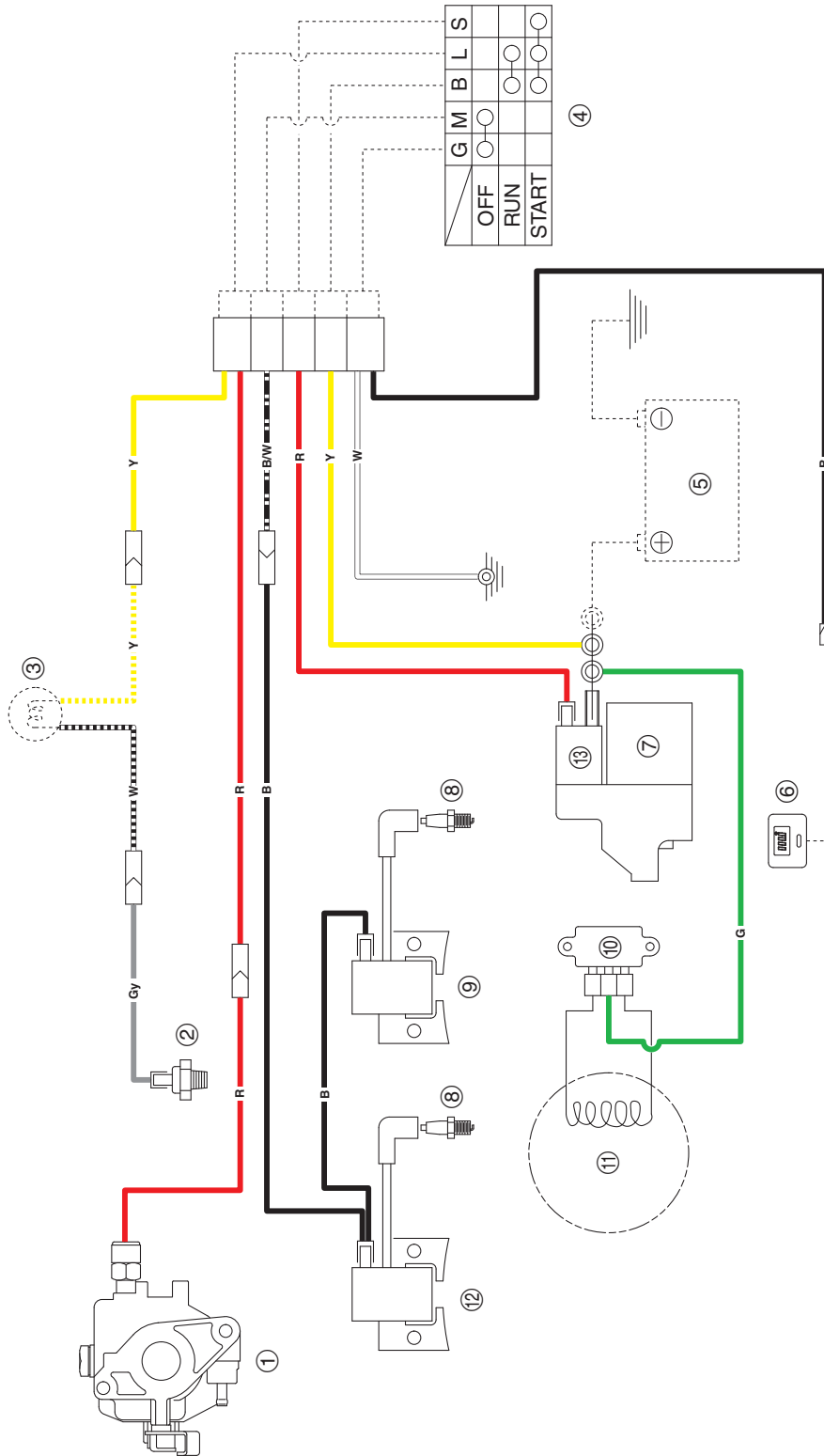

-
1. Carburetor
 2. Oil pressure switch
 3. Oil warning light (for equipped models)
 4. Engine switch (for equipped models)
 5. Battery (12 V, option)
 6. Tachometer/hour meter (option)
 7. Starter motor
 8. Spark plug
 9. TCI unit #1
 10. Rectifier/regulator
 11. Stator coil assembly
 12. TCI unit #2
 13. Starter relay

Color code

B	Black	W	White
G	Green	Gy	Gray
R	Red	B/W	Black/White
Y	Yellow		

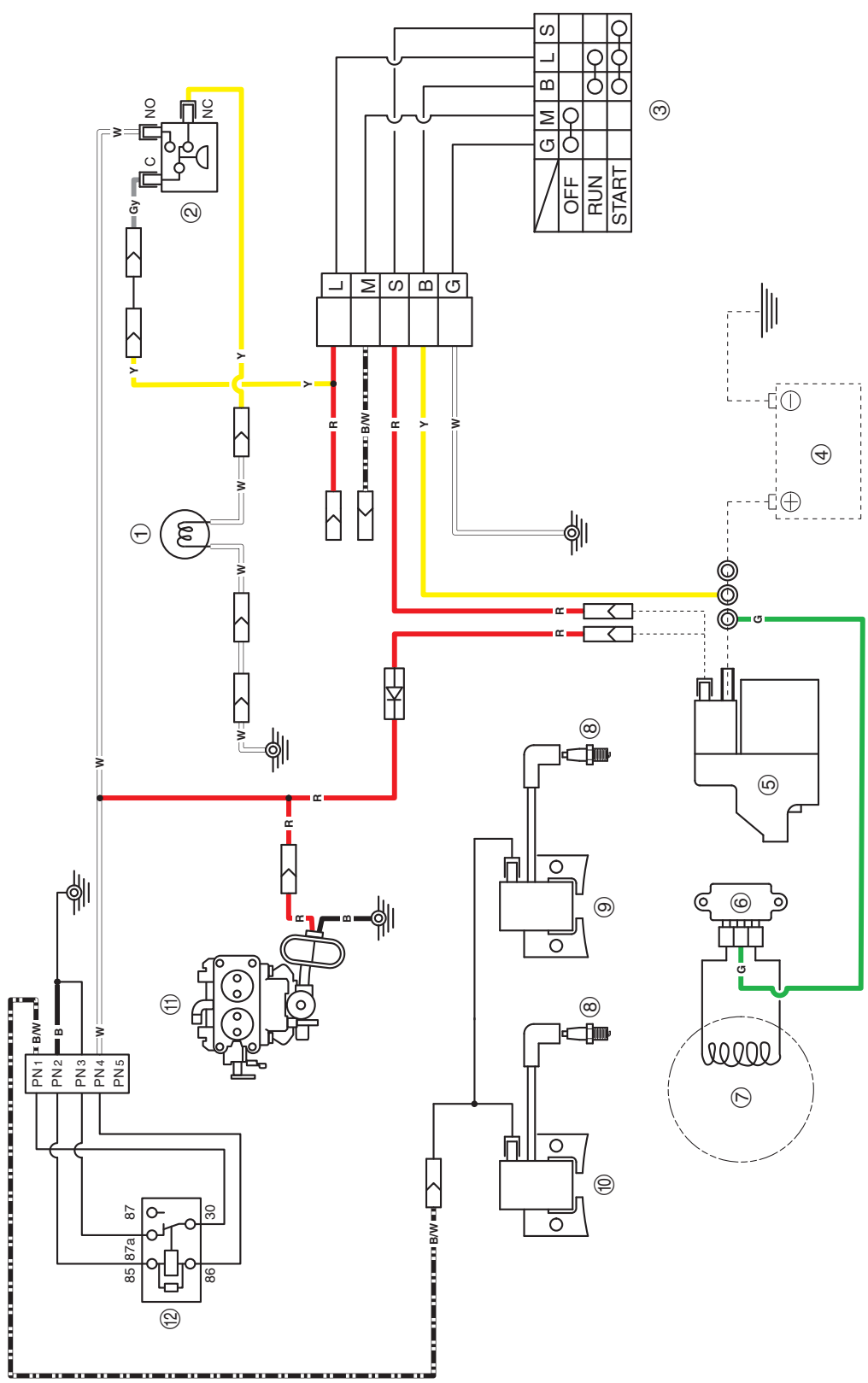

	G	M	B	L	S
OFF	○	○	○	○	○
RUN	○	○	○	○	○
START	○	○	○	○	○

-
1. Oil warning lamp
 2. Oil pressure switch
 3. Engine switch
 4. Battery
 5. Starter motor
 6. Rectifier/regulator

7. Starter assembly
8. Spark plug
9. Ignition coil #1
10. Ignition coil #2
11. Carburetor
12. Relay

Color code

B	Black	W	White
G	Green	Gy	Gray
R	Red	B/W	Black/White
Y	Yellow		

MEMO

