



PARTS CATALOGUE

MX360BA6A0 (7HC2) CHN,SEA

MX360C46A5 (7HC3) SEA

MX360AA6A0 (7HCJ) AFR,CSA,EUR,SEA

MX360A46A5 (7HCJ) CSA,SEA



1P7HC-400E1

()

2017/12/25

NEWS NO.	DATE	COMMENT
PE0-MP-170004	Dec.,19,2017	MOD:FIG.12 FUEL TANK LIST/ILLUSTRATION REVISION

MX360BA6A0/MX360C46A5
MX360AA6A0/MX360A46A5
PARTS CATALOGUE
©2015 by Yamaha Motor Co., Ltd.
1st edition, September 2015
All rights reserved.
Any reprinting or unauthorized use
without the written permission of
Yamaha Motor Co., Ltd.
is expressly prohibited.
Printed in Japan.

FOREWORD

This Parts Catalogue is related to the parts for the model(s) on the cover page. When you are ordering replacement parts, please refer to this Parts Catalogue and quote both part numbers and part names correctly.

1. Modifications or additions which have been made after the issue of the Parts Catalogue will be announced in the Parts News.

It is advisable that you make the necessary corrections to the Parts Catalogue according to the Parts News.

2. Abbreviations

The following abbreviations are used in this Parts Catalogue.

“UR” Use specified parts number.

“UN” Use as many as needed.

“AP” Alternate Parts

“LM” Locally Made (Parts need to be ordered locally)

“F#” Frame No. (Applicable machine No.)

“O/S” Over Size

3. The number of components for assembly

- Parts, which are to be supplied in an assembly, are listed with a dot (.) in front of the part name as shown below.
- The numeral appearing to the right of each component part indicates the quantity of parts for each assembly unit.

PART NO.	DESCRIPTION	Q'TY	REMARKS
2F5-83310-60	FRONT FLASHER LIGHT ASSY	2	
115-83311-60	.BULB (6V-18W)	1	

4. Applicable colours of graphics are represented in the “REMARKS” as shown below.

PART NO.	DESCRIPTION	Q'TY	REMARKS
2N4-24110-00-X5	FUEL TANK COMP.	2	MXR
3J1-24240-10	.GRAPHIC, FUEL TANK	1	FOR MXR

5. Note that the illustrations for reference in finding parts numbers are not to be used for assembling. When assembling, please use the applicable service manual.

6. The asterisk (*) before a reference number indicates modified items after the first edition.

FOREWORD

Engine Serial No.

This parts catalogue is related to the parts for the models in the list below.

MODEL CODE	MODEL NAME	SPECIFICATION (OUT LINE)	ENGINE SERIAL NO.
7HC2	MX360BA6A0	P.T.O. SHAFT B TYPE, MOUNT FACE (mm)	7HC2-1000101
7HC3	MZ360C46A5	P.T.O. SHAFT C TYPE, MOUNT FACE (mm)	7HC3-1000101
7HCJ	MX360AA6A0	P.T.O. SHAFT A TYPE, MOUNT FACE (UNF)	7HCJ-1000101
7HCJ	MX360A46A5	P.T.O. SHAFT A TYPE, MOUNT FACE (UNF)	7HCJ-2000101

CONTENTS

CYLINDER	1
CRANKSHAFT	2
CRANKSHAFT & PISTON	3
GOVERNOR 1	4
GOVERNOR 2	5
CAMSHAFT & VALVE	6
AIR SHROUD & STARTER	7
INTAKE	8
CARBURETOR	9
EXHAUST	10
CRANKCASE	11
FUEL TANK	12
TCI MAGNETO	14
ELECTRICAL	15
BODY FITTING	16
EMBLEM & LABEL	17

INDEX

NUMERICAL INDEX	18
-----------------------	----

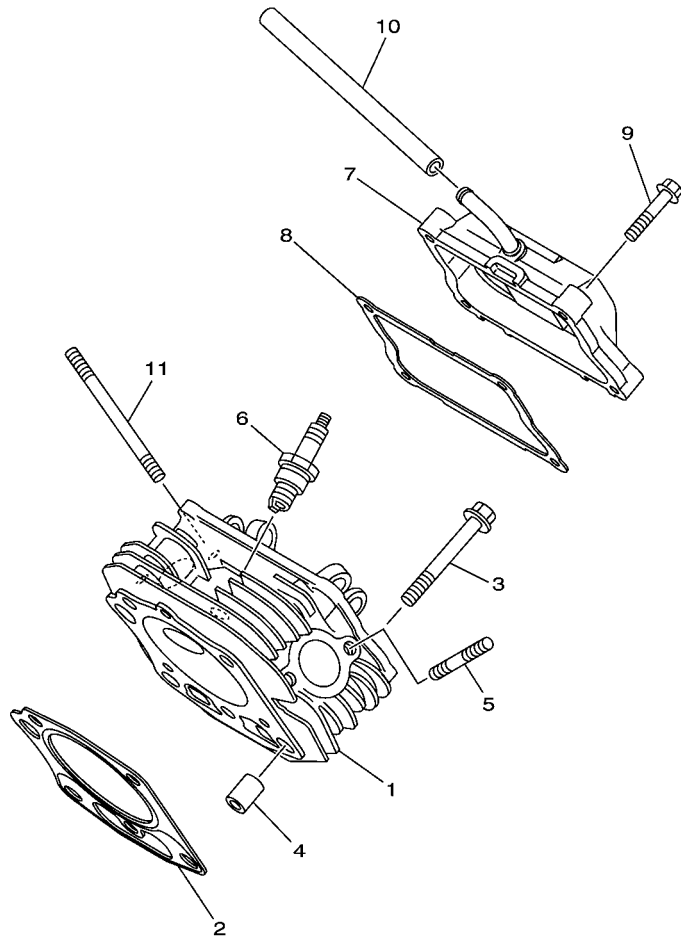
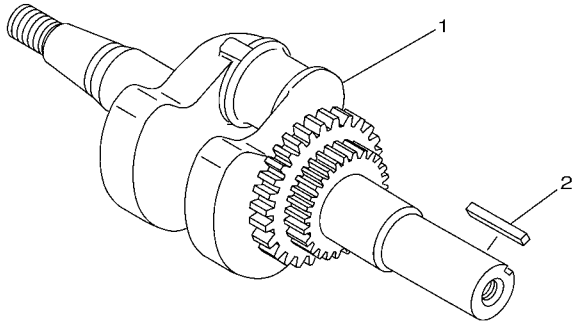
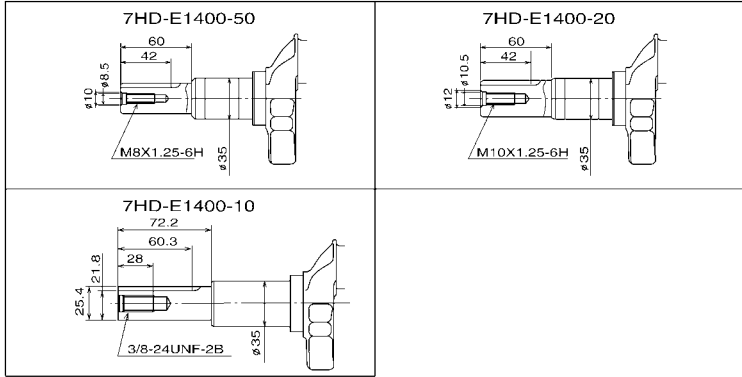

FIG. 1 CYLINDER

REF. NO.	PART NO.	DESCRIPTION	7HC2	7HC3	7HCJ			REMARKS
1	7HD-E1111-10	HEAD, CYLINDER 1	1	1	1			
2	7HD-E1181-00	GASKET, CYLINDER HEAD 1	1	1	1			
3	95812-10070	BOLT, FLANGE	5	5	5			
4	99530-14016	PIN, DOWEL	2	2	2			
5	95622-08618	BOLT, STUD	2	2	2			
6	94702-00819	PLUG, SPARK (NGK BPR4ES)	1	1	1			
7	7HD-E1190-10	COVER, CYLINDER HEAD 1	1	1	1			
8	7HD-E1193-00	GASKET, HEAD COVER 1	1	1	1			
9	95822-06030	BOLT, FLANGE	4	4	4			
10	7CT-E1166-00	PIPE, BREATHER 1	1	1	1			
11	95602-08710	BOLT, STUD	2	2	2			



 7P62110-N010



 7HC2400-P020

FIG. 2 CRANKSHAFT

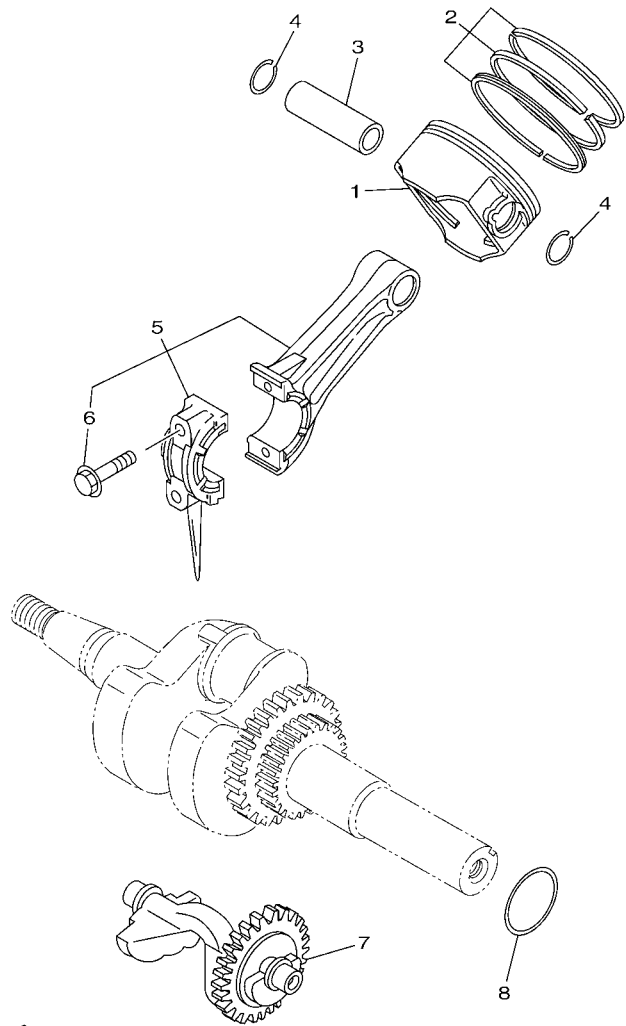
REF. NO.	PART NO.	DESCRIPTION	7HC2	7HC3	7HCJ	REMARKS
1	7HD-E1400-50	CRANKSHAFT ASSY	1			
	7HD-E1400-20	CRANKSHAFT ASSY		1		
	7HD-E1400-10	CRANKSHAFT ASSY			1	
2	90282-07061	KEY, STRAIGHT (7.0 MM)	1	1		
	90282-06037	KEY, STRAIGHT (6.3 MM)			1	



7HCJ110-P030

FIG. 3 CRANKSHAFT & PISTON

REF. NO.	PART NO.	DESCRIPTION	7HC2	7HC3	7HCJ	REMARKS
1	7HD-E1631-00-A0	PISTON (STD)	1	1	1	
	7HD-E1635-00	PISTON (0.25MM O/S)	1	1	1	AP
	7HD-E1636-00	PISTON (0.50MM O/S)	1	1	1	AP
2	7HD-E1610-00	PISTON RING SET (STD)	1	1	1	
	7HD-E1610-10	PISTON RING SET (0.25MM O/S)	1	1	1	AP
	7HD-E1610-20	PISTON RING SET (0.50MM O/S)	1	1	1	AP
3	7HD-E1633-00	PIN, PISTON	1	1	1	
4	93450-22840	CIRCLIP	2	2	2	
5	7HD-E1650-01	CONNECTING ROD ASSY	1	1	1	
6	7CT-E1654-00	.BOLT, CONNECTING ROD	2	2	2	
7	7CT-E1454-00	WEIGHT 1	1	1	1	
8	7CT-E1561-00	SHIM, CRANK 1	1	1	1	UN
<hr style="border-top: 1px dashed black;"/>						
<hr style="border-top: 1px dashed black;"/>						
<hr style="border-top: 1px dashed black;"/>						
<hr style="border-top: 1px dashed black;"/>						
<hr style="border-top: 1px dashed black;"/>						

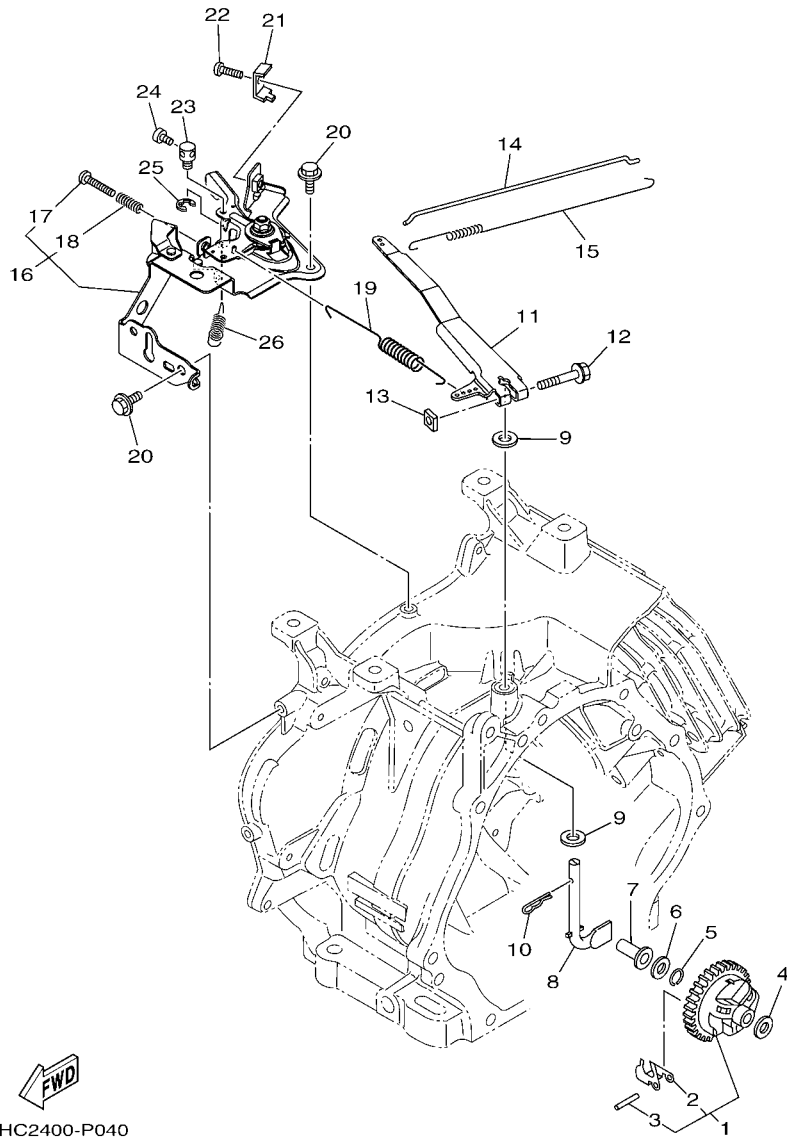
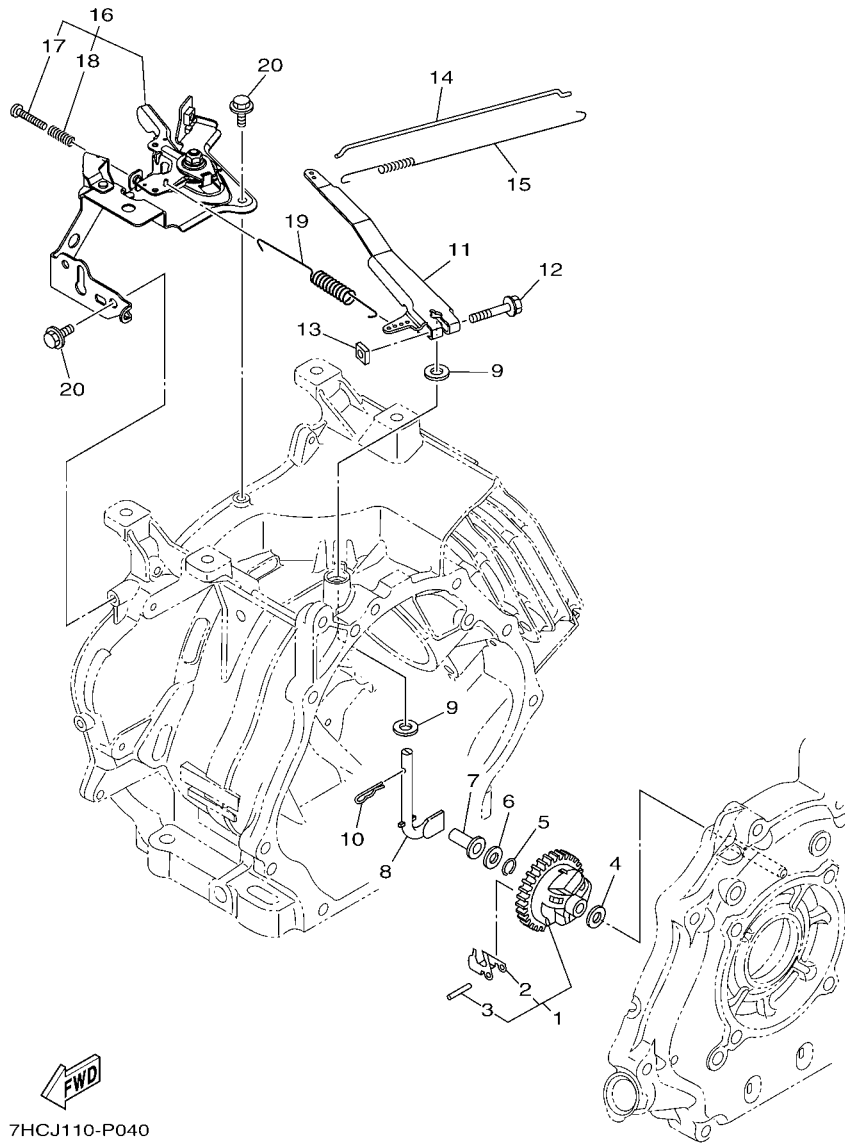

FIG. 4 GOVERNOR 1

REF. NO.	PART NO.	DESCRIPTION	7HC2	7HC3	7HCJ	REMARKS
1	7CT-E1970-10	FLYWEIGHT SHAFT ASSY	1			
2	7CT-E1913-00	.WEIGHT	3			
3	7CT-E1914-00	.SHAFT, WEIGHT	3			
4	90201-06842	WASHER, PLATE	1			
5	93440-06826	CIRCLIP	1			
6	90201-067L0	WASHER, PLATE	1			
7	7CT-E1917-00	COLLAR	1			
8	7CT-E1922-00	FORK, GOVERNOR	1			
9	90201-08858	WASHER, PLATE	2			
10	90468-12801	CLIP	1			
11	7HC-E1924-10	ARM, GOVERNOR	1			
12	97522-06530	BOLT, WITH WASHER	1			
13	90173-06802	NUT, SQUARE	1			
14	7HC-E1928-00	ROD, LINK	1			
15	90506-04006	SPRING, TENSION	1			
16	7HC-G1240-00	THROTTLE LEVER COMP.	1			
17	98502-05025	.SCREW, PAN HEAD	1			
18	90501-090A8	.SPRING, COMPRESSION	1			
19	90506-14804	SPRING, TENSION	1			
20	95802-06012	BOLT, FLANGE	2			
21	7HC-E1933-00	PLATE, ADJUST	1			
22	98502-05016	SCREW, PAN HEAD	1			
23	7CT-E1932-00	SETTER, WIRE	1			
24	98502-04006	SCREW, PAN HEAD	1			
25	99001-04600	CIRCLIP	1			
26	90506-07412	SPRING, TENSION	1			



7HCJ110-P040

FIG. 5 GOVERNOR 2

REF. NO.	PART NO.	DESCRIPTION	7HC2	7HC3	7HCJ	REMARKS
1	7CT-E1970-10	FLYWEIGHT SHAFT ASSY		1	1	
2	7CT-E1913-00	.WEIGHT		3	3	
3	7CT-E1914-00	.SHAFT, WEIGHT		3	3	
4	90201-06842	WASHER, PLATE		1	1	
5	93440-06826	CIRCLIP		1	1	
6	90201-067L0	WASHER, PLATE		1	1	
7	7CT-E1917-00	COLLAR		1	1	
8	7CT-E1922-00	FORK, GOVERNOR		1	1	
9	90201-08858	WASHER, PLATE		2	2	
10	90468-12801	CLIP		1	1	
11	7HC-E1924-10	ARM, GOVERNOR		1	1	
12	97522-06530	BOLT, WITH WASHER		1	1	
13	90173-06802	NUT, SQUARE		1	1	
14	7HC-E1928-00	ROD, LINK		1	1	
15	90506-04006	SPRING, TENSION		1	1	
16	7HC-G1240-00	THROTTLE LEVER COMP.		1	1	
17	98502-05025	.SCREW, PAN HEAD		1	1	
18	90501-090A8	.SPRING, COMPRESSION		1	1	
19	90506-14804	SPRING, TENSION		1	1	
20	95802-06012	BOLT, FLANGE		2	2	

FIG. 6 CAMSHAFT & VALVE

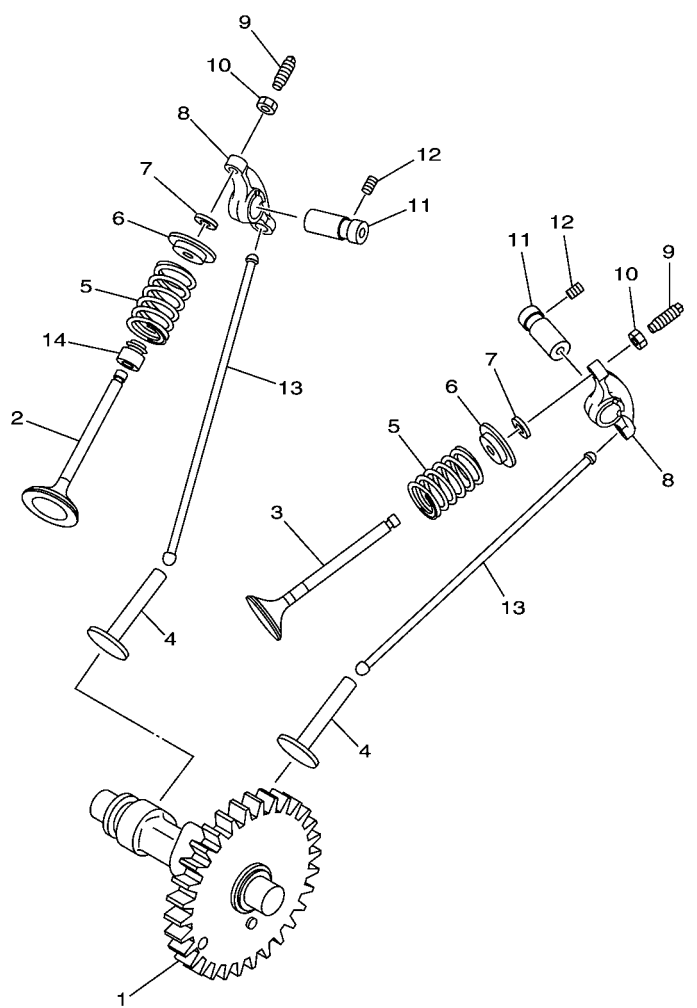

7P62110-N040

REF. NO.	PART NO.	DESCRIPTION	7HC2	7HC3	7HCJ	REMARKS
1	7HD-E2170-00	CAMSHAFT ASSY 1	1	1	1	
2	7CT-E2111-00	VALVE, INTAKE	1	1	1	
3	7HD-E2121-00	VALVE, EXHAUST	1	1	1	
4	7CT-E2153-00	LIFTER, VALVE	2	2	2	
5	90501-264A9	SPRING, COMPRESSION	2	2	2	
6	7CT-E2117-00	RETAINER, VALVE SPRING	2	2	2	
7	7CT-E2118-00	LOCK, VALVE SPRING RETAINER	2	2	2	
8	7CT-E2151-00	ARM, VALVE ROCKER	2	2	2	
9	7CT-E2159-00	SCREW, VALVE ADJUSTING	2	2	2	
10	90170-05806	NUT	2	2	2	
11	7HD-E2156-00	SHAFT, ROCKER 2	2	2	2	
12	90113-05800	BOLT, SET	2	2	2	
13	7HD-E2154-00	ROD, VALVE PUSH	2	2	2	
14	7CT-E2119-00	SEAL, VALVE STEM	1	1	1	

FIG. 7 AIR SHROUD & STARTER

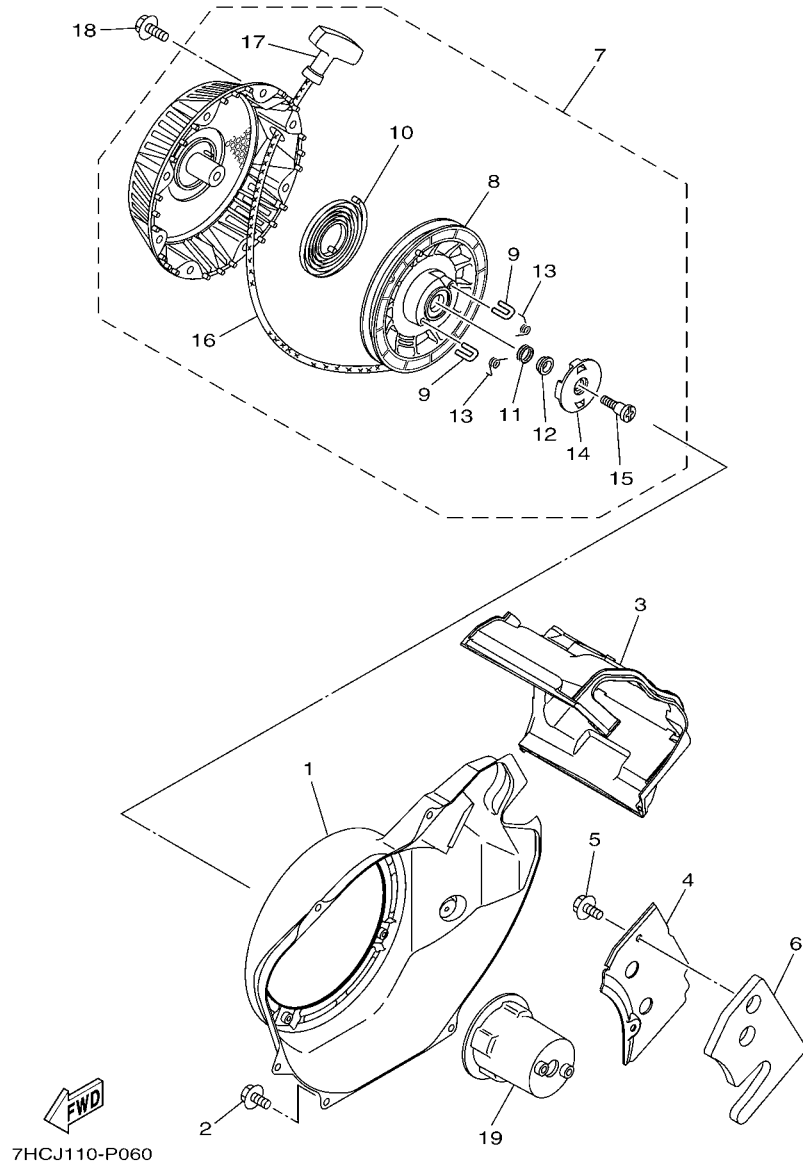

REF. NO.	PART NO.	DESCRIPTION	7HC2	7HC3	7HCJ	REMARKS
1	7HD-E2621-00	CASE, FAN	1	1	1	
2	95802-06012	BOLT, FLANGE	6	6		FOR MX360AA6A0
	95802-06012	BOLT, FLANGE		5	5	FOR MX360A46A5
3	7HC-E2651-00	AIR SHROUD, CYLINDER 1	1	1	1	
4	7HC-E2652-00	AIR SHROUD, CYLINDER 2	1	1	1	
5	95802-06012	BOLT, FLANGE	2	2	2	
6	7HD-E261H-00	SEAL 1	1	1	1	
7	7HC-E5710-00	STARTER ASSY	1	1	1	
8	7HC-E5714-00	.DRUM, SHEAVE	1	1	1	
9	7HC-E5741-00	.PAWL, DRIVE	2	2	2	
10	7HC-E5713-00	.SPRING, STARTER	1	1	1	
11	7HC-E5715-00	.SPRING, FRICTION	1	1	1	
12	7HC-E5719-00	.WASHER, THRUST	1	1	1	
13	7HC-E5743-00	.SPRING, RETURN	2	2	2	
14	7HC-E5716-00	.PLATE, DRIVE	1	1	1	
15	7HC-E5793-00	.SCREW	1	1	1	
16	7CT-E5751-00	.WIRE, STARTER	1	1	1	
17	7CN-E5755-00	.HANDLE, STARTER	1	1	1	
18	95802-06016	BOLT, FLANGE	4	4	4	
19	7HC-E5723-00	PULLEY, STARTER	1	1	1	

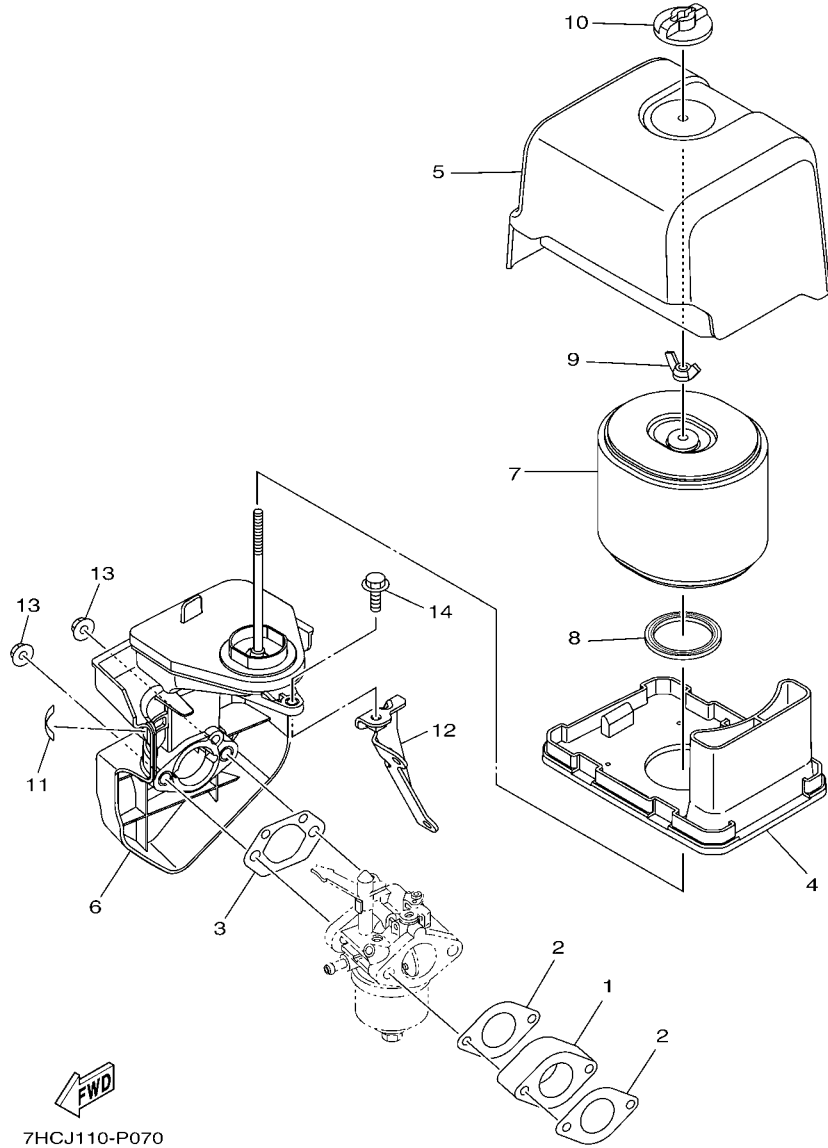
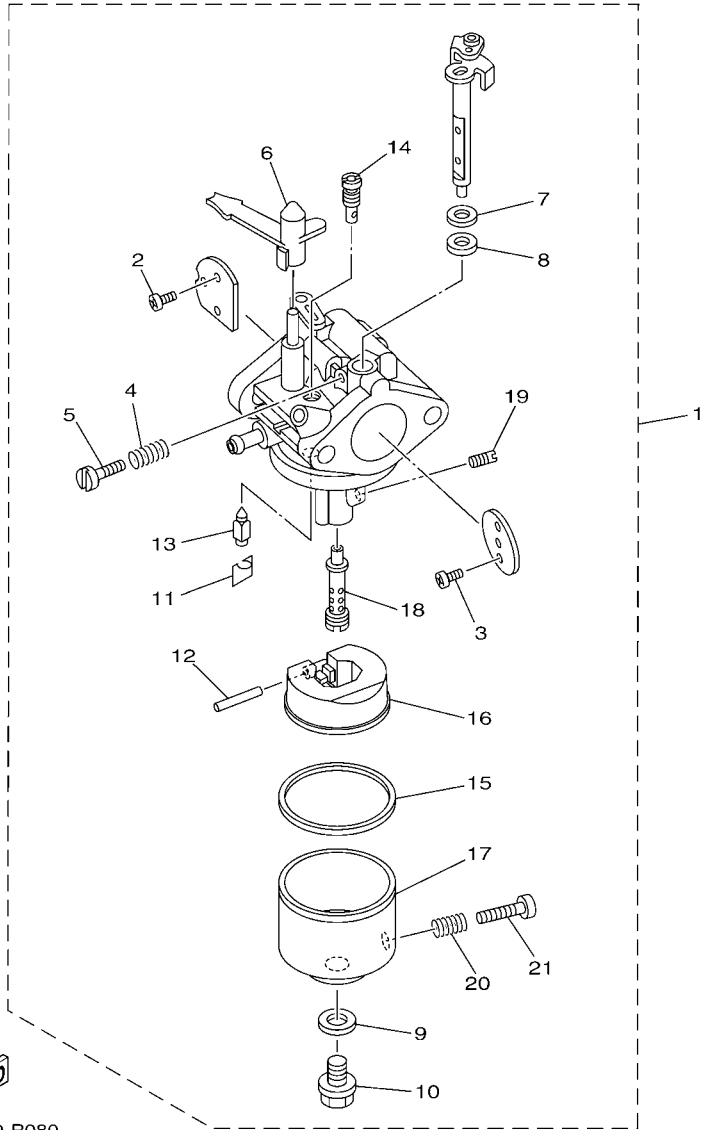

FIG. 8 INTAKE

REF. NO.	PART NO.	DESCRIPTION	7HC2	7HC3	7HCJ	REMARKS
1	7CT-E3596-00	JOINT, CARBURETOR 2	1	1	1	
2	7CT-E3557-00	GASKET	2	2	2	
3	7HC-E3567-00	GASKET	1	1	1	
4	7HC-E4411-00	CASE, AIR CLEANER 1	1	1	1	
5	7HC-E4412-00	CAP, CLEANER CASE 1	1	1	1	
6	7HC-E4430-00	DUCT ASSY	1	1	1	
7	7HC-E4450-00	ELEMENT ASSY, AIR CLEANER	1	1	1	
8	7HC-E4457-00	SEAL	1	1	1	
9	90175-06809	NUT, WING	1	1	1	
10	7HC-E4439-00	NUT	1	1	1	
11	7CN-F4155-00	INDICATOR, CHOKE	1	1	1	
12	7HC-E4499-00	STAY 2	1	1	1	
13	95702-08500	NUT, FLANGE	2	2	2	
14	95802-06016	BOLT, FLANGE	1	1	1	



7HC2400-P080

FIG. 9 CARBURETOR

REF. NO.	PART NO.	DESCRIPTION	7HC2	7HC3	7HCJ	REMARKS
1	7HC-E4301-20	CARBURETOR ASSY 1	1	1	1	
2	7BX-E4486-00	.SCREW, ROD	2	2	2	
3	7BX-E4216-00	.SCREW	2	2	2	
4	7BX-E4212-00	.SPRING, PILOT ADJUSTING	1	1	1	
5	7HC-E4922-00	.SCREW, THROTTLE	1	1	1	
6	7HC-E4583-00	.LEVER, CHOKE	1	1	1	
7	7HC-E4117-00	.WASHER, PLUG SCREW	1	1	1	
8	7HC-E4239-00	.SEAL	1	1	1	
9	7HC-E4227-00	.WASHER	1	1	1	
10	7HC-E4162-00	.BOLT, HOLDING	1	1	1	
11	7HC-E4159-00	.CLIP	1	1	1	
12	7BX-E4186-00	.PIN, FLOAT	1	1	1	
13	7HC-E4150-00	.NEEDLE ASSY	1	1	1	
14	7HC-E4A42-24	.JET, PILOT	1	1	1	
15	7HC-E4184-00	.GASKET, FLOAT CHAMBER	1	1	1	
16	7HC-E4185-00	.FLOAT	1	1	1	
17	7HC-E4A81-00	.BODY, FLOAT CHAMBER 1	1	1	1	
18	7HC-E4A41-00	.NOZZLE, MAIN	1	1	1	
19	7HC-E4A43-58	.JET, MAIN	1	1	1	
20	7BX-E4212-00	.SPRING, PILOT ADJUSTING	1	1	1	
21	7HC-E4191-00	.PLUG, DRAIN	1	1	1	

FIG. 10 EXHAUST

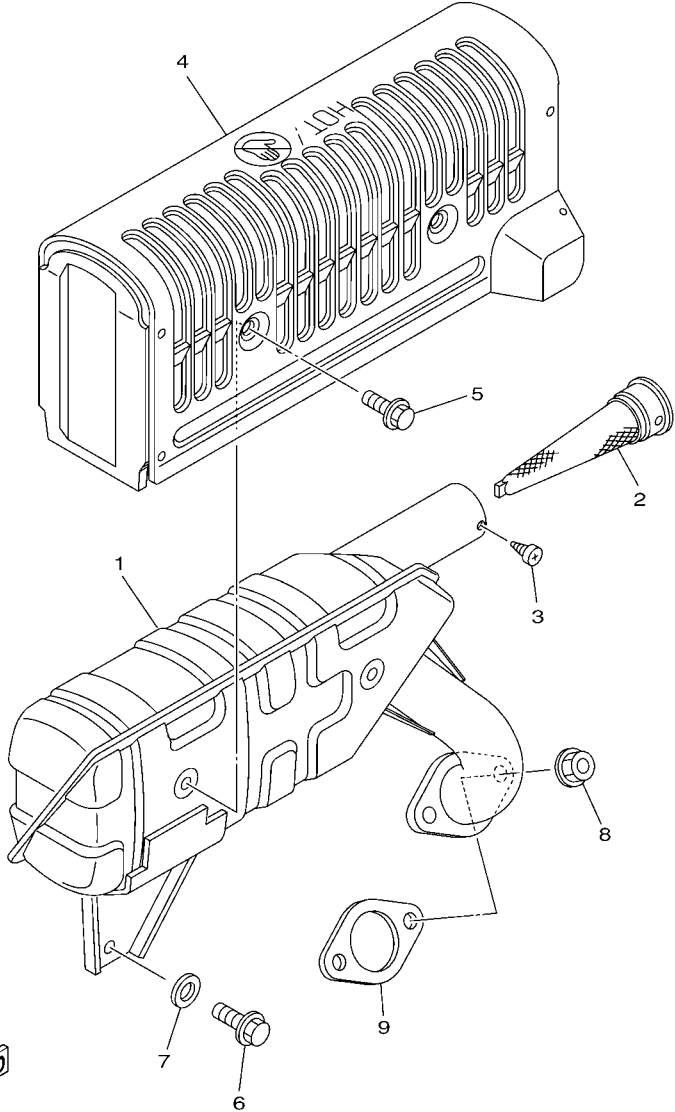

7HCJ110-P090

REF. NO.	PART NO.	DESCRIPTION	7HC2	7HC3	7HCJ	REMARKS
1	7HC-E4721-00	MUFFLER 2	1	1	1	
2	7BY-E4786-00	ARRESTER, SPARK	1	1	1	
3	97702-40506	SCREW, TAPPING	1	1	1	
4	7HC-E4708-00	PROTECTOR ASSY	1	1	1	
5	95822-06008	BOLT, FLANGE	4	4	4	
6	95822-08016	BOLT, FLANGE	1	1	1	
7	90201-08856	WASHER, PLATE	1	1	1	
8	95302-08600	NUT, HEXAGON	2	2	2	
9	7HC-E4613-00	GASKET, EXHAUST PIPE	1	1	1	

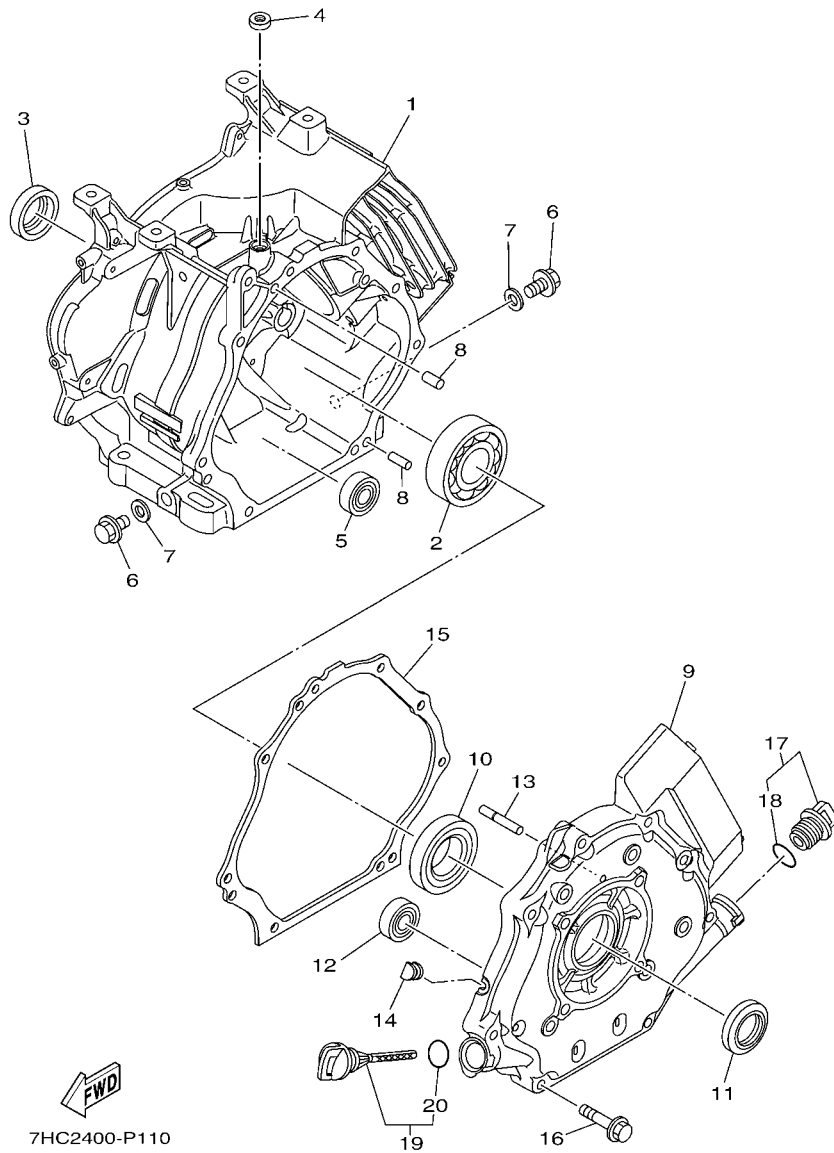

FIG. 11 CRANKCASE

REF. NO.	PART NO.	DESCRIPTION	7HC2	7HC3	7HCJ	REMARKS
1	7HC-E5111-00	CRANKCASE 1	1	1	1	
2	93306-307Y3	BEARING	1	1	1	
3	93102-35802	OIL SEAL	1	1	1	
4	93109-08803	OIL SEAL	1	1	1	
5	93306-252YK	BEARING	1	1	1	
6	90340-12097	PLUG, STRAIGHT SCREW	2	2	2	
7	7CT-E1198-00	GASKET	2	2	2	
8	99530-08016	PIN, DOWEL	2	2	2	
9	7HC-E5411-10	COVER, CRANKCASE 1	1	1		
	7HC-E5411-00	COVER, CRANKCASE 1			1	
10	93306-207Y2	BEARING	1	1	1	
11	93102-35802	OIL SEAL	1	1	1	
12	93306-252YK	BEARING	1	1	1	
13	7CT-E1971-00	SHAFT, FLYWEIGHT	1	1	1	
14	90338-06800	PLUG		1	1	FOR MX360A46A5
15	7HD-E5451-10	GASKET, CRANKCASE COVER 1	1	1	1	
16	95812-08045	BOLT, FLANGE	8	8	8	
17	7BX-E536A-20	PLUG, OIL LEVEL	1	1	1	
18	93210-22805	.O-RING	1	1	1	
19	7VB-E536A-00	PLUG, OIL LEVEL	1	1	1	
20	93210-22805	.O-RING	1	1	1	

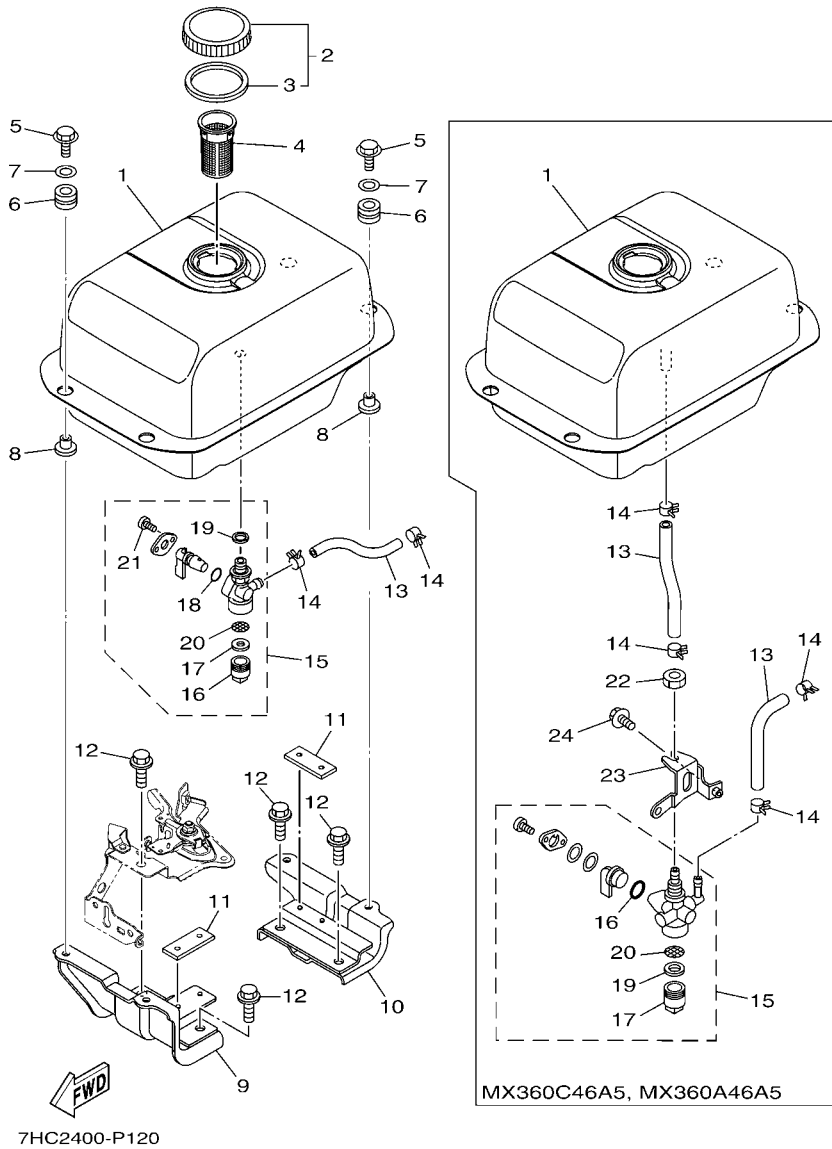

FIG. 12 FUEL TANK

REF. NO.	PART NO.	DESCRIPTION	7HC2	7HC3	7HCJ	REMARKS
1	7HC-F4110-10	FUEL TANK COMP.	1		1	FOR MX360AA6A0
	7HC-F4110-20	FUEL TANK COMP.		1	1	FOR MX360A46A5
2	7CN-F4610-01	CAP ASSY	1	1	1	
3	7CN-F4612-01	.PACKING, CAP	1	1	1	
4	7CN-F4167-00	STRAINER	1	1	1	
5	7CT-F4176-00	BOLT 1	4	4	4	
6	90480-15235	GROMMET	4	4	4	
7	90201-06085	WASHER, PLATE	4	4	4	
8	90387-068K8	COLLAR	4	4	4	
9	7HC-F4115-00	STAY, FUEL TANK 1	1	1	1	Go to P/N : PE0-MP-170004
10	7HC-F4116-00	STAY, FUEL TANK 2	1	1	1	Go to P/N : PE0-MP-170004
11	7VB-F4181-00	DAMPER, LOCATING 1	2	2	2	
12	95812-08020	BOLT, FLANGE	4	4	4	
13	90445-10456	HOSE (L95)	1		1	FOR MX360AA6A0
	90445-100E9	HOSE (L155)		2	2	FOR MX360A46A5
14	90467-09806	CLIP	2		2	FOR MX360AA6A0
	90467-09806	CLIP		4	4	FOR MX360A46A5
15	7CN-F4500-00	FUEL COCK ASSY 1	1		1	FOR MX360AA6A0
	7CN-F4500-11	FUEL COCK ASSY 1		1	1	FOR MX360A46A5
16	7J3-24521-00	.CUP, FILTER	1		1	FOR MX360AA6A0
	7CN-F4534-00	.SEAL, COCK		1	1	FOR MX360A46A5
17	4X8-24565-00	.GASKET	1		1	FOR MX360AA6A0
	7J3-24521-00	.CUP, FILTER		1	1	FOR MX360A46A5
18	7NJ-24534-00	.SEAL, COCK	1		1	FOR MX360AA6A0
	4X8-24565-00	.GASKET		1	1	FOR MX360A46A5
	7NJ-24532-00	.GASKET	1		1	FOR MX360AA6A0
20	7CN-F4515-10	.NET, FILTER 2		1	1	FOR MX360A46A5

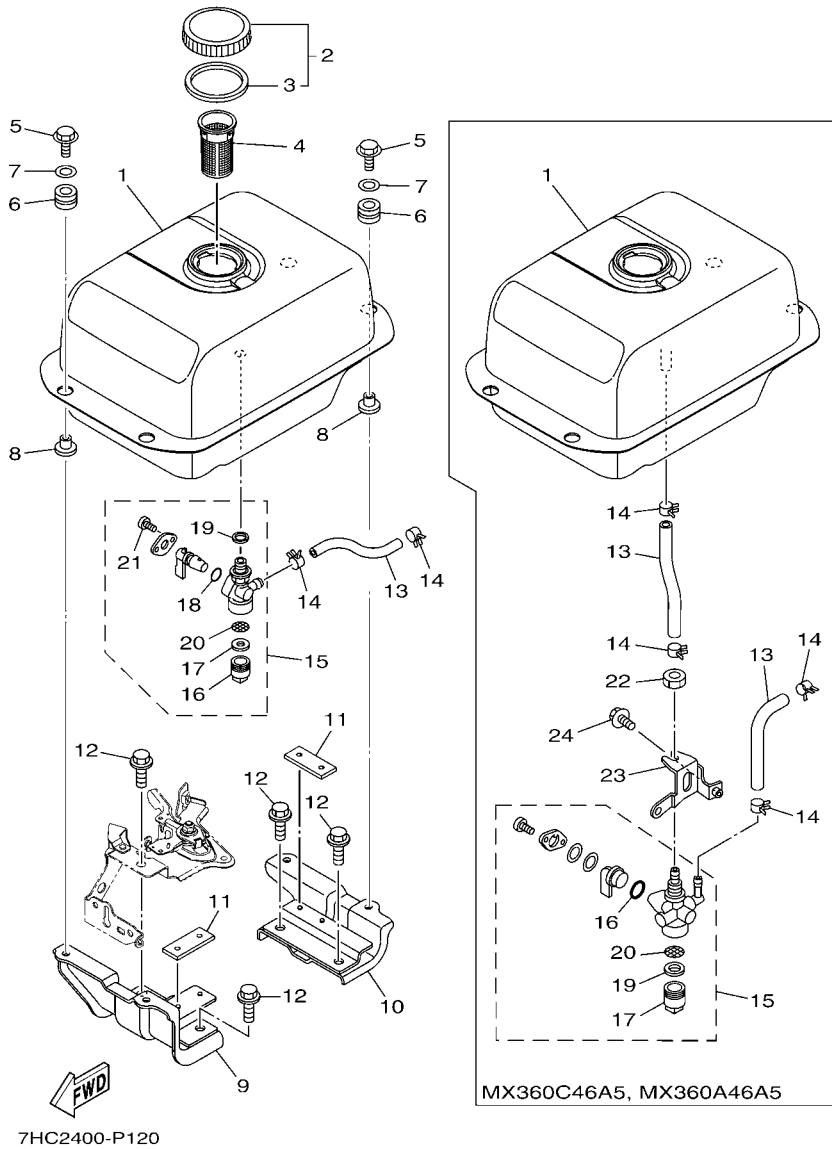

FIG. 12 FUEL TANK

REF. NO.	PART NO.	DESCRIPTION	7HC2	7HC3	7HCJ	REMARKS
20	7NJ-24515-01	.NET, FILTER 2	1		1	FOR MX360AA6A0
21	98507-03008	.SCREW, PAN HEAD	2		2	FOR MX360AA6A0
22	95302-10700	NUT, HEXAGON		1	1	FOR MX360A46A5
23	7HC-F4544-00	BRACKET, FUEL COCK		1	1	FOR MX360A46A5
24	95802-06016	BOLT, FLANGE		1	1	FOR MX360A46A5

PARTS NEWS

News No. PE0-MP-170004

Date: Dec., 19., 2017

Signature: K. Tanaka

Cause : Revision Notice Correction Sales Unit Change Others

Model	MX360 (See the "Applicable Engine Serial No. below.")
Subject	PARTS CATALOGUE CORRECTIONS
CATALOGUE NO.	1P7HC-400E1
Time of YPEC Revision	Text, Illustration --> Jan./10/2018
	PDF Replace --> Jan./10/2018
(YPEC = Yamaha Parts Electrical Catalogue = Website parts catalogue)	

Applicable Engine Serial No.

MODEL NAME	MODEL CODE	Applicable Engine Serial No.
MX360BA6A0	7HC2	1000842 and following
MX360C46A5	7HC3	1000221 and following
MX360AA6A0	7HCJ	1000188 and following
MX360A46A5	7HCJ	2000165 and following

*1: Interchangeability

A	Old Parts	→	Old Parts
	New Parts	→	New Parts
B	Old Parts	→	Old Parts
	New Parts	→	New Parts
C	Old Parts	→	Old Parts
	New Parts	→	New Parts
	○ These parts are interchangeable with a set		

FIG.12 FUEL TANK

1. LIST CORRECTION

Fig. No.	Ref. No.	OLD P/No.	NEW P/No.	DESCRIPTION	Q'TY	*Interchangeability	
						REMARKS	
12	9	7HC-F4115-00	7HC-F4115-10	STAY, FUEL TANK 1	1	○	*Part revision
	25	-	7HC-F4117-00	STAY, FUEL TANK 3	1	○	*Added Parts
	10	7HC-F4116-00	7HC-F4116-10	STAY, FUEL TANK 2	1	○	*Part revision
	26	-	7HC-F4118-00	STAY, FUEL TANK 4	1	○	*Added Parts

2. ILLUSTRATION CORRECTION

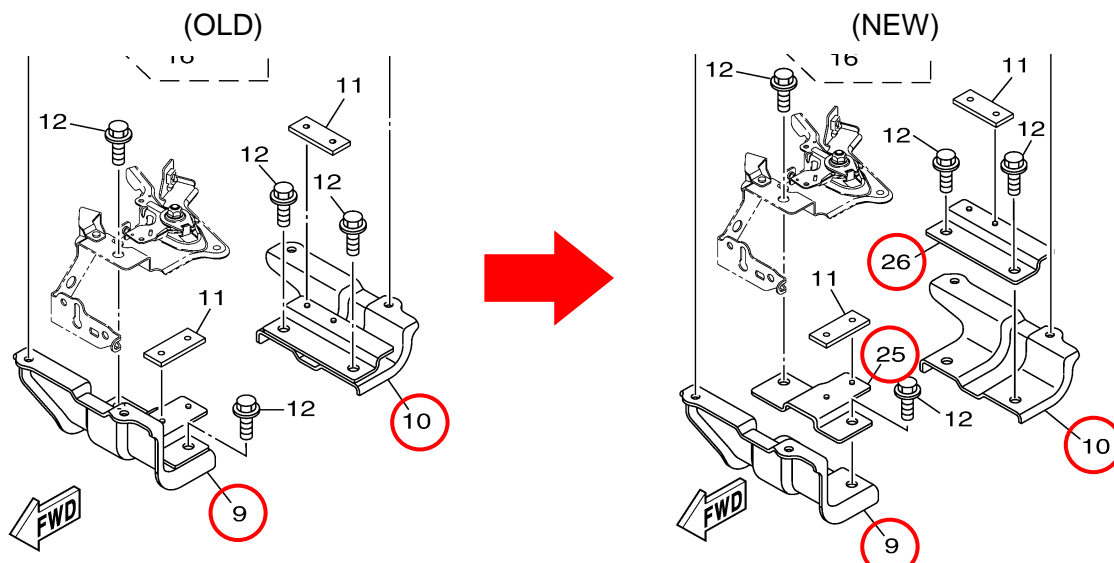

Thank you very much for your cooperation.

Parts Manager Check

Service Manager Check

Parts Manager File

YAMAHA MOTOR CO.,LTD
 Spare Parts Section
 Parts & ACC. Engineering Div., YMC.

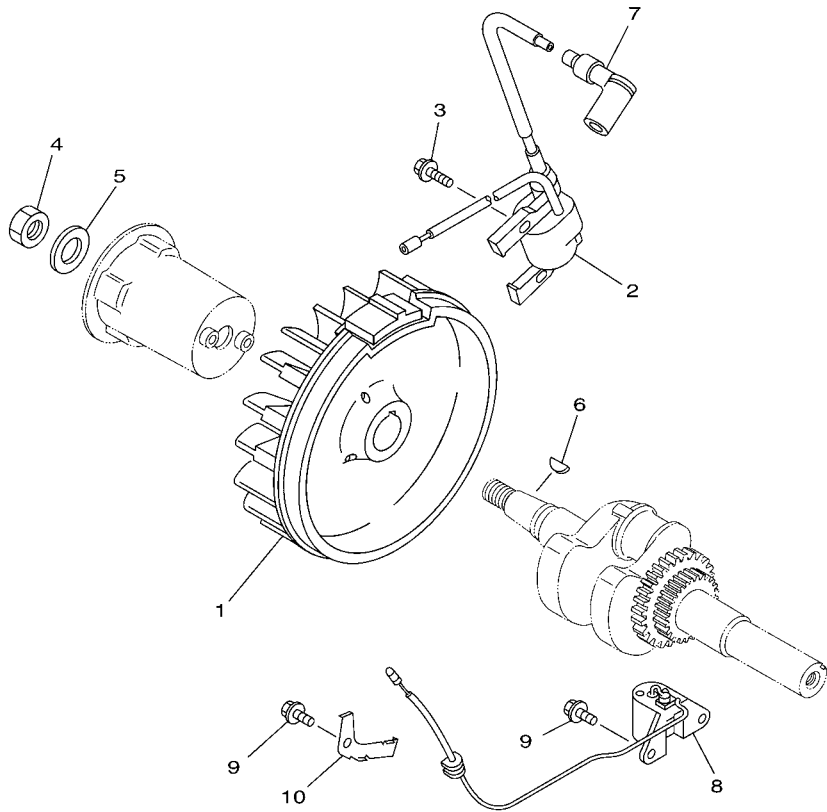

 7CT1400-D190

FIG. 13 TCI MAGNETO

REF. NO.	PART NO.	DESCRIPTION	7HC2	7HC3	7HCJ	REMARKS
1	7CT-H5650-00	ROTOR ASSY	1	1	1	
2	7CT-H5640-01	T.C.I. UNIT ASSY	1	1	1	
3	95880-06020	BOLT, FLANGE	2	2	2	
4	90170-18391	NUT	1	1	1	
5	90201-18802	WASHER, PLATE	1	1	1	
6	90280-04801	KEY, WOODRUFF	1	1	1	
7	7CN-H2370-00	PLUG CAP ASSY	1	1		FOR MX360AA6A0
	7CN-H2370-10	PLUG CAP ASSY		1	1	FOR MX360A46A5
8	7HD-H5720-00	OIL LEVEL GAUGE ASSY	1	1		FOR MX360AA6A0
9	95822-06012	BOLT, FLANGE	3	3		FOR MX360AA6A0
10	7CN-H5724-10	CLAMP	1	1		FOR MX360AA6A0

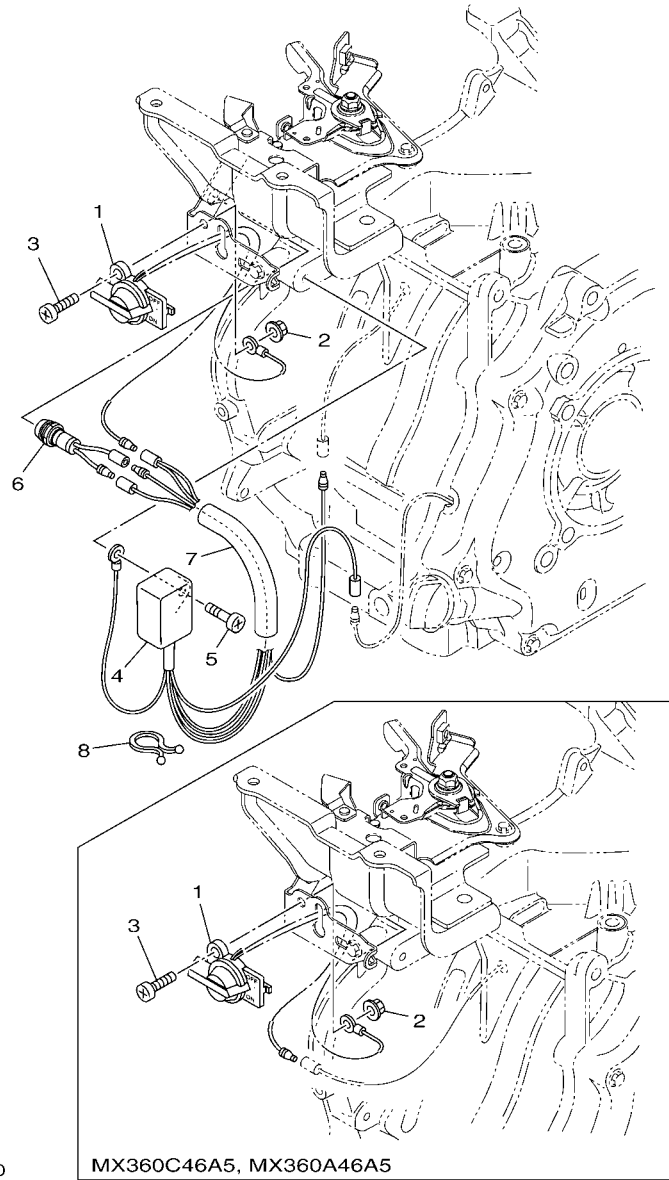

7HC2400-P140

FIG. 14 ELECTRICAL

REF. NO.	PART NO.	DESCRIPTION	7HC2	7HC3	7HCJ	REMARKS
1	7HC-H2550-00	ENGINE STOP SWITCH ASSY	1	1	1	
2	95704-06500	NUT, FLANGE	1	1	1	
3	98502-06014	SCREW, PAN HEAD	1	1	1	
4	7CN-H5690-00	OIL WARNING UNIT	1		1	FOR MX360AA6A0
5	98580-06020	SCREW, PAN HEAD	1		1	FOR MX360AA6A0
6	7CA-H5770-01	OIL PILOT LIGHT ASSY	1		1	FOR MX360AA6A0
7	7CU-H2589-00	PROTECTOR, WIRE HARNESS	1		1	FOR MX360AA6A0
8	90464-11806	CLAMP	1		1	FOR MX360AA6A0

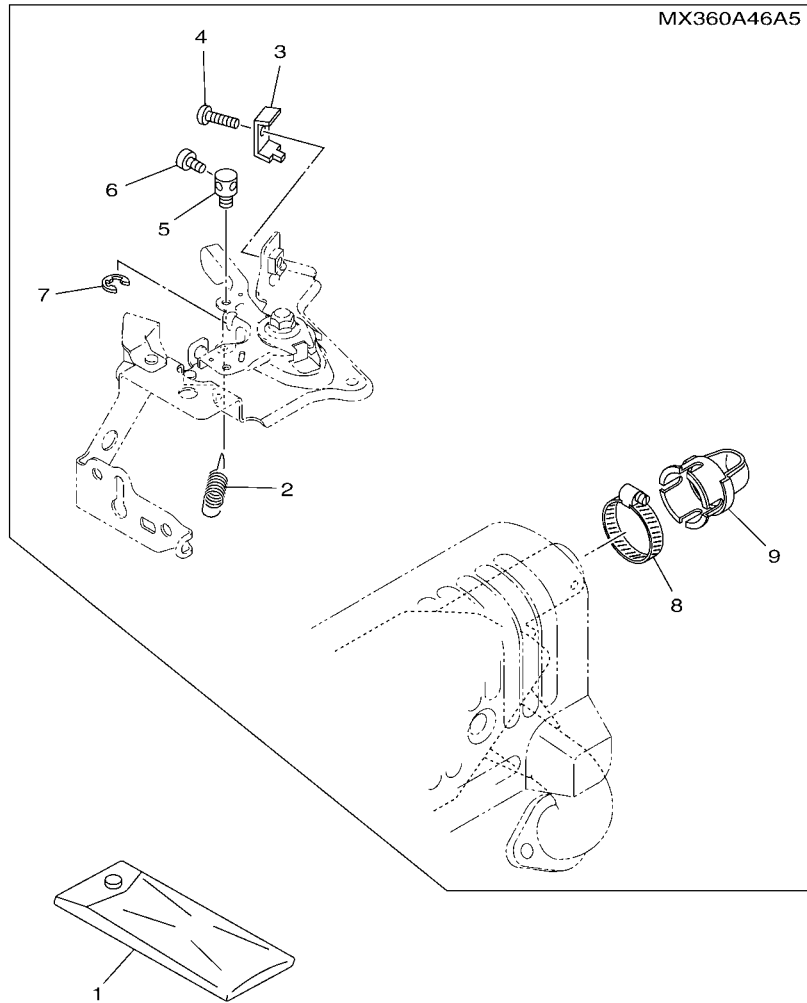

7HC2400-P150

FIG. 15 BODY FITTING

REF. NO.	PART NO.	DESCRIPTION	7HC2	7HC3	7HCJ	REMARKS
1	7CT-F8100-00	TOOL KIT	1	1	1	
2	90506-07412	SPRING, TENSION			1	FOR MX360A46A5
3	7HC-E1933-00	PLATE, ADJUST			1	FOR MX360A46A5
4	98502-05016	SCREW, PAN HEAD			1	FOR MX360A46A5
5	7CT-E1932-00	SETTER, WIRE			1	FOR MX360A46A5
6	98502-04006	SCREW, PAN HEAD			1	FOR MX360A46A5
7	99001-04600	CIRCLIP			1	FOR MX360A46A5
8	90450-38804	HOSE CLAMP ASSY			1	FOR MX360A46A5
9	7CT-E4746-00	PIPE, MUFFLER TAIL			1	FOR MX360A46A5

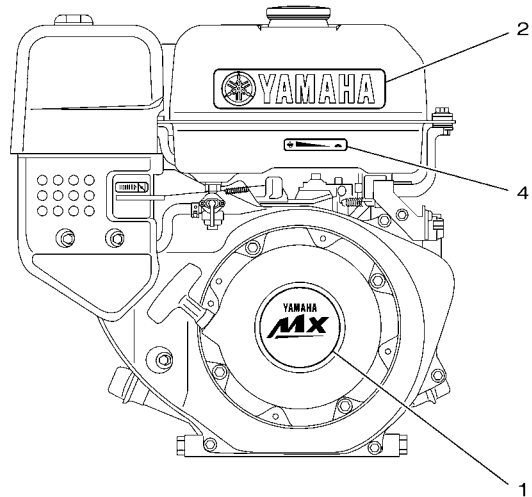
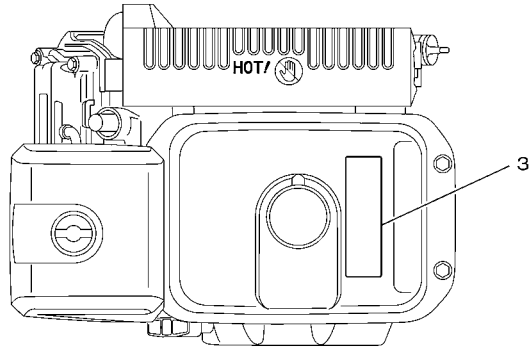

7HC2400-P160

FIG. 16 EMBLEM & LABEL

REF. NO.	PART NO.	DESCRIPTION	7HC2	7HC3	7HCJ	REMARKS
1	7HC-E2629-00	EMBLEM (YAMAHA MX360)	1	1	1	
2	7PB-F4161-30	EMBLEM 1 (YAMAHA)		1	1	
3	7CN-F4162-20	EMBLEM 2 (WARNING)	1	1	1	
4	7HC-F4154-00	INDICATOR, SHIFT	1	1	1	

NUMERICAL INDEX

PART NO.	REF. NO.	PART NO.	REF. NO.	PART NO.	REF. NO.	PART NO.	REF. NO.	PART NO.	REF. NO.	PART NO.	REF. NO.
7NJ-24515-01	12 - 20	7CT-E2118-00	6 - 7	7HC-E4A43-58	9 - 19	7HD-H5720-00	13 - 8	93306-252YK	11 - 5		
7J3-24521-00	12 - 16	7CT-E2119-00	6 - 14	7HC-E4A81-00	9 - 17	7CN-H5724-10	13 - 10		11 - 12		
	12 - 17	7HD-E2121-00	6 - 3	7HC-E5111-00	11 - 1	7CA-H5770-01	14 - 6	93306-307Y3	11 - 2		
7NJ-24532-00	12 - 19	7CT-E2151-00	6 - 8	7VB-E536A-00	11 - 19	90113-05800	6 - 12	93440-06826	4 - 5		
7NJ-24534-00	12 - 18	7CT-E2153-00	6 - 4	7BX-E536A-20	11 - 17	90170-05806	6 - 10		5 - 5		
4X8-24565-00	12 - 17	7HD-E2154-00	6 - 13	7HC-E5411-00	11 - 9	90170-18391	13 - 4	93450-22840	3 - 4		
	12 - 19	7HD-E2156-00	6 - 11	7HC-E5411-10	11 - 9	90173-06802	4 - 13	94702-00819	1 - 6		
7HD-E1111-10	1 - 1	7CT-E2159-00	6 - 9	7HD-E5451-10	11 - 15		5 - 13	95302-08600	10 - 8		
7CT-E1166-00	1 - 10	7HD-E2170-00	6 - 1	7HC-E5710-00	7 - 7	90175-06809	8 - 9	95302-10700	12 - 22		
7HD-E1181-00	1 - 2	7HD-E261H-00	7 - 6	7HC-E5713-00	7 - 10	90201-06085	12 - 7	95602-08710	1 - 11		
7HD-E1190-10	1 - 7	7HD-E2621-00	7 - 1	7HC-E5714-00	7 - 8	90201-067L0	4 - 6	95622-08618	1 - 5		
7HD-E1193-00	1 - 8	7HC-E2629-00	16 - 1	7HC-E5715-00	7 - 11		5 - 6	95702-08500	8 - 13		
7CT-E1198-00	11 - 7	7HC-E2651-00	7 - 3	7HC-E5716-00	7 - 14	90201-06842	4 - 4	95704-06500	14 - 2		
7HD-E1400-10	2 - 1	7HC-E2652-00	7 - 4	7HC-E5719-00	7 - 12		5 - 4	95802-06012	4 - 20		
7HD-E1400-20	2 - 1	7CT-E3557-00	8 - 2	7HC-E5723-00	7 - 19	90201-08856	10 - 7		5 - 20		
7HD-E1400-50	2 - 1	7HC-E3567-00	8 - 3	7HC-E5741-00	7 - 9	90201-08858	4 - 9		7 - 2		
7CT-E1454-00	3 - 7	7CT-E3596-00	8 - 1	7HC-E5743-00	7 - 13		5 - 9		7 - 2		
7CT-E1561-00	3 - 8	7HC-E4117-00	9 - 7	7CT-E5751-00	7 - 16	90201-18802	13 - 5		7 - 5		
7HD-E1610-00	3 - 2	7HC-E4150-00	9 - 13	7CN-E5755-00	7 - 17	90280-04801	13 - 6	95802-06016	7 - 18		
7HD-E1610-10	3 - 2	7HC-E4159-00	9 - 11	7HC-E5793-00	7 - 15	90282-06037	2 - 2		8 - 14		
7HD-E1610-20	3 - 2	7HC-E4162-00	9 - 10	7HC-F4110-10	12 - 1	90282-07061	2 - 2		12 - 24		
7HD-E1631-00-A0	3 - 1	7HC-E4184-00	9 - 15	7HC-F4110-20	12 - 1	90338-06800	11 - 14	95812-08020	12 - 12		
7HD-E1633-00	3 - 3	7HC-E4185-00	9 - 16	7HC-F4115-00	12 - 9	90340-12097	11 - 6	95812-08045	11 - 16		
7HD-E1635-00	3 - 1	7BX-E4186-00	9 - 12	7HC-F4116-00	12 - 10	90387-068K8	12 - 8	95812-10070	1 - 3		
7HD-E1636-00	3 - 1	7HC-E4191-00	9 - 21	7HC-F4154-00	16 - 4	90445-100E9	12 - 13	95822-06008	10 - 5		
7HD-E1650-01	3 - 5	7BX-E4212-00	9 - 4	7CN-F4155-00	8 - 11	90445-10456	12 - 13	95822-06012	13 - 9		
7CT-E1654-00	3 - 6		9 - 20	7PB-F4161-30	16 - 2	90450-38804	15 - 8	95822-06030	1 - 9		
7CT-E1913-00	4 - 2	7BX-E4216-00	9 - 3	7CN-F4162-20	16 - 3	90464-11806	14 - 8	95822-08016	10 - 6		
	5 - 2	7HC-E4227-00	9 - 9	7CN-F4167-00	12 - 4	90467-09806	12 - 14	95880-06020	13 - 3		
7CT-E1914-00	4 - 3	7HC-E4239-00	9 - 8	7CT-F4176-00	12 - 5		12 - 14	97522-06530	4 - 12		
	5 - 3	7HC-E4301-20	9 - 1	7VB-F4181-00	12 - 11	90468-12801	4 - 10		5 - 12		
7CT-E1917-00	4 - 7	7HC-E4411-00	8 - 4	7CN-F4500-00	12 - 15		5 - 10	97702-40506	10 - 3		
	5 - 7	7HC-E4412-00	8 - 5	7CN-F4500-11	12 - 15	90480-15235	12 - 6	98502-04006	4 - 24		
7CT-E1922-00	4 - 8	7HC-E4430-00	8 - 6	7CN-F4515-10	12 - 20	90501-090A8	4 - 18		15 - 6		
	5 - 8	7HC-E4439-00	8 - 10	7CN-F4534-00	12 - 16		5 - 18	98502-05016	4 - 22		
7HC-E1924-10	4 - 11	7HC-E4450-00	8 - 7	7HC-F4544-00	12 - 23	90501-264A9	6 - 5		15 - 4		
	5 - 11	7HC-E4457-00	8 - 8	7CN-F4610-01	12 - 2	90506-04006	4 - 15	98502-05025	4 - 17		
7HC-E1928-00	4 - 14	7BX-E4486-00	9 - 2	7CT-F4612-01	12 - 3		5 - 15		5 - 17		
	5 - 14	7HC-E4499-00	8 - 12	7CT-F8100-00	15 - 1	90506-07412	4 - 26	98502-06014	14 - 3		
7CT-E1932-00	4 - 23	7HC-E4583-00	9 - 6	7HC-G1240-00	4 - 16		15 - 2	98507-03008	12 - 21		
	15 - 5	7HC-E4613-00	10 - 9		5 - 16	90506-14804	4 - 19	98580-06020	14 - 5		
7HC-E1933-00	4 - 21	7HC-E4708-00	10 - 4	7CN-H2370-00	13 - 7		5 - 19	99001-04600	4 - 25		
	15 - 3	7HC-E4721-00	10 - 1	7CN-H2370-10	13 - 7	93102-35802	11 - 3		15 - 7		
7CT-E1970-10	4 - 1	7CT-E4746-00	15 - 9	7HC-H2550-00	14 - 1		11 - 11	99530-08016	11 - 8		
	5 - 1	7BY-E4786-00	10 - 2	7CU-H2589-00	14 - 7	93109-08803	11 - 4	99530-14016	1 - 4		
7CT-E1971-00	11 - 13	7HC-E4922-00	9 - 5	7CT-H5640-01	13 - 2	93210-22805	11 - 18				
7CT-E2111-00	6 - 2	7HC-E4A41-00	9 - 18	7CT-H5650-00	13 - 1		11 - 20				
7CT-E2117-00	6 - 6	7HC-E4A42-24	9 - 14	7CN-H5690-00	14 - 4	93306-207Y2	11 - 10				