

PARTS CATALOGUE

MX400A3E (7HSJ) CSA, EUR, SEA



1S7HS-300E1

()

2019/9/20

NEWS NO.	DATE	COMMENT
PE0-MP-190007	Sep.,19,2019	MOD:FIG.8 CARBURETOR LIST REVISION

MX400A3E
PARTS CATALOGUE
©2017 by Yamaha Motor Co., Ltd.
1st edition, November 2017
All rights reserved.
Any reprinting or unauthorized use
without the written permission of
Yamaha Motor Co., Ltd.
is expressly prohibited.
Printed in Japan.

FOREWORD

This Parts Catalogue is related to the parts for the model(s) on the cover page. When you are ordering replacement parts, please refer to this Parts Catalogue and quote both part numbers and part names correctly.

1. Modifications or additions which have been made after the issue of the Parts Catalogue will be announced in the Parts News.
It is advisable that you make the necessary corrections to the Parts Catalogue according to the Parts News.
2. Abbreviations
The following abbreviations are used in this Parts Catalogue.
“UR” Use specified parts number.
“UN” Use as many as needed.
“AP” Alternate Parts
“LM” Locally Made (Parts need to be ordered locally)
“F#” Frame No. (Applicable machine No.)
“O/S” Over Size
3. The number of components for assembly
 - Parts, which are to be supplied in an assembly, are listed with a dot (.) in front of the part name as shown below.
 - The numeral appearing to the right of each component part indicates the quantity of parts for each assembly unit.

PART NO.	DESCRIPTION	Q'TY	REMARKS
2F5-83310-60	FRONT FLASHER LIGHT ASSY	2	
115-83311-60	.BULB (6V-18W)	1	

4. Applicable colours of graphics are represented in the “REMARKS” as shown below.

PART NO.	DESCRIPTION	Q'TY	REMARKS
2N4-24110-00-X5	FUEL TANK COMP.	2	MXR
3J1-24240-10	.GRAPHIC, FUEL TANK	1	FOR MXR

5. Note that the illustrations for reference in finding parts numbers are not to be used for assembling. When assembling, please use the applicable service manual.

6. The asterisk (*) before a reference number indicates modified items after the first edition.

FOREWORD

Engine Serial No.

This parts catalogue is related to the parts for the models in the list below.

MODEL CODE	MODEL NAME	SPECIFICATION (OUT LINE)	ENGINE SERIAL NO.
7HSJ	MX400A3E	P.T.O. SHAFT A TYPE, MOUNT FACE (UNF)	7HSJ-2000101

CONTENTS

CYLINDER.....	1
CRANKSHAFT.....	2
CRANKSHAFT & PISTON.....	3
GOVERNOR.....	4
CAMSHAFT & VALVE.....	5
AIR SHROUD & STARTER.....	6
INTAKE.....	7
CARBURETOR.....	8
EXHAUST.....	9
CRANKCASE.....	10
FUEL TANK.....	11
TCI MAGNETO.....	12
STARTING MOTOR.....	13
ELECTRICAL.....	14
BODY FITTING.....	15
EMBLEM & LABEL.....	16

INDEX

NUMERICAL INDEX.....	17
----------------------	----

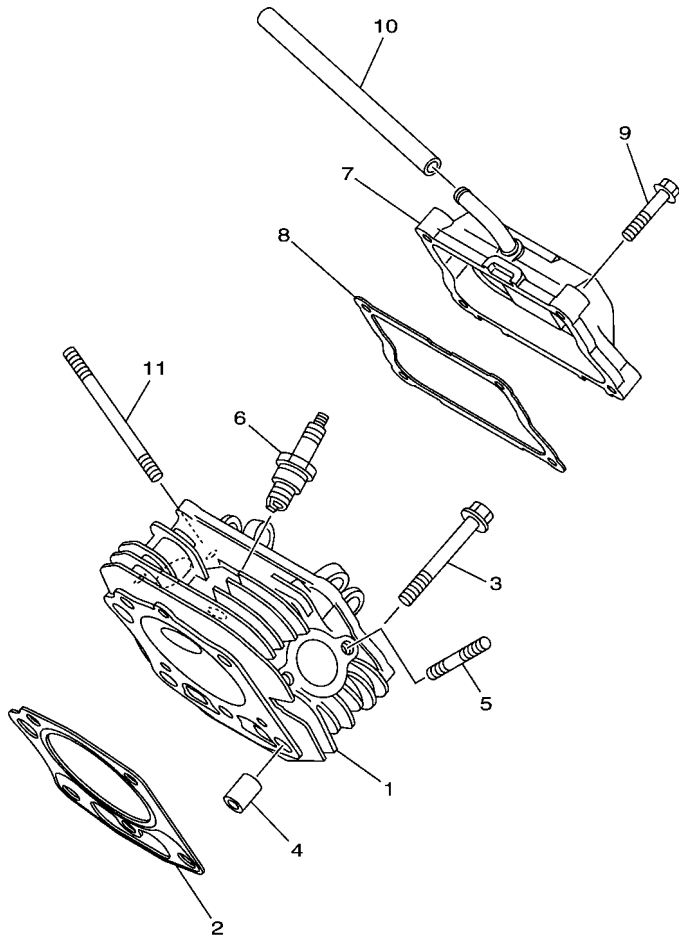

7P62110-N010

FIG. 1 CYLINDER

REF. NO.	PART NO.	DESCRIPTION	7HSJ				REMARKS
1	7HD-E1111-10	HEAD, CYLINDER 1	1				
2	7HD-E1181-00	GASKET, CYLINDER HEAD 1	1				
3	95812-10070	BOLT, FLANGE	5				
4	99530-14016	PIN, DOWEL	2				
5	95622-08618	BOLT, STUD	2				
6	94702-00819	PLUG, SPARK (NGK BPR4ES)	1				
7	7HD-E1190-10	COVER, CYLINDER HEAD 1	1				
8	7HD-E1193-00	GASKET, HEAD COVER 1	1				
9	95822-06030	BOLT, FLANGE	4				
10	7CT-E1166-00	PIPE, BREATHER 1	1				
11	95602-08710	BOLT, STUD	2				

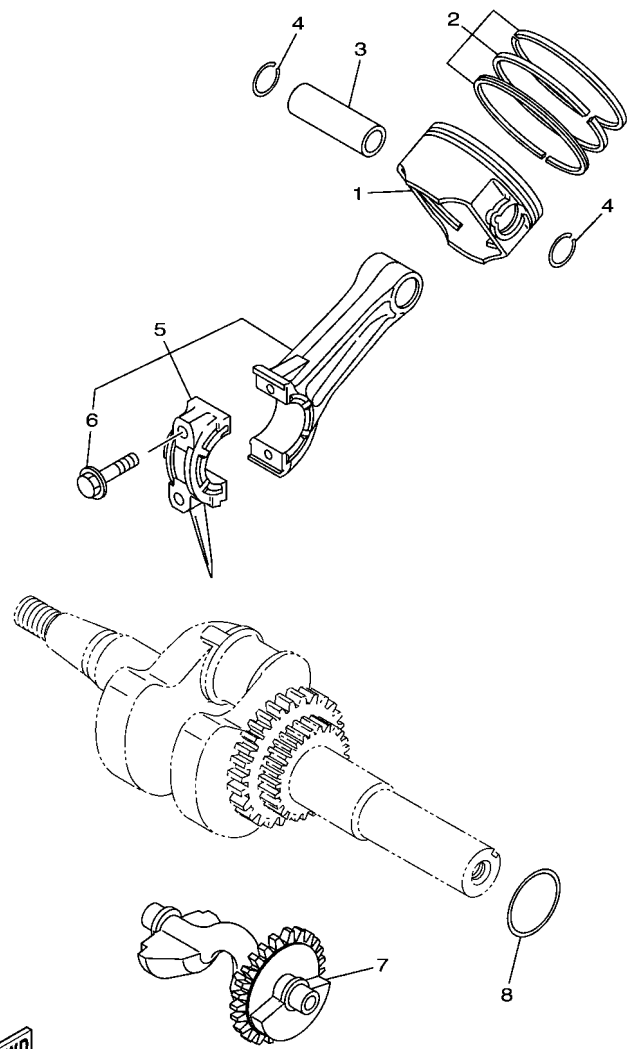

7HSJ110-R030

FIG. 3 CRANKSHAFT & PISTON

REF. NO.	PART NO.	DESCRIPTION	7HSJ				REMARKS
1	7HD-E1631-10-A0	PISTON (STD)	1				
	7HD-E1635-10	PISTON (0.25MM O/S)	1				AP
	7HD-E1636-10	PISTON (0.50MM O/S)	1				AP
2	7HD-E1610-00	PISTON RING SET (STD)	1				
	7HD-E1610-10	PISTON RING SET (0.25MM O/S)	1				AP
	7HD-E1610-20	PISTON RING SET (0.50MM O/S)	1				AP
3	7HD-E1633-00	PIN, PISTON	1				
4	93450-22840	CIRCLIP	2				
5	7HP-E1650-00	CONNECTING ROD ASSY	1				
6	7CT-E1654-00	.BOLT, CONNECTING ROD	2				
7	7HP-E1454-00	WEIGHT 1	1				
8	7CT-E1561-00	SHIM, CRANK 1	1				

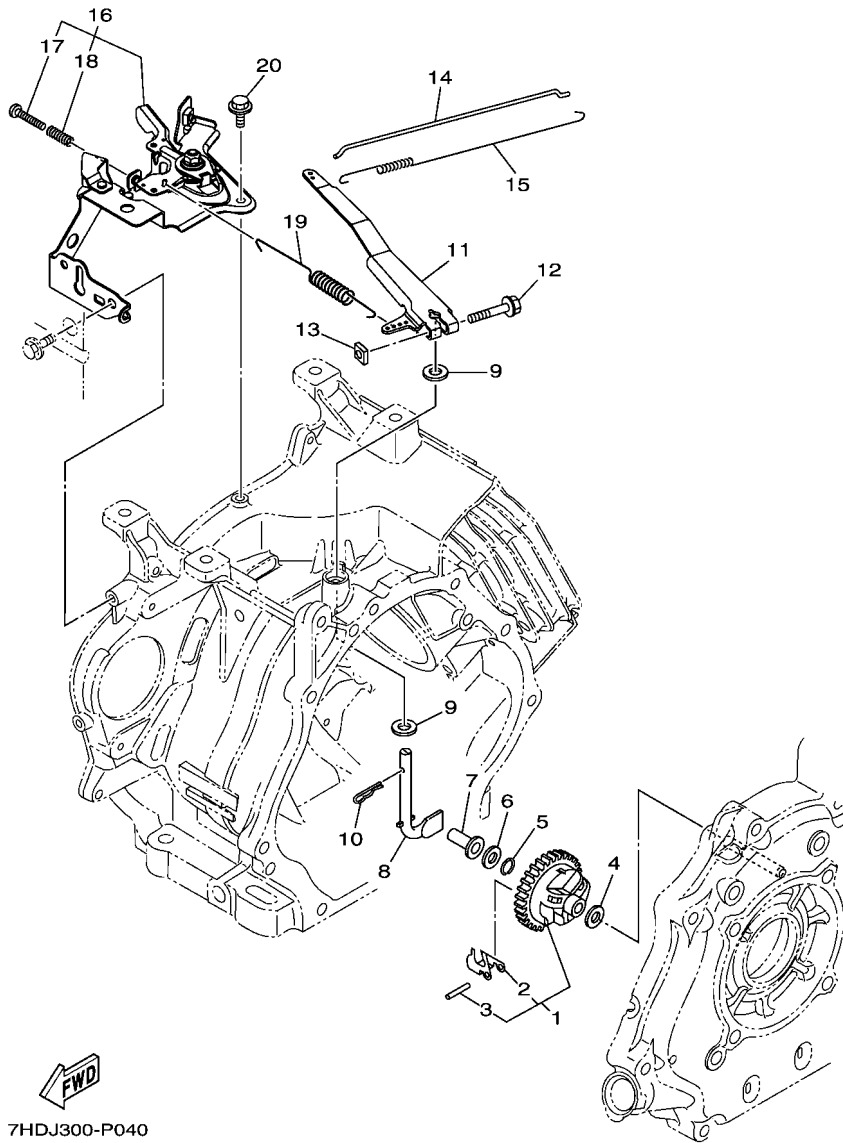
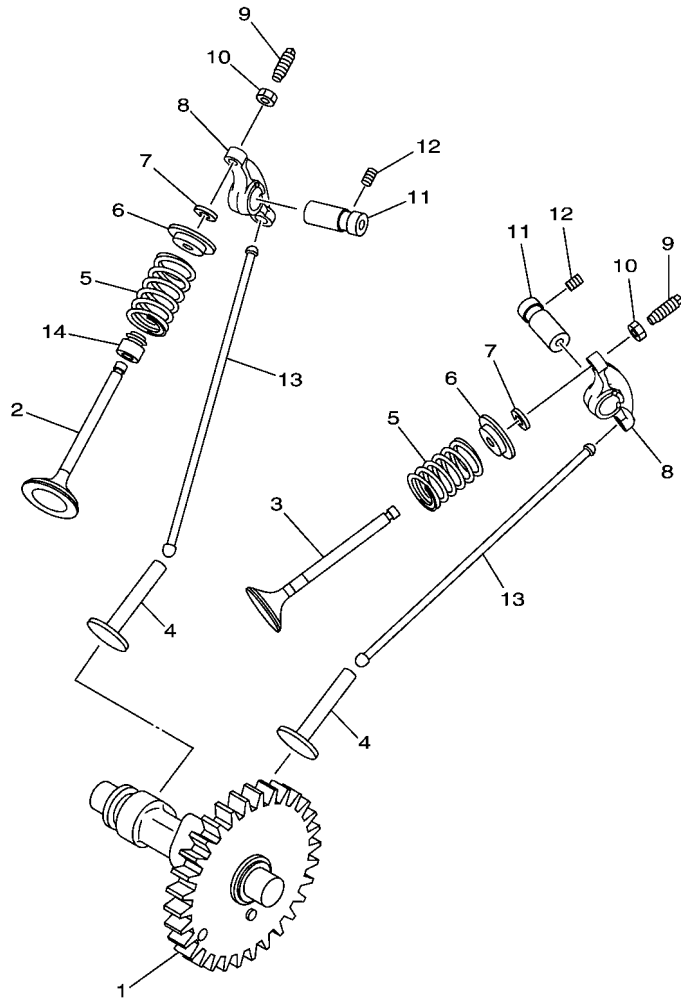

FIG. 4 GOVERNOR

REF. NO.	PART NO.	DESCRIPTION	7HSJ				REMARKS
1	7CT-E1970-10	FLYWEIGHT SHAFT ASSY	1				
2	7CT-E1913-00	.WEIGHT	3				
3	7CT-E1914-00	.SHAFT, WEIGHT	3				
4	90201-06842	WASHER, PLATE	1				
5	93440-06826	CIRCLIP	1				
6	90201-067L0	WASHER, PLATE	1				
7	7CT-E1917-00	COLLAR	1				
8	7CT-E1922-00	FORK, GOVERNOR	1				
9	90201-08858	WASHER, PLATE	2				
10	90468-12801	CLIP	1				
11	7HC-E1924-10	ARM, GOVERNOR	1				
12	97522-06530	BOLT, WITH WASHER	1				
13	90173-06802	NUT, SQUARE	1				
14	7HC-E1928-00	ROD, LINK	1				
15	90506-04006	SPRING, TENSION	1				
16	7HC-G1240-00	THROTTLE LEVER COMP.	1				
17	98502-05030	.SCREW, PAN HEAD	1				
18	90501-090A8	.SPRING, COMPRESSION	1				
19	90506-14804	SPRING, TENSION	1				
20	95802-06012	BOLT, FLANGE	1				

FIG. 5 CAMSHAFT & VALVE





7P62110-N040

REF. NO.	PART NO.	DESCRIPTION	7HSJ				REMARKS
1	7HD-E2170-00	CAMSHAFT ASSY 1	1				
2	7CT-E2111-00	VALVE, INTAKE	1				
3	7HD-E2121-00	VALVE, EXHAUST	1				
4	7CT-E2153-00	LIFTER, VALVE	2				
5	90501-264A9	SPRING, COMPRESSION	2				
6	7CT-E2117-00	RETAINER, VALVE SPRING	2				
7	7CT-E2118-00	LOCK, VALVE SPRING RETAINER	2				
8	7CT-E2151-00	ARM, VALVE ROCKER	2				
9	7CT-E2159-00	SCREW, VALVE ADJUSTING	2				
10	90170-05806	NUT	2				
11	7HD-E2156-00	SHAFT, ROCKER 2	2				
12	90113-05800	BOLT, SET	2				
13	7HD-E2154-00	ROD, VALVE PUSH	2				
14	7CT-E2119-00	SEAL, VALVE STEM	1				

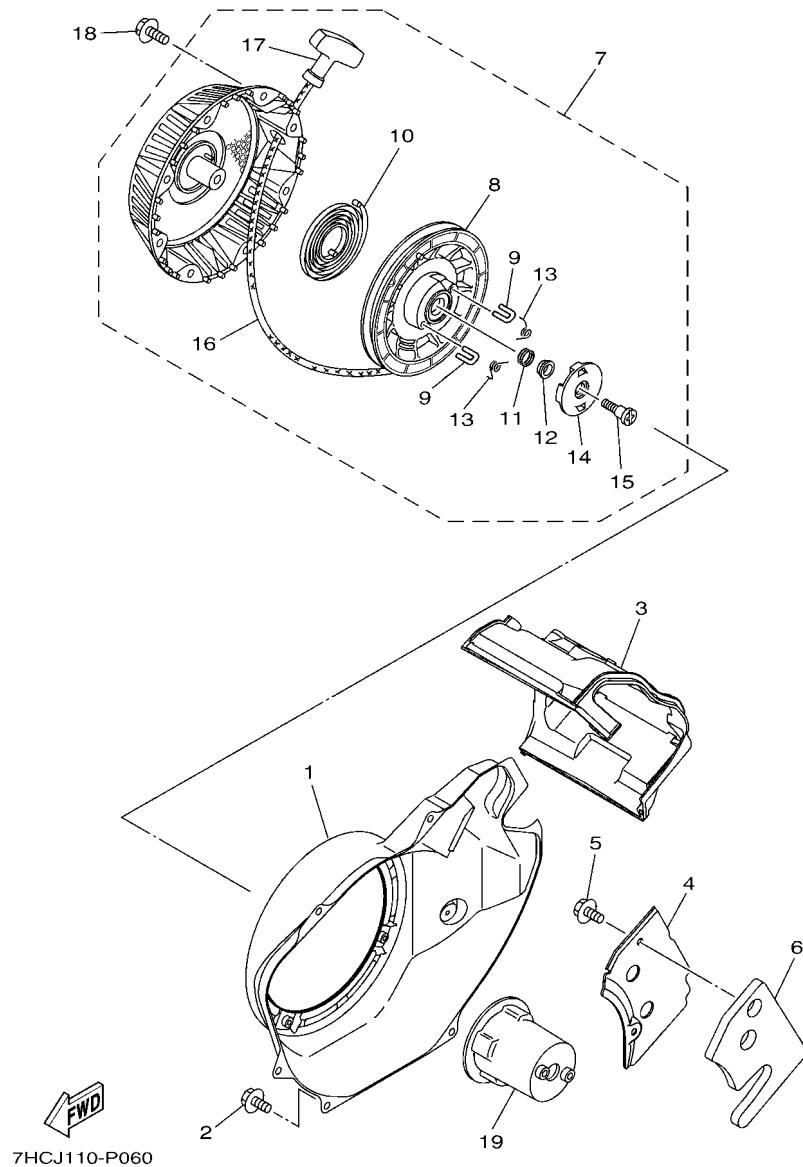
FIG. 6 AIR SHROUD & STARTER

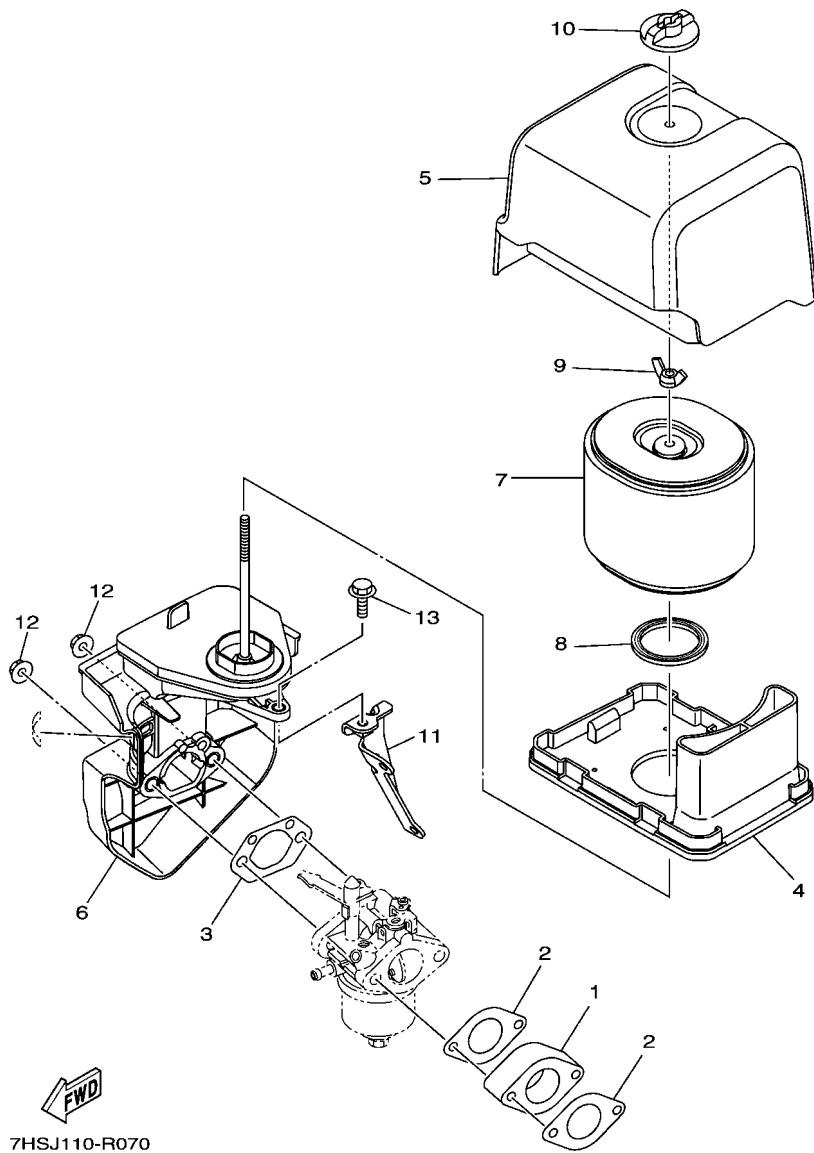

REF. NO.	PART NO.	DESCRIPTION	7HSJ				REMARKS
1	7HD-E2621-00	CASE, FAN	1				
2	95802-06012	BOLT, FLANGE	6				
3	7HC-E2651-00	AIR SHROUD, CYLINDER 1	1				
4	7HC-E2652-00	AIR SHROUD, CYLINDER 2	1				
5	95802-06012	BOLT, FLANGE	2				
6	7HC-E261H-00	SEAL 1	1				
7	7HC-E5710-00	STARTER ASSY	1				
8	7HC-E5714-00	.DRUM, SHEAVE	1				
9	7HC-E5741-00	.PAWL, DRIVE	2				
10	7HC-E5713-00	.SPRING, STARTER	1				
11	7HC-E5715-00	.SPRING, FRICTION	1				
12	7HC-E5719-00	.WASHER, THRUST	1				
13	7HC-E5743-00	.SPRING, RETURN	2				
14	7HC-E5716-00	.PLATE, DRIVE	1				
15	7HC-E5793-00	.SCREW	1				
16	7CT-E5751-00	.WIRE, STARTER	1				
17	7CN-E5755-00	.HANDLE, STARTER	1				
18	95802-06016	BOLT, FLANGE	4				
19	7HC-E5723-00	PULLEY, STARTER	1				



7HSJ110-R070

FIG. 7 INTAKE

REF. NO.	PART NO.	DESCRIPTION	7HSJ				REMARKS
1	7CT-E3596-00	JOINT, CARBURETOR 2	1				
2	7CT-E3557-00	GASKET	2				
3	7HC-E3567-00	GASKET	1				
4	7HC-E4411-00	CASE, AIR CLEANER 1	1				
5	7HC-E4412-00	CAP, CLEANER CASE 1	1				
6	7HC-E4430-01	DUCT ASSY	1				
7	7HC-E4450-00	ELEMENT ASSY, AIR CLEANER	1				
8	7HC-E4457-00	SEAL	1				
9	90175-06809	NUT, WING	1				
10	7HC-E4439-00	NUT	1				
11	7HP-E4499-00	STAY 2	1				
12	95702-08500	NUT, FLANGE	2				
13	95802-06016	BOLT, FLANGE	1				

FIG. 8 CARBURETOR

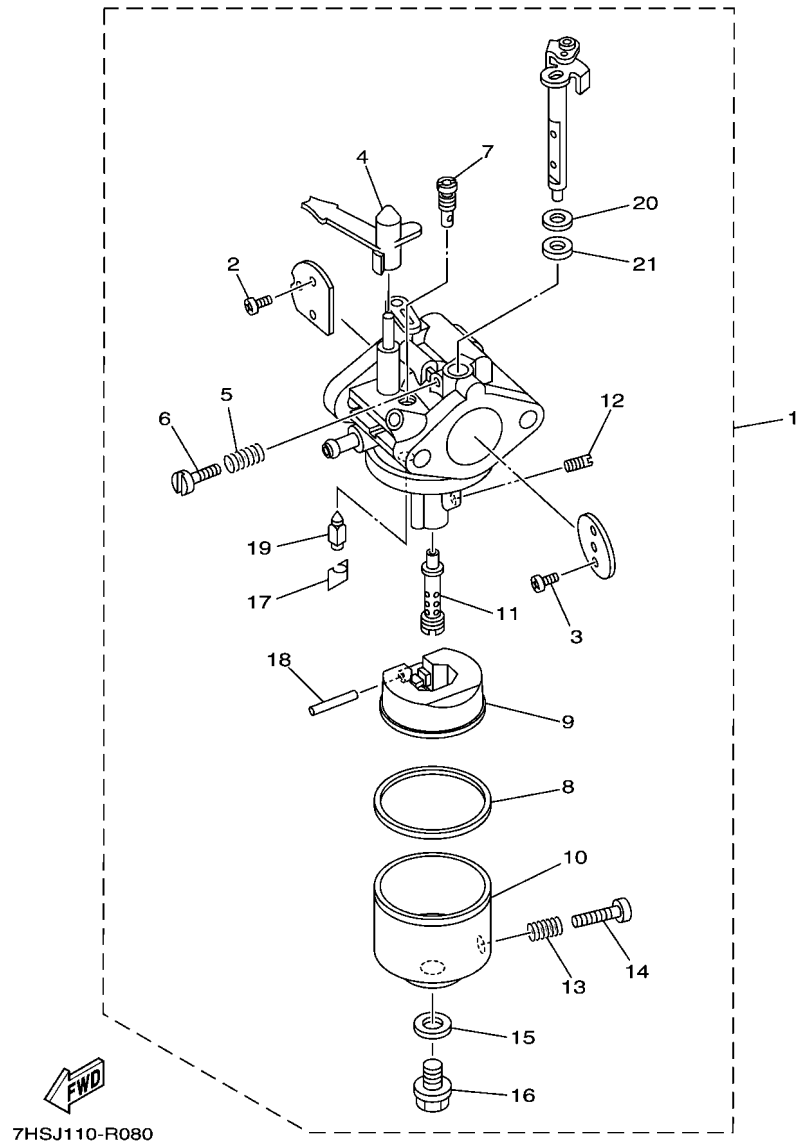

REF. NO.	PART NO.	DESCRIPTION	7HSJ				REMARKS
1	7HP-E4301-01	CARBURETOR ASSY 1	1				Go to P/N : PE0-MP-190007
2	7BX-E4486-00	.SCREW, ROD	2				
3	7BX-E4216-00	.SCREW	2				
4	7HC-E4583-00	.LEVER, CHOKE	1				
5	7BX-E4212-00	.SPRING, PILOT ADJUSTING	1				
6	7HC-E4922-00	.SCREW, THROTTLE	1				
7	7HC-E4A42-79	.JET, PILOT	1				
8	7HC-E4184-00	.GASKET, FLOAT CHAMBER	1				
9	7HC-E4185-00	.FLOAT	1				
10	7HC-E4A81-00	.BODY, FLOAT CHAMBER 1	1				
11	7HP-E4A41-00	.NOZZLE, MAIN	1				
12	7HC-E4A43-65	.JET, MAIN	1				
13	7BX-E4212-00	.SPRING, PILOT ADJUSTING	1				
14	7HC-E4191-00	.PLUG, DRAIN	1				
15	7HC-E4227-00	.WASHER	1				
16	7HC-E4162-00	.BOLT, HOLDING	1				
17	7HC-E4159-00	.CLIP	1				
18	7BX-E4186-00	.PIN, FLOAT	1				
19	7HC-E4150-00	.NEEDLE ASSY	1				
20	7HC-E4117-00	.WASHER, PLUG SCREW	1				
21	7HC-E4239-00	.SEAL	1				

PARTS NEWS

News No. PE0-MP-190007

Date: Sep., 19., 2019

Signature: K. Tanaka

Cause : Revision Notice Correction Sales Unit Change Others

Model	MX400 (See the "List of Models and CATALOGUE No's below.")
Subject	PARTS CATALOGUE CORRECTIONS
CATALOGUE NO.	See the "List of Models and CATALOGUE No's below."
Time of YPEC Revision	Text, Illustration --> Oct./20/2019 PDF Replace --> Oct./20/2019 (YPEC = Yamaha Parts Electrical Catalogue = Website parts catalogue)

LIST of Models and CATALOGUE No's.

The applicable MODELS, MODEL CODES, and CATALOGUE No's are as follows.

MODEL NAME	MODEL CODE	CATALOGUE NO.	Applicable Engine Serial No.
MX400AA6A0	7HP1	1R7HP-300E1	7HP1-1002220 and following
MX400KA6G0	7HPN	1R7HP-300EA	7HPN-1000294 and following
MX400KA6S0	7HSN	1R7HS-300E1	7HSN-1000247 and following
MX400A3E	7HSJ	1S7HS-300E1	7HSJ-2000104 and following

FIG.8 CARBURETOR

LIST CORRECTION

Ref. No.	OLD P/No.	NEW P/No.	DESCRIPTION	Q'TY	REMARKS
1	7HP-E4301-01	7HP-E4301-30	CARBURETOR ASSY 1	1	*Part revision

Thank you very much for your cooperation.

Parts
Manager
CheckService
Manager
CheckParts
Manager
FileYAMAHA MOTOR CO.,LTD
Spare Parts Section
Technical & New Model Info. Gr., YMC

FIG. 9 EXHAUST

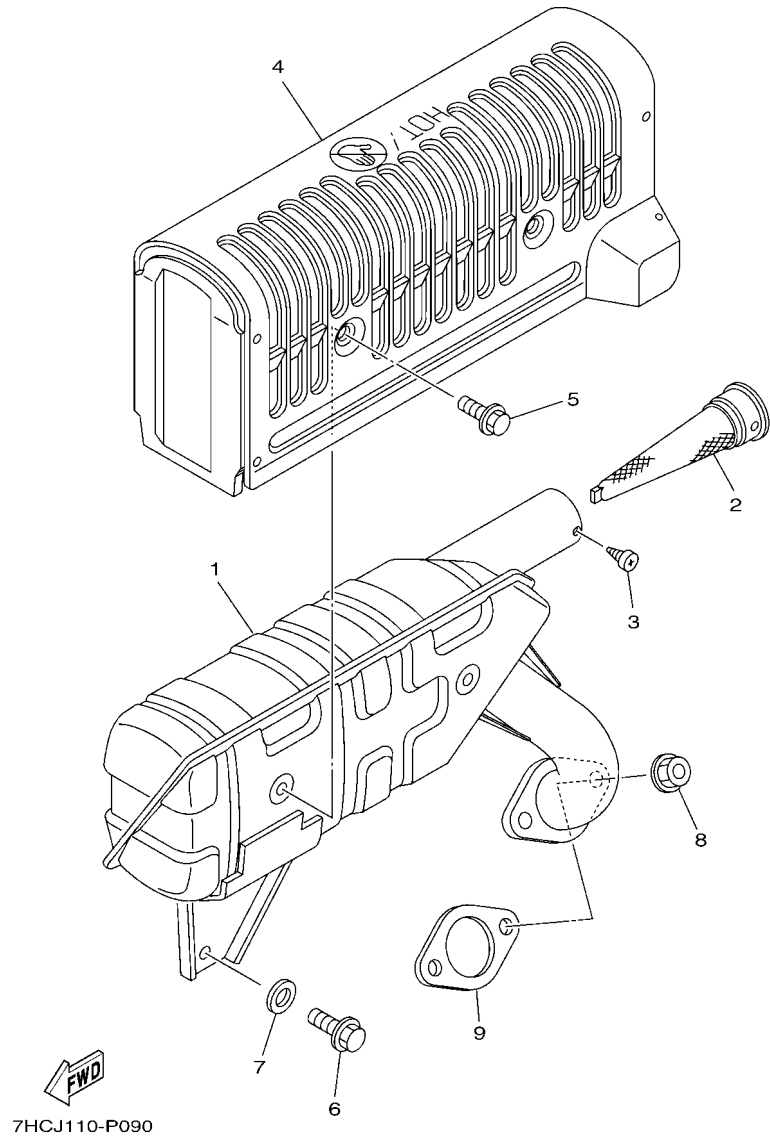

REF. NO.	PART NO.	DESCRIPTION	7HSJ				REMARKS
1	7HC-E4721-00	MUFFLER 2	1				
2	7BY-E4786-00	ARRESTER, SPARK	1				
3	97702-40506	SCREW, TAPPING	1				
4	7HC-E4708-00	PROTECTOR ASSY	1				
5	95822-06008	BOLT, FLANGE	4				
6	95822-08016	BOLT, FLANGE	1				
7	90201-08856	WASHER, PLATE	1				
8	95302-08600	NUT, HEXAGON	2				
9	7HC-E4613-00	GASKET, EXHAUST PIPE	1				

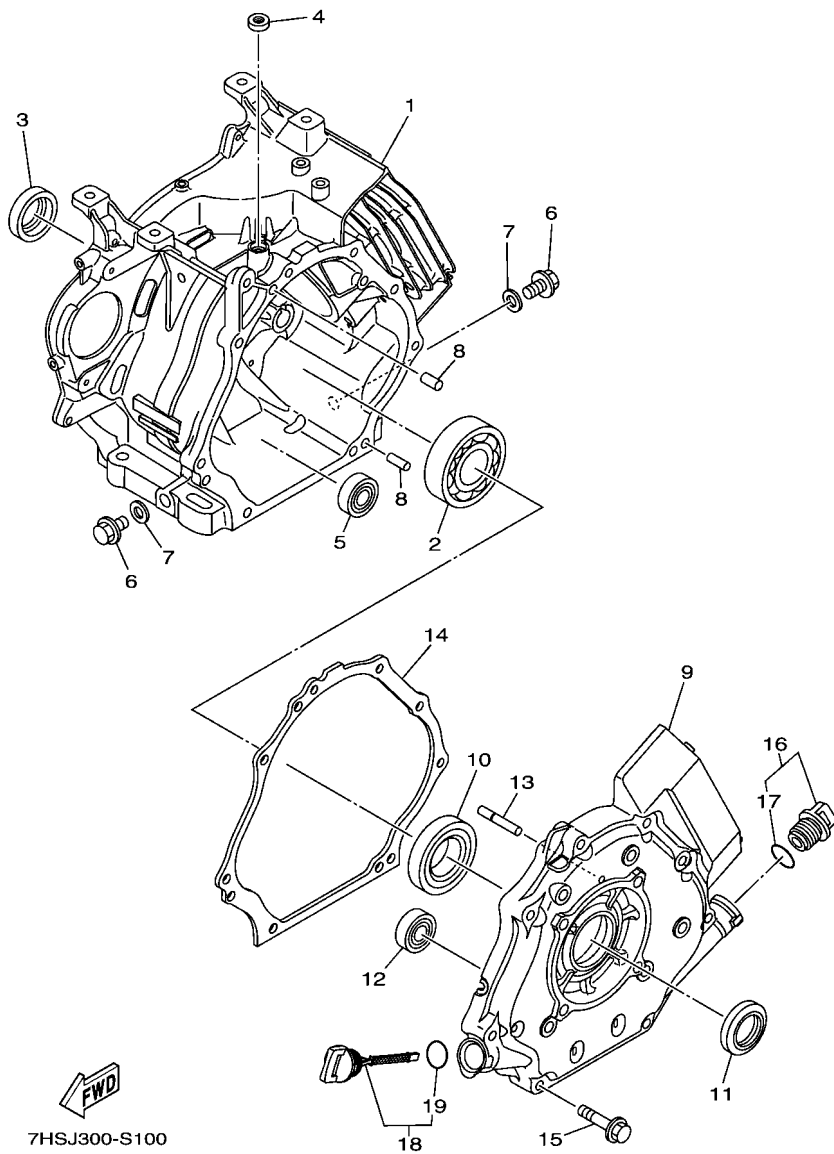
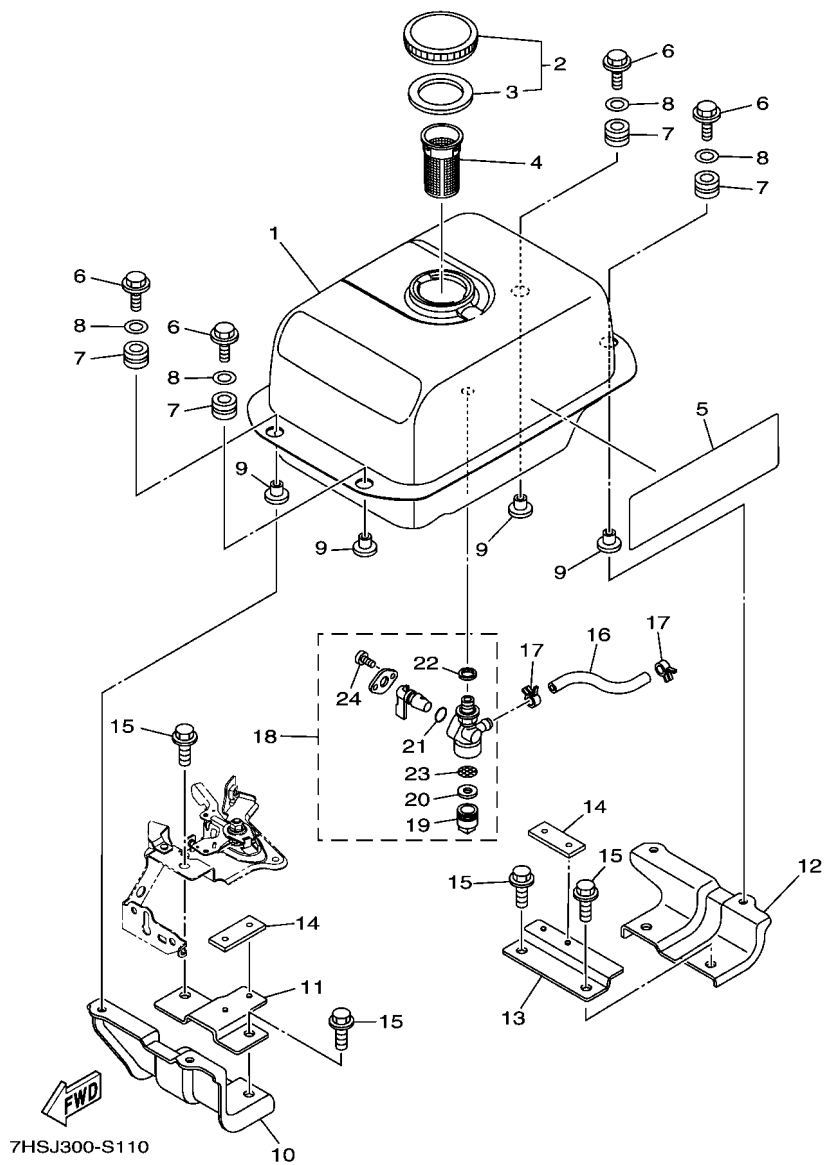

FIG. 10 CRANKCASE

REF. NO.	PART NO.	DESCRIPTION	7HSJ				REMARKS
1	7HC-E5111-11	CRANKCASE 1	1				
2	93306-307Y1	BEARING	1				
3	93102-35802	OIL SEAL	1				
4	93109-08803	OIL SEAL	1				
5	93306-252YK	BEARING	1				
6	90340-12097	PLUG, STRAIGHT SCREW	2				
7	7CT-E1198-00	GASKET	2				
8	99530-08016	PIN, DOWEL	2				
9	7HC-E5411-00	COVER, CRANKCASE 1	1				
10	93306-207Y2	BEARING	1				
11	93102-35802	OIL SEAL	1				
12	93306-252YK	BEARING	1				
13	7CT-E1971-00	SHAFT, FLYWEIGHT	1				
14	7HD-E5451-10	GASKET, CRANKCASE COVER 1	1				
15	95812-08045	BOLT, FLANGE	8				
16	7BX-E536A-20	PLUG, OIL LEVEL	1				
17	93210-22805	.O-RING	1				
18	7VB-E536A-00	PLUG, OIL LEVEL	1				
19	93210-22805	.O-RING	1				

FIG. 11 FUEL TANK



REF. NO.	PART NO.	DESCRIPTION	7HSJ				REMARKS
1	7HC-F4110-10	FUEL TANK COMP.	1				
2	7CN-F4610-01	CAP ASSY	1				
3	7CN-F4612-01	.PACKING, CAP	1				
4	7CN-F4167-00	STRAINER	1				
5	7HP-F414G-00	SEAL	1				
6	7CT-F4176-00	BOLT 1	4				
7	90480-15235	GROMMET	4				
8	90201-06085	WASHER, PLATE	4				
9	90387-068K8	COLLAR	4				
10	7HC-F4115-10	STAY, FUEL TANK 1	1				
11	7HC-F4117-00	STAY, FUEL TANK 3	1				
12	7HC-F4116-10	STAY, FUEL TANK 2	1				
13	7HC-F4118-00	STAY, FUEL TANK 4	1				
14	7VB-F4181-00	DAMPER, LOCATING 1	2				
15	95812-08020	BOLT, FLANGE	4				
16	90445-10456	HOSE (L95)	1				
17	90467-09806	CLIP	2				
18	7CN-F4500-01	FUEL COCK ASSY 1	1				
19	7J3-24521-00	.CUP, FILTER	1				
20	4X8-24565-10	.GASKET	1				
21	7NJ-24534-00	.SEAL, COCK	1				
22	7NJ-24532-10	.GASKET	1				
23	7NJ-24515-01	.NET, FILTER 2	1				
24	98587-03008	.SCREW, PAN HEAD	2				

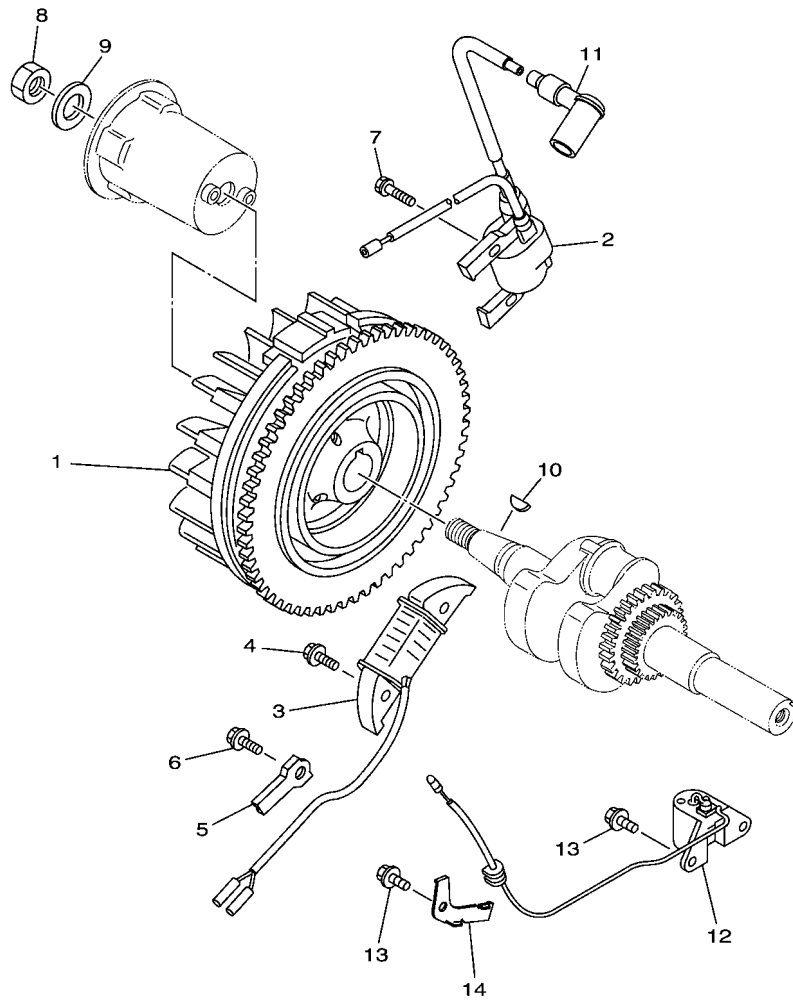

7HSJ110-R120

FIG. 12 TCI MAGNETO

REF. NO.	PART NO.	DESCRIPTION	7HSJ				REMARKS
1	7CU-H5650-00	ROTOR ASSY	1				
2	7CT-H5640-01	T.C.I. UNIT ASSY	1				
3	7CU-H5521-10	COIL ASSY	1				
4	95802-06025	BOLT, FLANGE	2				
5	90462-06232	CLAMP	1				
6	95802-06012	BOLT, FLANGE	1				
7	95880-06020	BOLT, FLANGE	2				
8	90170-18391	NUT	1				
9	90201-18802	WASHER, PLATE	1				
10	90280-04801	KEY, WOODRUFF	1				
11	7CN-H2370-00	PLUG CAP ASSY	1				
12	7HD-H5720-00	OIL LEVEL GAUGE ASSY	1				
13	95822-06012	BOLT, FLANGE	3				
14	7CN-H5724-10	CLAMP	1				

FIG. 13 STARTING MOTOR

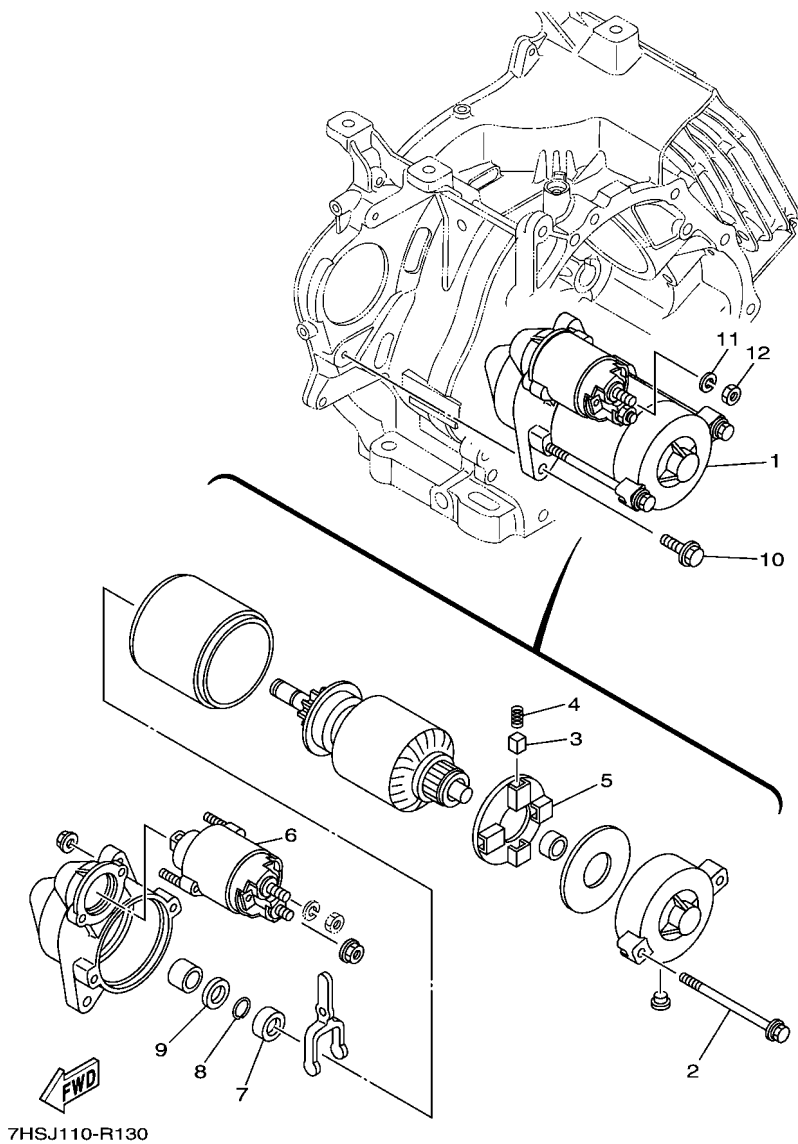

REF. NO.	PART NO.	DESCRIPTION	7HSJ				REMARKS
1	7CU-H1800-11	STARTING MOTOR ASSY	1				
2	7CU-H1826-00	.BOLT	2				
3	7CU-H1812-00	.BRUSH 2	4				
4	7CU-H1813-00	.SPRING, BRUSH	4				
5	7CU-H1840-00	.BRUSH HOLDER ASSY	1				
6	7CU-H1870-00	.STARTING SWITCH ASSY	1				
7	7CU-H1833-00	.RING, STOP	1				
8	7CU-H1834-00	.RING	1				
9	7CU-H1835-00	.WASHER	1				
10	95802-08025	BOLT, FLANGE	2				
11	92902-08100	WASHER, SPRING	1				
12	95302-08600	NUT, HEXAGON	1				

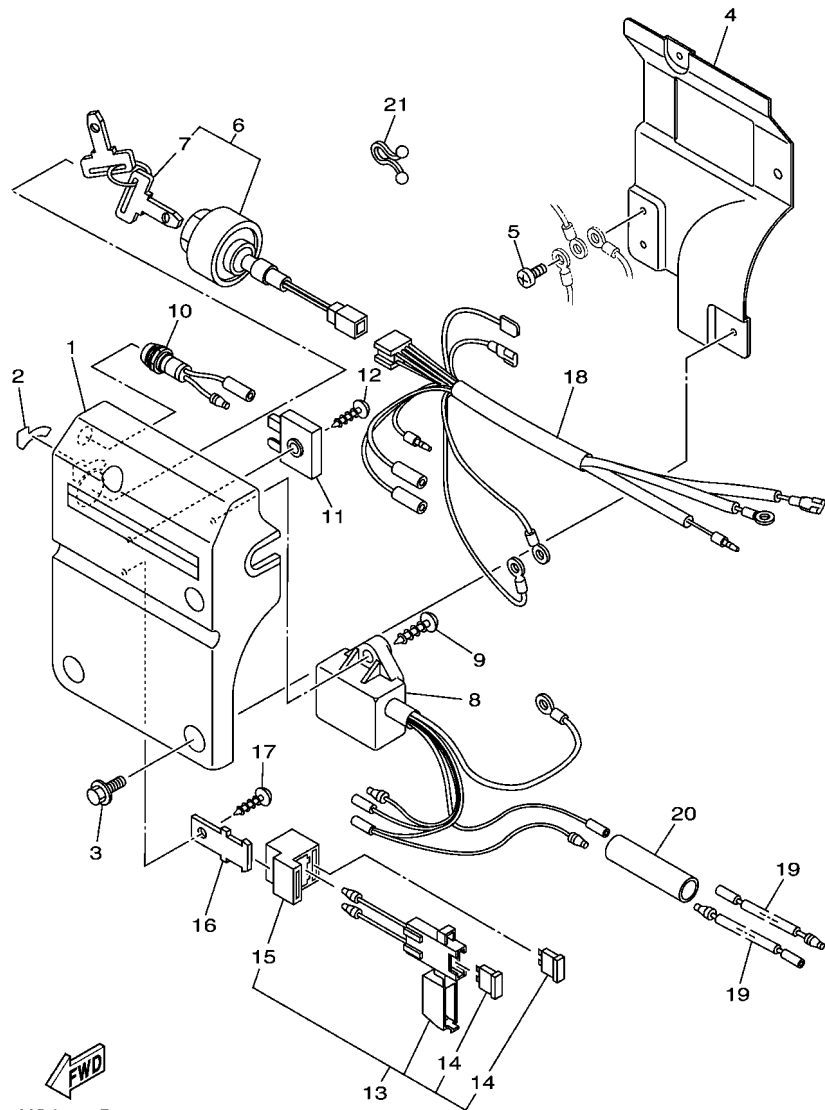

7HSJ110-R140

FIG. 14 ELECTRICAL

REF. NO.	PART NO.	DESCRIPTION	7HSJ				REMARKS
1	7HD-H2568-00	COVER, MAIN SWITCH	1				
2	7HD-F4156-00	INDICATOR, STARTER LEVER	1				
3	95822-06014	BOLT, FLANGE	4				
4	7HD-H251P-00	BRACKET, MAIN SWITCH	1				
5	98902-06012	SCREW, BIND	1				
6	7CU-H2510-00	MAIN SWITCH ASSY	1				
7	7CU-H2511-00	.KEY, MAIN SWITCH	2				
8	7CN-H5690-00	OIL WARNING UNIT	1				
9	97702-60025	SCREW, TAPPING	1				
10	7CA-H5770-01	OIL PILOT LIGHT ASSY	1				
11	7CU-H1970-01	RECTIFIER ASSY	1				
12	97702-50120	SCREW, TAPPING	1				
13	7CU-H2150-01	FUSE HOLDER ASSY	1				
14	7CU-H2151-00	.FUSE	2				
15	7CU-H2155-00	.BAND	1				
16	7CU-H2588-00	PLATE	1				
17	97702-50112	SCREW, TAPPING	1				
18	7CU-H2507-10	WIRE, LEAD	1				
19	7CP-H2507-00	WIRE, LEAD	2				
20	7CT-H2139-00	TUBE	1				
21	90464-11806	CLAMP	1				

FIG. 15 BODY FITTING

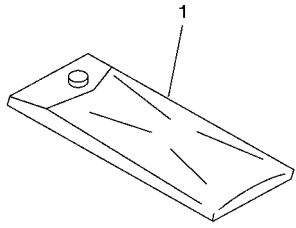

REF. NO.	PART NO.	DESCRIPTION	7HSJ	REMARKS
1	7CT-F8100-00	TOOL KIT	1	

7WR1400-1260

NUMERICAL INDEX

PART NO.	REF. NO.	PART NO.	REF. NO.	PART NO.	REF. NO.	PART NO.	REF. NO.	PART NO.	REF. NO.	PART NO.	REF. NO.
7NJ-24515-01	11 - 23	7HC-E3567-00	7 - 3	7CT-E5751-00	6 - 16	7HD-H5720-00	12 - 12	95802-06012	6 - 5		
7J3-24521-00	11 - 19	7CT-E3596-00	7 - 1	7CN-E5755-00	6 - 17	7CN-H5724-10	12 - 14		12 - 6		
7NJ-24532-10	11 - 22	7HC-E4117-00	8 - 20	7CN-E5755-00	6 - 15	7CA-H5770-01	14 - 10	95802-06016	6 - 18		
7NJ-24534-00	11 - 21	7HC-E4150-00	8 - 19	7HC-F4110-10	11 - 1	90113-05800	5 - 12		7 - 13		
4X8-24565-10	11 - 20	7HC-E4159-00	8 - 17	7HC-F4115-10	11 - 10	90170-05806	5 - 10	95802-06025	12 - 4		
7HD-E1111-10	1 - 1	7HC-E4162-00	8 - 16	7HC-F4116-10	11 - 12	90170-18391	12 - 8	95802-08025	13 - 10		
7CT-E1166-00	1 - 10	7HC-E4184-00	8 - 8	7HC-F4117-00	11 - 11	90173-06802	4 - 13	95812-08020	11 - 15		
7HD-E1181-00	1 - 2	7HC-E4185-00	8 - 9	7HC-F4118-00	11 - 13	90175-06809	7 - 9	95812-08045	10 - 15		
7HD-E1190-10	1 - 7	7BX-E4186-00	8 - 18	7HP-F414G-00	11 - 5	90201-06085	11 - 8	95812-10070	1 - 3		
7HD-E1193-00	1 - 8	7HC-E4191-00	8 - 14	7HC-F4154-00	16 - 4	90201-067L0	4 - 6	95822-06008	9 - 5		
7CT-E1198-00	10 - 7	7BX-E4212-00	8 - 5	7CN-F4155-00	16 - 1	90201-06842	4 - 4	95822-06012	12 - 13		
7HP-E1400-10	2 - 1		8 - 13	7HD-F4156-00	14 - 2	90201-08856	9 - 7	95822-06014	14 - 3		
7HP-E1454-00	3 - 7	7BX-E4216-00	8 - 3	7CN-F4162-20	16 - 3	90201-08858	4 - 9	95822-06030	1 - 9		
7CT-E1561-00	3 - 8	7HC-E4227-00	8 - 15	7CN-F4167-00	11 - 4	90201-18802	12 - 9	95822-08016	9 - 6		
7HD-E1610-00	3 - 2	7HC-E4239-00	8 - 21	7CT-F4176-00	11 - 6	90280-04801	12 - 10	95880-06020	12 - 7		
7HD-E1610-10	3 - 2	7HP-E4301-01	8 - 1	7VB-F4181-00	11 - 14	90282-06037	2 - 2	97522-06530	4 - 12		
7HD-E1610-20	3 - 2	7HC-E4411-00	7 - 4	7CN-F4500-01	11 - 18	90340-12097	10 - 6	97702-40506	9 - 3		
7HD-E1631-10-AO	3 - 1	7HC-E4412-00	7 - 5	7CN-F4610-01	11 - 2	90387-068K8	11 - 9	97702-50112	14 - 17		
7HD-E1633-00	3 - 3	7HC-E4430-01	7 - 6	7CN-F4612-01	11 - 3	90445-10456	11 - 16	97702-50120	14 - 12		
7HD-E1635-10	3 - 1	7HC-E4439-00	7 - 10	7CT-F8100-00	15 - 1	90462-06232	12 - 5	97702-60025	14 - 9		
7HD-E1636-10	3 - 1	7HC-E4450-00	7 - 7	7PB-F817K-00	16 - 5	90464-11806	14 - 21	98502-05030	4 - 17		
7HP-E1650-00	3 - 5	7HC-E4457-00	7 - 8	7HC-G1240-00	4 - 16	90467-09806	11 - 17	98587-03008	11 - 24		
7CT-E1654-00	3 - 6	7BX-E4486-00	8 - 2	7CU-H1800-11	13 - 1	90468-12801	4 - 10	98902-06012	14 - 5		
7CT-E1913-00	4 - 2	7HP-E4499-00	7 - 11	7CU-H1812-00	13 - 3	90480-15235	11 - 7	99530-08016	10 - 8		
7CT-E1914-00	4 - 3	7HC-E4583-00	8 - 4	7CU-H1813-00	13 - 4	90501-090A8	4 - 18	99530-14016	1 - 4		
7CT-E1917-00	4 - 7	7HC-E4613-00	9 - 9	7CU-H1826-00	13 - 2	90501-264A9	5 - 5				
7CT-E1922-00	4 - 8	7HC-E4708-00	9 - 4	7CU-H1833-00	13 - 7	90506-04006	4 - 15				
7HC-E1924-10	4 - 11	7HC-E4721-00	9 - 1	7CU-H1834-00	13 - 8	90506-14804	4 - 19				
7HC-E1928-00	4 - 14	7BY-E4786-00	9 - 2	7CU-H1835-00	13 - 9	92902-08100	13 - 11				
7CT-E1970-10	4 - 1	7HC-E4922-00	8 - 6	7CU-H1840-00	13 - 5	93102-35802	10 - 3				
7CT-E1971-00	10 - 13	7HP-E4A41-00	8 - 11	7CU-H1870-00	13 - 6		10 - 11				
7CT-E2111-00	5 - 2	7HC-E4A42-79	8 - 7	7CU-H1970-01	14 - 11	93109-08803	10 - 4				
7CT-E2117-00	5 - 6	7HC-E4A43-65	8 - 12	7CT-H2139-00	14 - 20	93210-22805	10 - 17				
7CT-E2118-00	5 - 7	7HC-E4A81-00	8 - 10	7CU-H2150-01	14 - 13		10 - 19				
7CT-E2119-00	5 - 14	7HC-E5111-11	10 - 1	7CU-H2151-00	14 - 14	93306-207Y2	10 - 10				
7HD-E2121-00	5 - 3	7VB-E536A-00	10 - 18	7CU-H2155-00	14 - 15	93306-252YK	10 - 5				
7CT-E2151-00	5 - 8	7BX-E536A-20	10 - 16	7CN-H2370-00	12 - 11		10 - 12				
7CT-E2153-00	5 - 4	7HC-E5411-00	10 - 9	7CP-H2507-00	14 - 19	93306-307Y1	10 - 2				
7HD-E2154-00	5 - 13	7HD-E5451-10	10 - 14	7CU-H2507-10	14 - 18	93440-06826	4 - 5				
7HD-E2156-00	5 - 11	7HC-E5710-00	6 - 7	7CU-H2510-00	14 - 6	93450-22840	3 - 4				
7CT-E2159-00	5 - 9	7HC-E5713-00	6 - 10	7CU-H2511-00	14 - 7	94702-00819	1 - 6				
7HD-E2170-00	5 - 1	7HC-E5714-00	6 - 8	7HD-H251P-00	14 - 4	95302-08600	9 - 8				
7HC-E261H-00	6 - 6	7HC-E5715-00	6 - 11	7HD-H2568-00	14 - 1		13 - 12				
7HD-E2621-00	6 - 1	7HC-E5716-00	6 - 14	7CU-H2588-00	14 - 16	95602-08710	1 - 11				
7HP-E2629-00	16 - 2	7HC-E5719-00	6 - 12	7CU-H5521-10	12 - 3	95622-08618	1 - 5				
7HC-E2651-00	6 - 3	7HC-E5723-00	6 - 19	7CT-H5640-01	12 - 2	95702-08500	7 - 12				
7HC-E2652-00	6 - 4	7HC-E5741-00	6 - 9	7CU-H5650-00	12 - 1	95802-06012	4 - 20				
7CT-E3557-00	7 - 2	7HC-E5743-00	6 - 13	7CN-H5690-00	14 - 8		6 - 2				