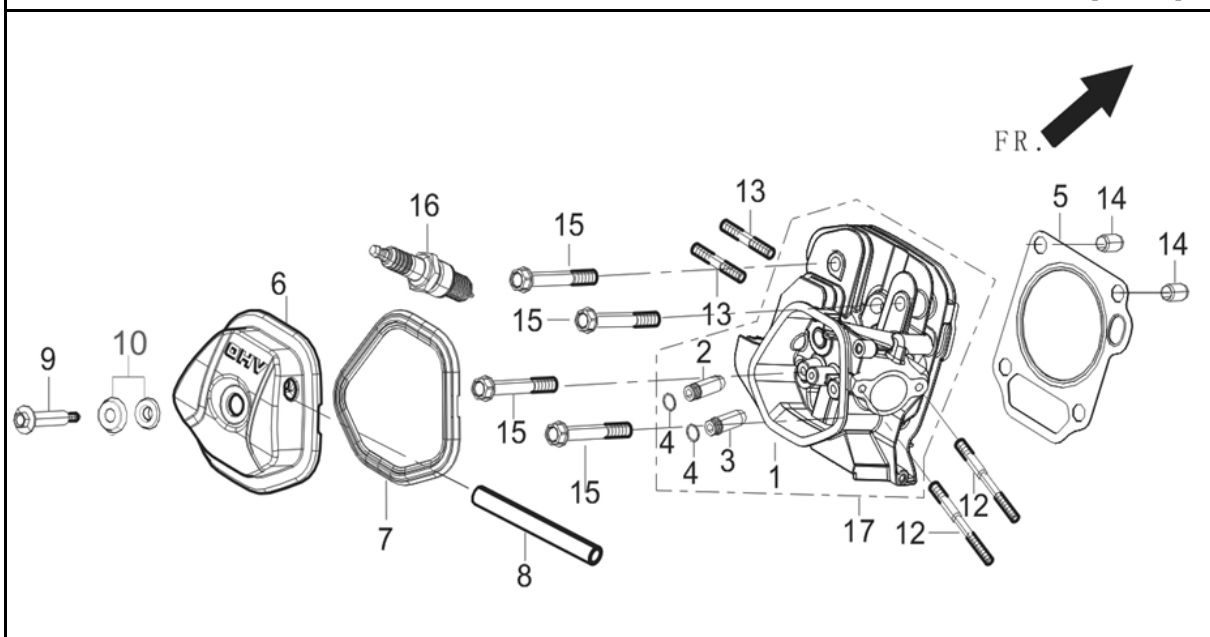
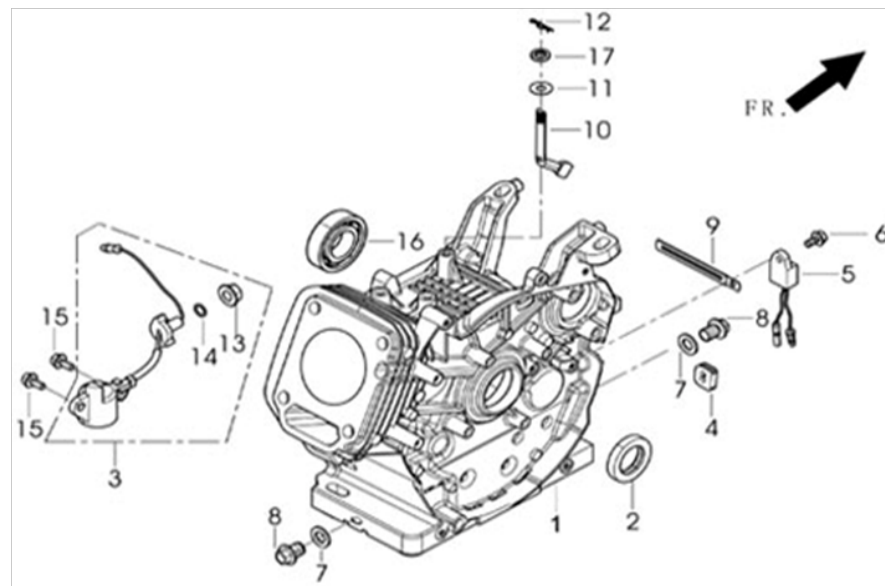

FIG.1 CYLINDER HEAD , CYLINDER COVER ASSY (E04)



REF.NO.	PART NO	DESCRIPTION	Q'TY
E04-5	12131-Z100110-0000	GASKET, CYLINDER HEAD	1
E04-6	12410-Z080410-0000	COVER SUBASSEMBLY, CYLINDER HEAD	1
E04-7	12004-Z080110-0000	GASKET, CYLINDER HEAD COVER	1
E04-8	17004-Z080510-0000	TUBE, BREATHER	1
E04-9	12032-Z080110-0100	BOLT, CYLINDER HEAD	1
E04-10	12034-Z080110-0099	BOLT SUBASSEMBLY, CYLINDER HEAD COVER	1
E04-12	90204-Z100510-0000	STUD	2
E04-13	90203-Z010110-0000	STUD	2
E04-14	90502-1220-00	PIN	2
E04-15	12003-Z080110-0000	BOLT, CYLINDER HEAD	4
E04-16	30010-Z010110-0000	PLUG, SPARK	1
E04-17	12140-Z100410-0B00	HEAD SUBASSEMBLY, CYLINDER	1

FIG.2 CRANKCASE (E17)



REF.NO.	PART NO	DESCRIPTION	Q'TY
E17-1	11310-Z101310-0B00	CRANKCASE SUBASSEMBLY.	1
E17-2	90682-Z310110-0000	SEAL, OIL	1
E17-3	37060-Z080120-0000	SENSOR, ENGINE OIL	1
E17-4	28101-Z080110-0000	PLUG, RUBBER	1
E17-5	37050-Z010210-0000	PROTECTOR, OIL	1
E17-6	90001-0612-01	BOLT	1
E17-7	90412-Z080110-0000	WASHER	2
E17-8	11007-Z080110-0000	BOLT, DRAIN PLUG	2
E17-9	90684-Z030120-0000	CLIP	1
E17-10	16061-Z100110-0000	ARM, GOVERNOR	1
E17-11	90412-Z080210-0000	WASHER	1
E17-12	90501-Z010110-0000	PIN	1
E17-13	90305-Z010210-01	NUT	1
E17-15	90001-0616-01	BOLT	2
E17-16	90548-0202-00	BEARING	1
E17-17	90682-Z100210-0000	SEAL, OIL	1

FIG.3 COVER, CRANKCASE (E01)

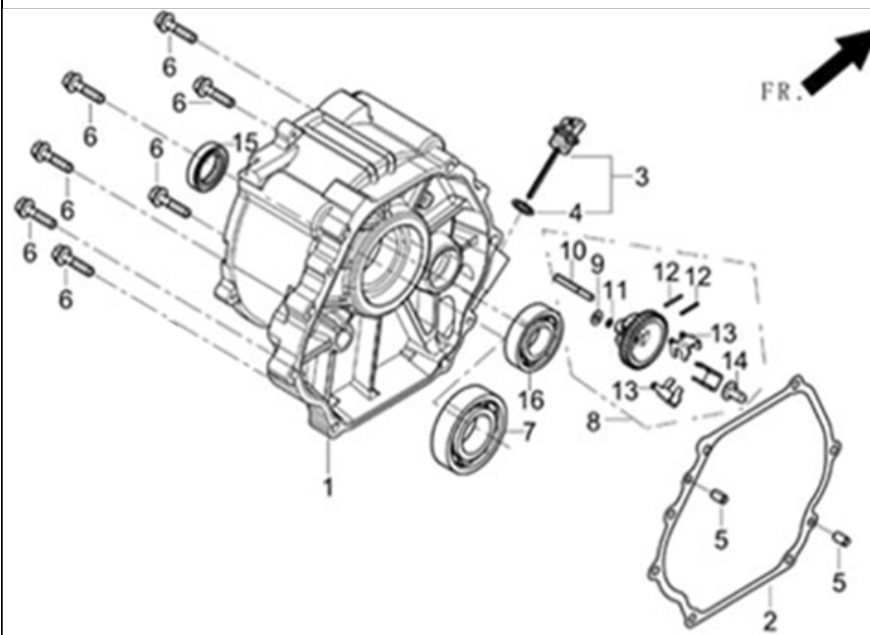

REF.NO.	PART NO	DESCRIPTION	Q'TY
E01-1	11411-Z101610-0B00	COVER, CRANKCASE	1
E01-2	11001-Z100120-0000	GASKET, CRANKCASE	1
E01-3	15010-Z080330-Q500	CAP COMP, OIL FILLER(YELLOW)	1
E01-5	90502-0812-00	PIN	2
E01-6	90001-0840-01	BOLT	7
E01-7	90547-0207-00	BEARING	1
E01-8	16400-Z100110-0000	GEAR ASSY, GOVERNOR	1
E01-15	90682-Z310110-0000	OIL SEAL	1
E01-16	90548-0202-00	BEARING	1

FIG.4 CRANKSHAFT ASSY.(E03)

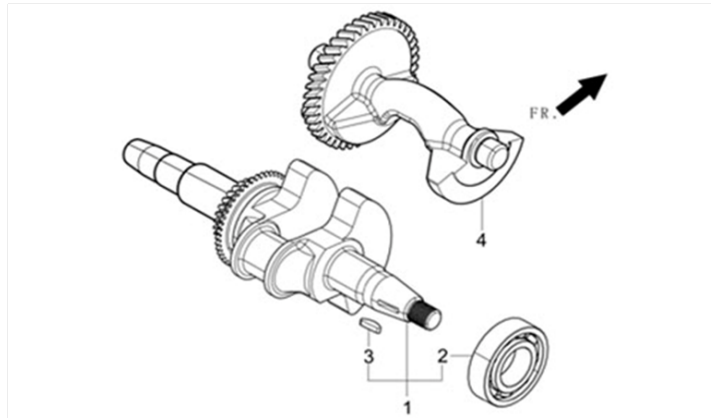

REF.NO.	PART NO	DESCRIPTION	Q'TY
E03-1	13300-Z100110-RB00	CRANKSHAFT ASSY.	1
E03-4	13401-Z100110-0000	WEIGHT, BALANCER	1

FIG.5 PISTON/CONNECTING ROD (E03)

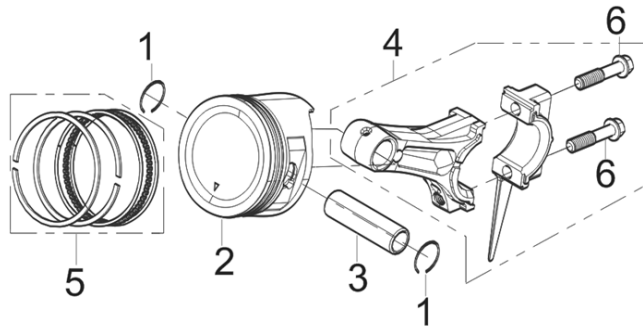

REF.NO.	PART NO	DESCRIPTION	Q'TY
E03-1	13122-Z100110-0000	CLIP, PISTON PIN	2
E03-2	13111-Z100410-0099	PISTON	1
E03-3	13121-Z100110-0000	PIN, PISTON	1
E03-4	13010-Z100120-0000	ROD, CONNECTING	1
E03-5	13200-Z100110-0099	PISTON RINGS SET	1

FIG.6 CAMSHAFT ASSY. (E05)

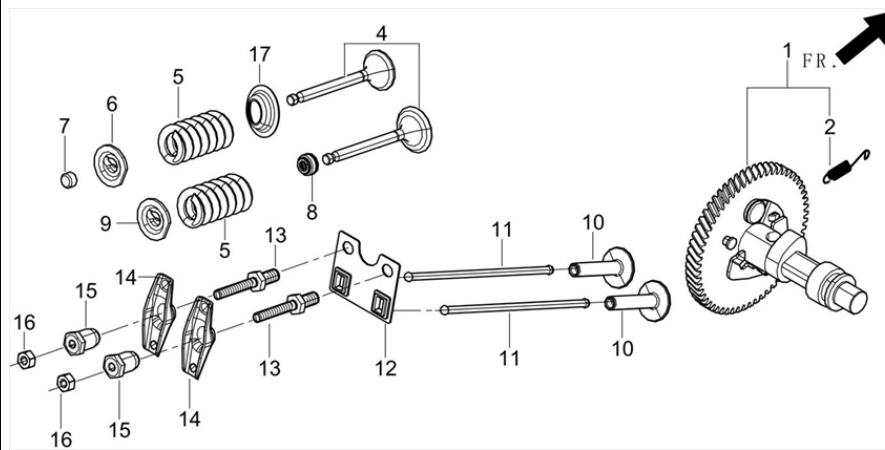

REF.NO.	PART NO	DESCRIPTION	Q'TY
E05-1	14200-Z100110-0000	CAMSHAFT ASSY.	1
E05-4	12110-Z100110-0000	VALVE	1
E05-5	12103-Z080110-0000	SPRING, VALVE	2
E05-6	12107-Z080110-0000	RETAINER , EXHAUST VALVE	1
E05-7	12104-Z080110-0000	RATATOR, VALVE	1
E05-8	12101-Z080110-0000	GUIDE, SEAL	1
E05-9	12112-Z080110-0000	RETAINER, VALVE SPRING	1
E05-10	14081-Z080110-0000	LIFTER, VALVE	2
E05-11	14070-Z100110-0000	TAPPET, VALVE	2
E05-12	14090-Z080110-0000	PLATE SUBASSEMBLY, LIFTER STOPPER	1
E05-13	14313-Z010110-0000	BOLT, VALVE ADJUSTING	2
E05-14	14311-Z080110-0000	ROCKER, VALVE	2
E05-15	14314-Z010110-0000	NUT, VALVE ADJUSTING	2
E05-16	14312-Z010110-0000	NUT, VALVE LOCK	2
E05-17	12105-Z080110-0000	RETAINER, VALVE SPRING	1

FIG.7 STARTER (E08)

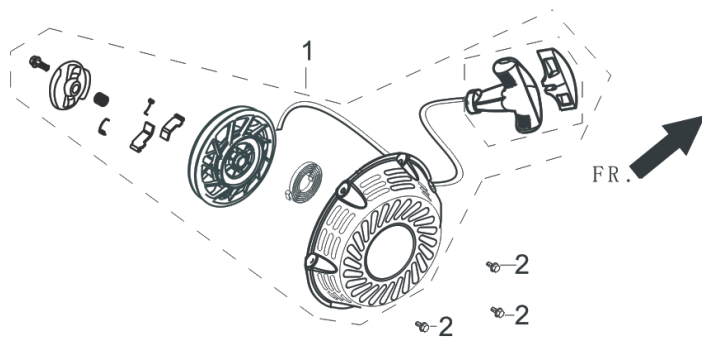

REF.NO.	PART NO	DESCRIPTION	Q'TY
E08-1	28200-Z100610-H300	STARTER ASSY, RECOIL	1
E08-2	90001-0608-01	BOLT	3

FIG.8 SHROUD (E14)

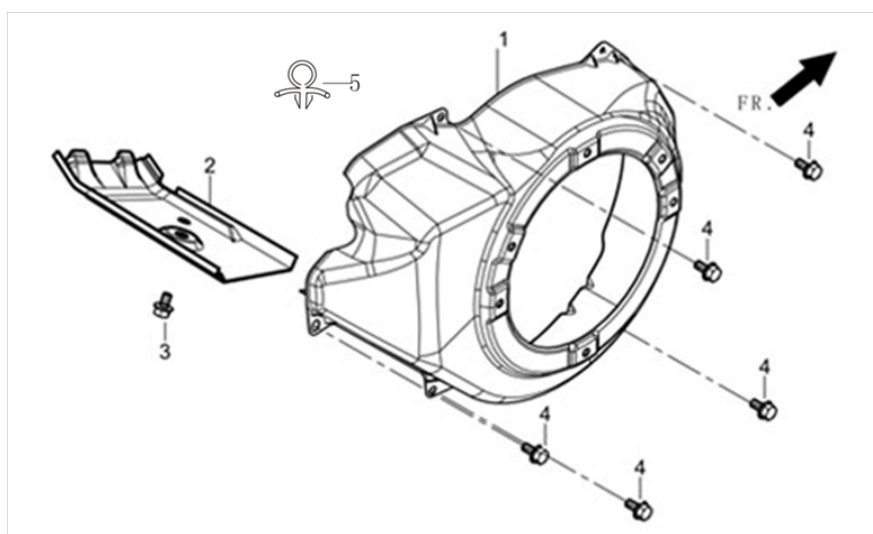

REF.NO.	PART NO	DESCRIPTION	Q'TY
E14-1	28110-Z100510-H300	SHROUD	1
E14-2	19304-Z110110-0000	SHROUD, CYLINDER BODY	1
E14-3	90001-0612-01	BOLT	1
E14-4	90001-0612-01	BOLT	5
E14-5	90684-Z030210-0000	CLIP	1

FIG.9 CARBURETOR ASSY.(E11)

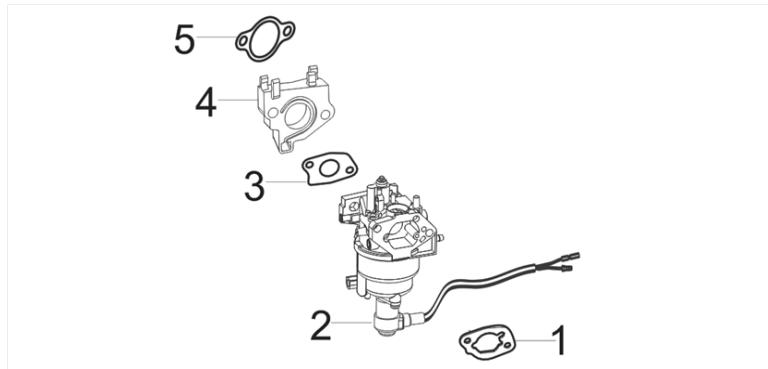

REF.NO.	PART NO	DESCRIPTION	Q'TY
E11-1	17001-Z080110-0000	GASKET, AIR CLEANER	1
E11-2	16100-Z100510-0000	CARBURETOR ASSY.	1
E11-3	16001-Z100110-0000	GASKET, CARBURETOR	1
E11-4	16003-Z100110-0000	PLATE, CARBURETOR INSULATOR	1
E11-5	17002-Z100110-0000	GASKET, INLET	1

FIG.10 AIR CLEANER (F02)

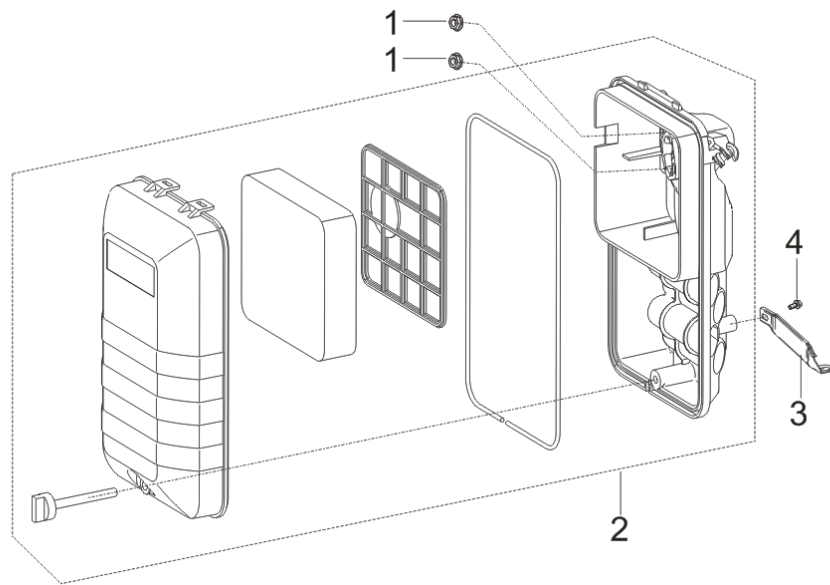

REF.NO.	PART NO	DESCRIPTION	Q'TY
F02-1	90305-0600-31	WASHER	2
F02-2	17100-Z101710-0000	CLEANER,AIR	1
F02-3	17003-Y030210-0000	SUPPORT , ATR CLEANER	1
F02-4	90001-0612-03	BOLT	1

FIG.11 MUFFLER ASSY.(F04)

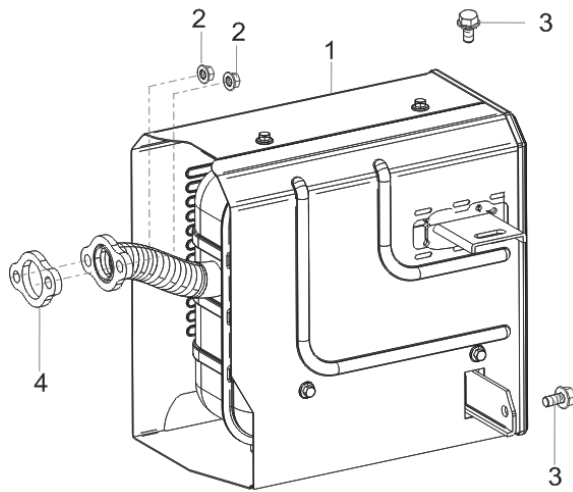

REF.NO.	PART NO	DESCRIPTION	Q'TY
F04-1	18100-Y720420-0000	MUFFLER ASSEMBLY	1
F04-2	90303-0800-33	NUT	2
F04-3	90001-0816-03	BOLT	2
F04-4	18001-Z080110-0000	GASKET, EXHAUST OUTLET	1

FIG.12 TANK, FUEL (F01)

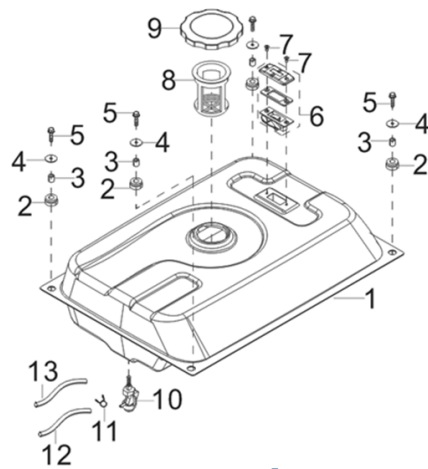

REF.NO.	PART NO	DESCRIPTION	Q'TY
F01-1	16620-Y032810-H708	TANK, FUEL(YELLOW)	1
F01-2	16601-Y020120-0000	SLEEVE, FUEL TANK RUBBER	4
F01-3	90683-Y020110-0000	BUSH	4
F01-4	90408-Y020110-0000	WASHER	4
F01-5	90007-0625-A3	BOLT(M6×25)	4
F01-6	37200-Y020210-H300	LEVELER ASSY, OIL(BLACK)	1
F01-7	90104-0512-53	SCREW	2
F01-8	16652-Y020120-0000	STRAINER , FUEL	1
F01-9	16730-Y020130-H700	COVER, FUEL TANK(BLACK)	1
F01-10	16750-Y020210-0000	COCK ASSY, FUEL	1
F01-11	90740-Z010210-0000	COLLAR	2
F01-12	90686-Z080410-0000	TUBE, FUEL	1
F01-13	30431-Y030110-0000	JACKET,RUBBER	1

FIG.13 FLYWHEEL SUBASSEMBLY (E15)

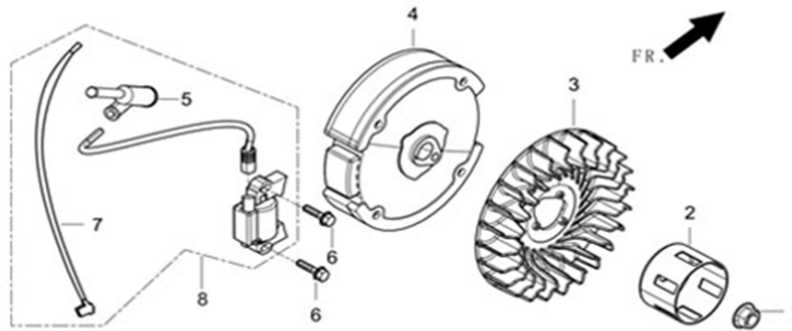

REF.NO.	PART NO	DESCRIPTION	Q'TY
E15-1	13501-Z080110-0000	NUT, FLYWHEEL	1
E15-2	28002-Z100210-0000	PULLEY,STARTER	1
E15-3	19352-Z100210-0000	IMPELLER	1
E15-4	13510-Z100120-0000	FLYWHEEL SUBASSEMBLY	1
E15-6	90001-0628-01	BOLT	2
E15-8	30400-Z080310-0100	COIL, IGNITION	1

FIG.14 CONTORL ASSY.(E13)

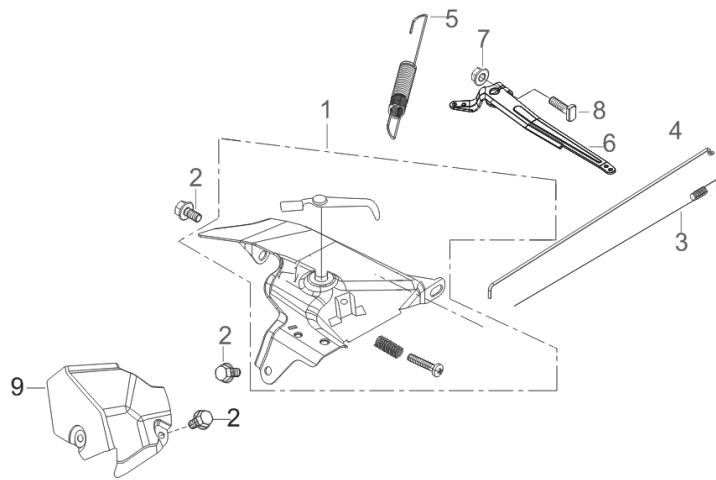

REF.NO.	PART NO	DESCRIPTION	Q'TY
E13-1	16520-Z101410-0000	CONTROL ASSY, THROTTLE	1
E13-2	90001-0610-01	BOLT	3
E13-3	16012-Z080110-0000	SPRING, THROTTLE VALVE RETURNING	1
E13-4	16062-Z100110-0000	ROD, GOVERNOR	1
E13-5	16063-Z100510-0000	SPRING, GOVERNOR	1
E13-6	16070-Z100120-0000	SUPPORT SUBASSEMBLY, GOVERNOR	1
E13-7	90305-0600-31	NUT	1
E13-8	16072-Z010110-0000	BOLT, GOVERNOR SUPPORT	1
E13-9	16673-Y0P0110-0000	protector	1

ACCESS 5500XL S2 (Jusqu'à A1810000062)

FIG.15 FRAME, ENGINE (F61)

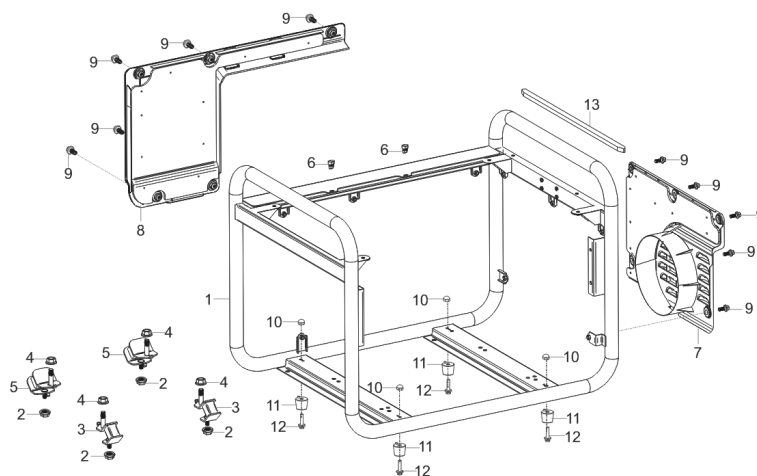

REF.NO.	PART NO	DESCRIPTION	Q'TY
F61-1	51100-Y052510-H7L0	FRAME ASSY, ENGINE	1
F61-2	90306-1000-31	NUT	4
F61-3	51005HY030120-0000	CUSHION, ENGINE FRAME	2
F61-4	90305-0800-31	NUT	4
F61-5	51012HY030120-0000	CUSHION, ENGINE FRAME REAR	2
F61-6	16602-Y020130-0000	rubber, fuel tank	2
F61-7	51025HY030110-Q200	decorating plate	1
F61-8	51026HY030110-Q200	decorating plate 2	1
F61-9	51138-Y030110-0000	fixing bolt, decorating plate	10
F61-10	90305-0600-33	NUT	4
F61-11	51014HY020120-0000	SEAT, ENGINE FRAME SHOCK ABSORPTION	2
F61-12	90001-0612-03	BOLT	4
F61-13	16603-Y030110-0000	bar, fuel tank	1

FIG.16 PANEL SUBASSEMBLY, CONTROL (F62)

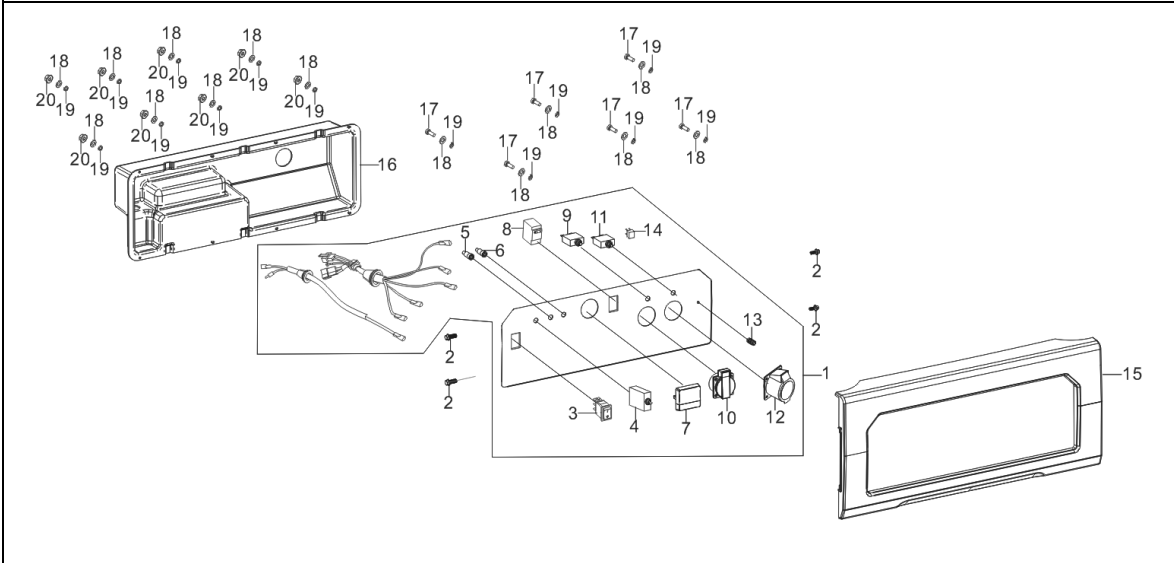

REF.NO.	PART NO	DESCRIPTION	Q'TY
F62-1	35610-Y056710-H300	PANEL SUBASSEMBLY, CONTROL	1
F62-2	90007-0612-A3	BOLT	4
F62-3	35160-Y020110-0000	SWITCH SUBASSEMBLY	1
F62-4	31234-Y020110-0000	PROTECTOR, OVERCURRENT	1
F62-5	35633-Y020110-0000	TERMINAL, POSITIVE ELECTRODE	1
F62-6	35634-Y020110-0000	TERMINAL, NEGATIVE ELECTRODE	1
F62-7	37114-Y280110-0000	VOLTMETER	1
F62-8	35648-Y050110-0000	earth leakage protector	1
F62-9	31234-Y050110-0000	PROTECTOR, OVERCURRENT	1
F62-10	35614-Y020110-0000	SOCKET SUBASSEMBLY, POWER SUPPLY	1
F62-11	31234-Y120110-0000	PROTECTOR, OVERCURRENT	1
F62-12	35614-Y240110-0000	SOCKET SUBASSEMBLY, POWER SUPPLY	1
F62-13	35629-Y2V0210-0000	TERMINAL SUBASSEMBLY, GROUNDING	1
F62-14	35621-Y020110-0000	BRIDGE, RECTIFICATION	1
F62-15	35680-Y030210-Q200	SEAT, PANEL	1
F62-16	35601-Y030120-Q200	CASE, PANEL REAR	1
F62-17	90106-0410-51	SCREW	6
F62-18	90408-0400-E1	WASHER	14
F62-19	90403-0400-01	WASHER	14
F62-20	90305-0400-71	NUT	8

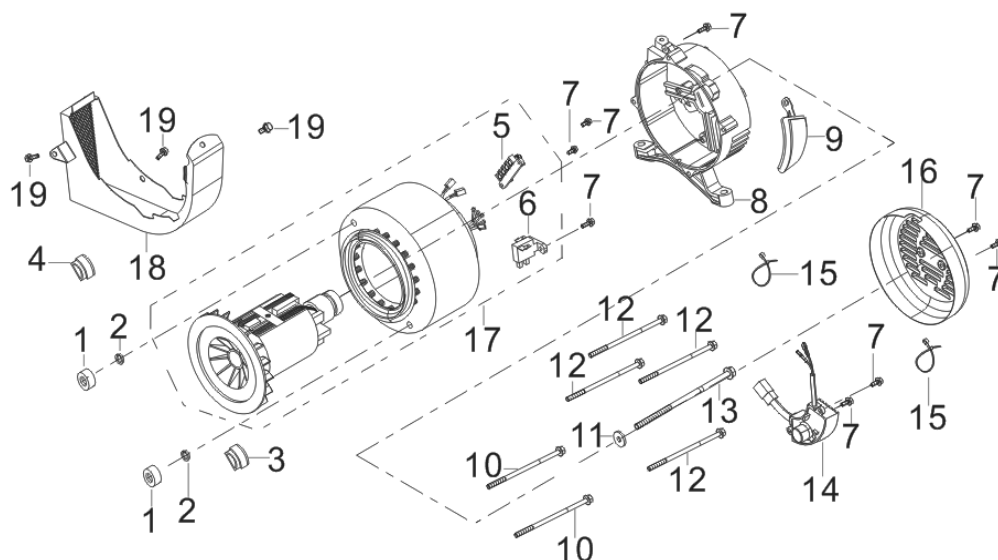
FIG.17 ROTOR/STATOR (F63)

REF.NO.	PART NO	DESCRIPTION	Q'TY
F63-1	31317-Y030110-0000	NUT , STATOR	2
F63-2	90403-0500-03	WASHER	2
F63-3	30023-Y030310-0000	STOPPER, MOTOR RIGHT COVER	1
F63-5	31303HY020110-0000	BLOCK, TERMINAL	1
F63-6	31320-Y030120-0000	BRUSH SUBASSEMBLY, CARBON	1
F63-7	90001-0516-01	BOLT	8
F63-8	30021-Y030310-0000	BRACKET, MOTOR	1
F63-9	30054-Y030110-Q200	water-proof cap, alternator bracket	1
F63-10	31316-Y030130-0000	BOLT , STATOR	2
F63-11	90408-Y030110-0000	WASHER	1
F63-12	30048-Y030120-0000	BOLT , STATOR	4
F63-13	30049-Y030120-0000	BOLT , ROTOR	1
F63-14	30060-Y030120-0000	REGULATOR, VOLTAGE	1
F63-15	90727-Y020110-0000	BAND	2
F63-16	30022-Y030110-H300	COVER, MOTOR TAIL	1
F63-17	31300-Y050410-0000	MOTOR ASSY.	1
F63-18	30024-Y030110-0000	SHROUD, MOTOR	1
F63-19	90001-0510-01	BOLT	3