

GMP JET100D L100

N°	Référence NAV	Désignation NAV	QUANTITE
100	ZCADGMP01-A	CHASSIS GMP01	1
110	ZCADGMP01-D	TRAVERSE GMP01	2
120	MER-909650	PLOT MD50 50 SHORE M12	4
130	ZCONTACTM8M	RONDELLE MOYENNE M8 ZBJ	8
140	ZVISTHM8X25	VIS TH M8*25 ZBJ	8
150	ZCONTACTM12M	RONDELLE MOYENNE M12 ZBJ	4
160	ZVISTHM12X30	VIS TH M12*30 ZBJ	4
170	ZECROUM8T/1	ECROU M8 TWOLOCK ETROIT	8
N°	Référence NAV	Désignation NAV	QUANTITE
1	ZCADGMP01-D	TRAVERSE GMP01	2
2	MER-909650	PLOT MD50 50 SHORE M12	4
3	ZCONTACTM8M	RONDELLE MOYENNE M8 ZBJ	1
4	ZVISTHM8X25	VIS TH M8*25 ZBJ	1
5	ZCONTACTM12M	RONDELLE MOYENNE M12 ZBJ	1
6	ZVISTHM12X30	VIS TH M12*30 ZBJ	1
7	ZECROUM8T/1	ECROU M8 TWOLOCK ETROIT	1
8	ZCONTACTM6M	RONDELLE MOYENNE M6 ZBJ	1
9	ZECROUBAGM6	ECROU BAG NYLON M6 ZING	1
10	ZVISBHCIM8X60	VIS BHC M8*60 INOX	1
11	ZVISBHCIM8X16	VIS BHC M8*16 INOX	1
12	ZVISTHM8X40	VIS TH M8*40 ZBJ	1
13	ZECROUM8T/2	ECROU M8 TWOLOCK LARGE	1
14	ZVISTHM8X25	VIS TH M8*25 ZBJ	1
15	ZVISTHM8X50	VIS TH M8*50 ZBJ	1
16	ZVISTHM6X16	VIS TH M6*16 ZBJ	1
17	ZVISBHCEIM6X16	VIS BHC M6*16 EMBASE INOX	1
18	ZCADGMP01-G	SUPPORT BATTERIE GMP01	1
20	ZBATT12V24A	BATTERIE 12V 28 AH	1
21	ZCADGMP01-H	CAPOT BATTERIE GMP01	1
22	ZPOIGNEE01	POIGNEE EN U ENT.117 H50 M6	1
23	ZVISTHM5X16	VIS TH M5*16 ZBJ	1
24	ZCONTACTM5M	RONDELLE MOYENNE M5 ZBJ	1
25	ZCADL100-SUP-RELA	SUPPORT RELAI L100	1
26	ZSUP-MINIRELAI	SUPPORT MINI RELAI	2
27	643508	RELAIS VALEO	2
28	L100V6DA1F1HAWR	MOTEUR YANMAR L100V6 DPS SH	1
29	ZVISTHM8X70	VIS TH M8*70 ZBJ	1
30	114820-55900	TANK ASSY, FUEL OIL	1
31	066-00003-00	#N/A	1
32	QP-T206SLTD-KITL100	KIT DE POMPE JET 100D	1
33	ZCADGMP01-A	CHASSIS GMP01	1
51	ZSUPPORT-QP-T205SLT	SUPPORT KIT DE POMPE	1
52	ZVISTHM8X20	VIS TH M8*20 ZBJ	3

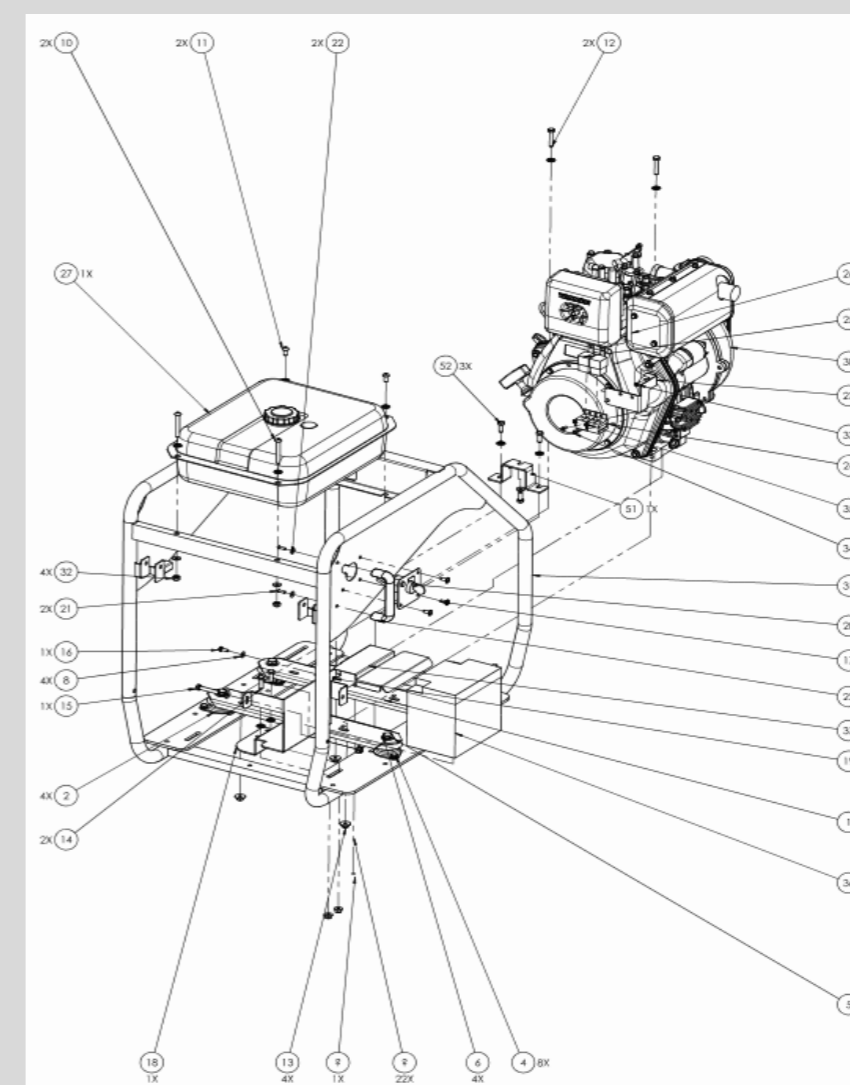
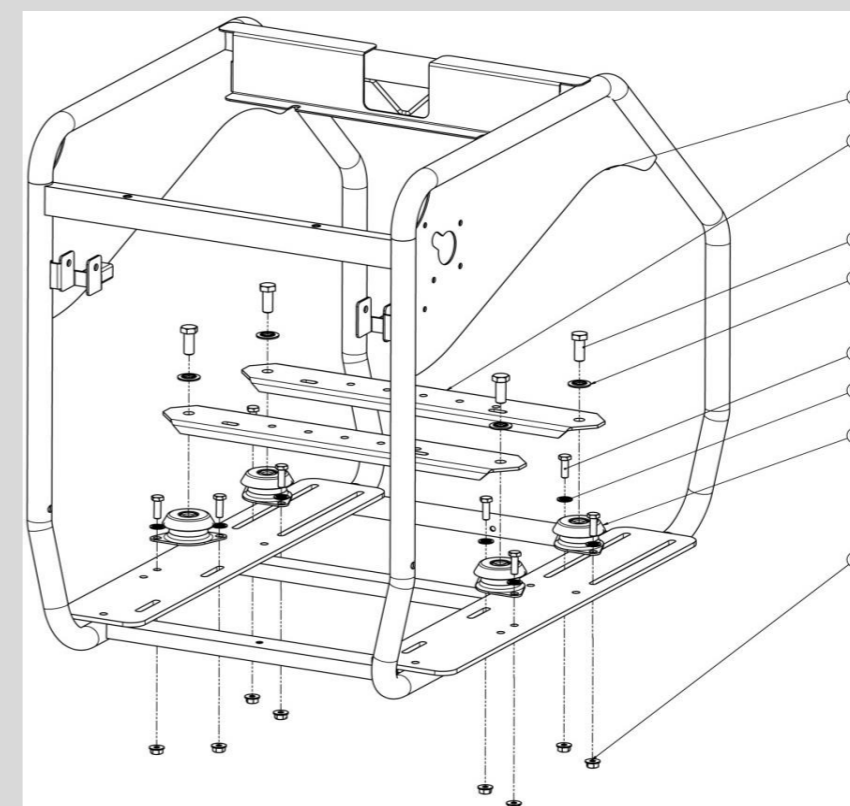

KIT POMPE JET100D

N°	Référence Fournisseur	Désignation NAV	QUANTITE
1	1378-1000108	CASING	1
2	1803-100160	SUCTION COVER	1
3	1378-350350	CHECK VALVE	1
4	7207-060130	VOLUTE CASING	1
5	7207-060040	IMPELLER	1
6	1878-081290	LINER RING 2	1
7	7207-060110	VOLUTE CASING 2	1
8	7207-060030	IMPELLER 2	1
9	7207-060120	VOLUTE CASING 3	1
10	7207-251240	IMPELLER WASHER	1
11	1882-221010	PUMP SHAFT	1
12	080311-2930	MECHANICAL SEAL	1
13	1988-100020	CASING COVER	1
15	1803-330360	DELIVERY COVER PACKING	1
16	2261-000600-0011	CASING COVER SET PLATE	1
18	063121-1100	FLOODING CAP	1
19	048035-0300	O-RING(FLOODING CAP)	1
20	063121-1100	FLOODING CAP	1
21	048035-0300	O-RING(FLOODING CAP)	1
22	048935-2550	O-RING	1
24	051004-0443	KEY	1
25	1814-100091	DELIVERY COVER (3 WAY OUTLET)	1
26	048220-0750	O-RING	1
27	045822-0080	SEAL WASHER	4
28	1803-521220	LINER RING	1
29	010605-0825	BOLT	4
30	010505-0840	BOLT	4
31	045125-0080	SPRING WASHER	4
33	1806-998050	CHAIN CAP WITH PACKING(L)	1
34	1806-998070	CHAIN CAP WITH PACKING(S)	2
35	1814-209660ASSY2	BALL CHAIN	1
36	1814-209660ASSY	BALL CHAIN WITH CAP	1
41	045125-0080	SPRING WASHER	4
43	045129-0060	SPRING WASHER	2
44	010509-0640	BOLT	2
45	018105-0825	BOLT SET WITH SPRING WASHER	6
46	018105-0825	BOLT SET WITH SPRING WASHER	4
47	010605-0825	BOLT	4
48	018109-0820	BOLT SET WITH SPRING WASHER	1
53	7207-081300	LINER RING 3	1
59	074111-7050R	HOSE COUPLING SET	1
59-1	074131-0501	HOSE COUPLING PACKING	1
60	074111-8040	HOSE COUPLING SET	1
60-1	074131-0481	HOSE COUPLING PACKING	1
61	074111-9025	HOSE COUPLING SET	2
61-1	074131-0321	HOSE COUPLING PACKING	2
62	093225-2000	WIRE HOSE BAND	2
63	093225-1120	WIRE HOSE BAND	1
64	093225-1000	WIRE HOSE BAND	2
65	074230-1050R	STRAINER	1
66	092031-2013	NYLON NET	1
67	2261-220580	BEARING SPACER	1
68	067002-6909	BEARING	1

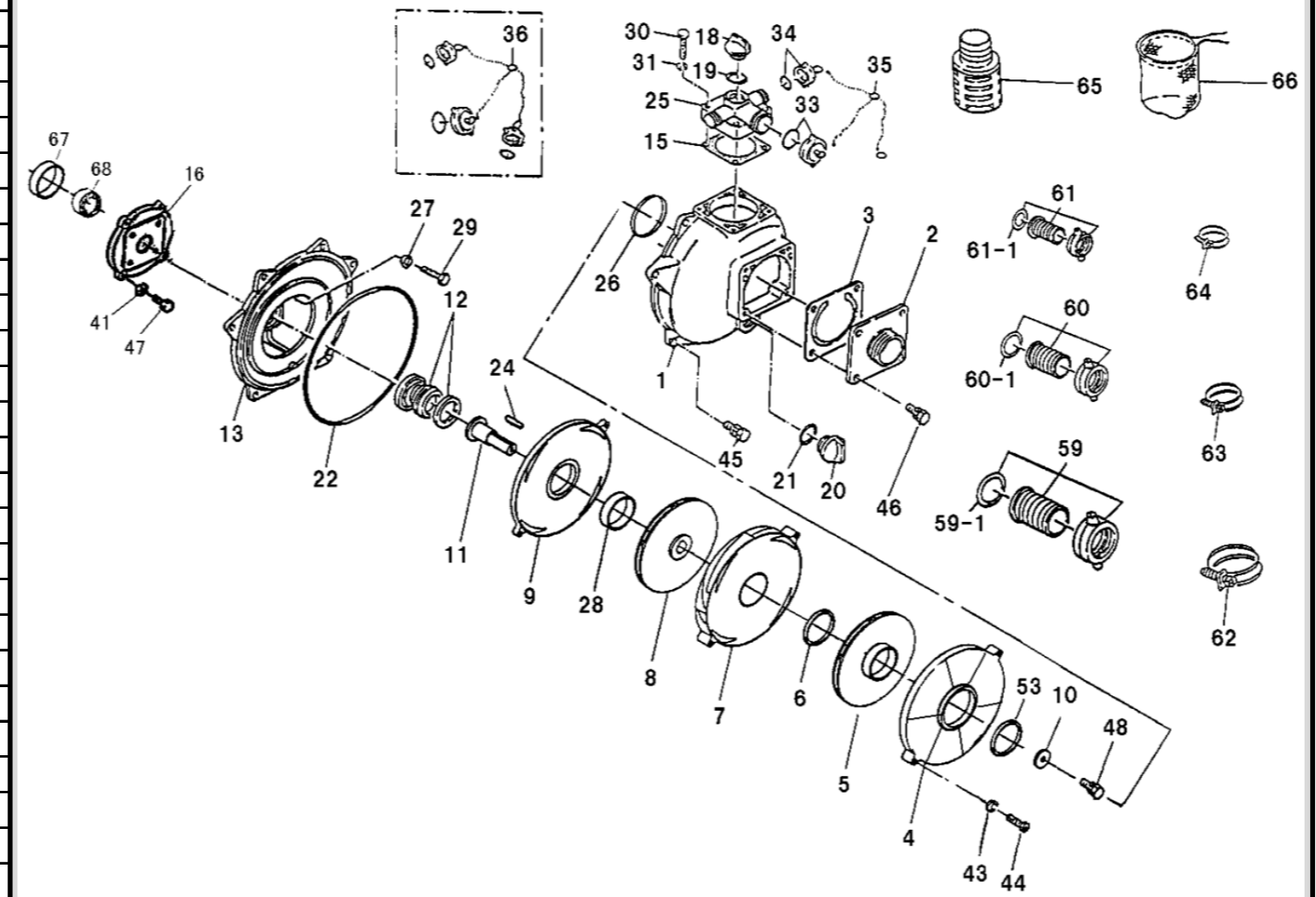

MOTEUR L100

CYLINDER BLOCK			
N°	REF. FOURNISSEUR	DESCRIPTION	QUANTITE
1	114310-01020	BLOCK ASSY, CYLINDER	1
5	114695-01340	GASKET, HEAD 0.5	1
6	114699-01380	O-RING	1
7	114299-01600	PIN, 8X12	2
8	114299-01800	SHIM SET	1
19	114299-01830	COVER,(FO PUMP)	1
20	114250-01841	GASKET	1
21	22312-040080	PARALLEL PIN, M4X8	2
22	23875-020000	PLUG PT1/4,STEEL	1
23	26226-060182	STUD M 6X 18 PLATED	1
24	26226-060222	STUD M 6X 22 PLATED	2
25	26366-060002	NUT M 6	3
26	114699-01410	GASKET, CRANK CASE	1
27	114310-01450	COVER(D, CRANK CASE	1
30	114650-02100	BEARING, MAIN	1
32	114299-35150	PIPE, L.O. INLET	1
33	26106-080352	BOLT M 8X 35 PLATED	16
34	114299-02030	RETAINER, BEARING	1
35	114650-02150	BALL BEARING	1
36	24162-152220	NEEDLE, 152220	1
37 et 38	24423-355008	SEAL, OIL	1
39	26106-080122	BOLT M 8X 12 PLATED	1
40	114650-02200	MAIN BEARING US=0.25	1
41	114650-02210	MAIN BEARING US=0.50	1

CYLINDER BLOCK

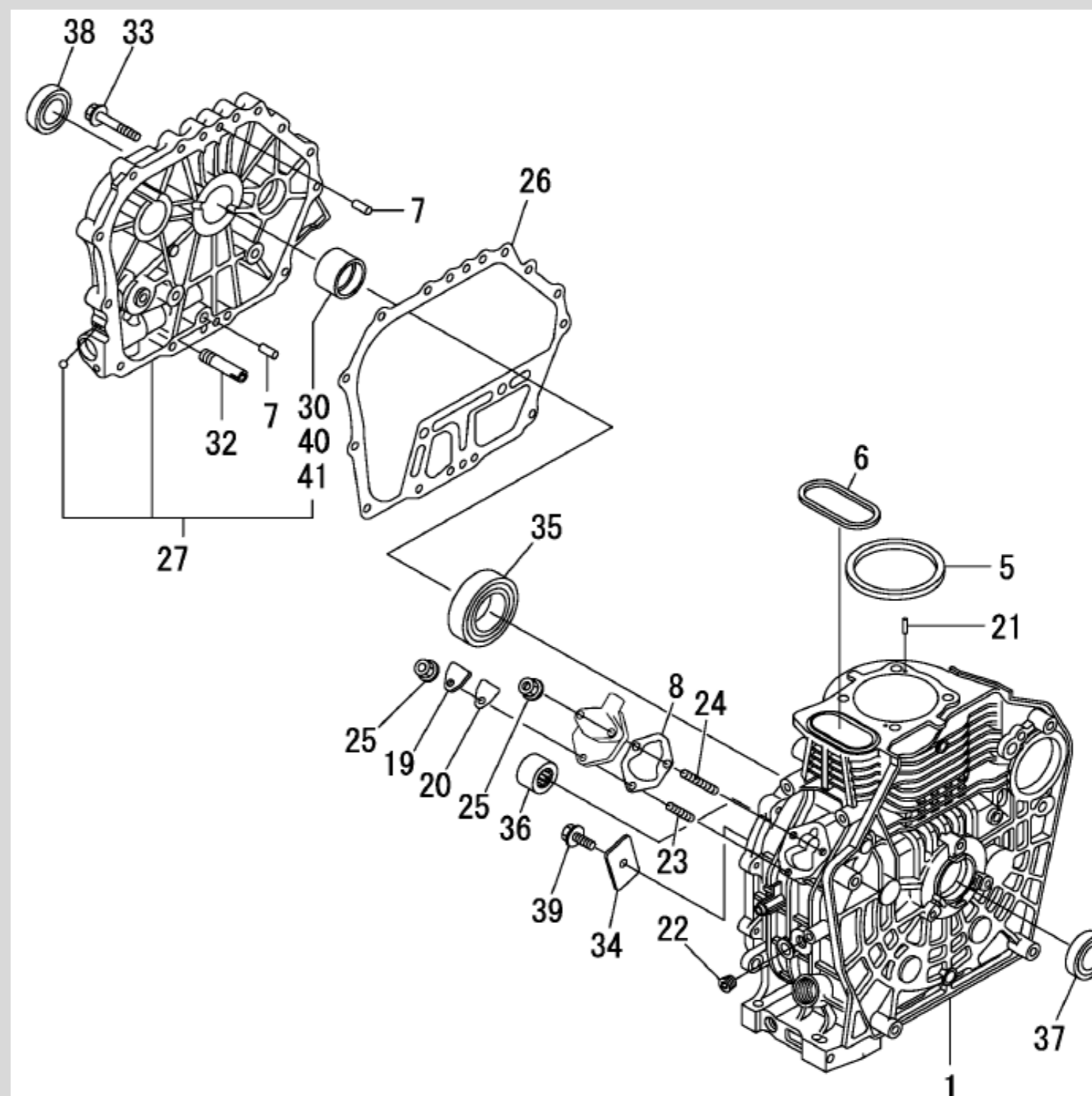

MOTEUR L100

DRAIN PLUG			
N°	REF. FOURNISSEUR	DESCRIPTION	QUANTITE
1	114299-01690	PLUG M16	2
2	114699-01760	CAP ASSY, LO SUPPLY	2
4	114299-01950	O-RING	2
5	22190-160002	WASHER, 16	2

DRAIN PLUG

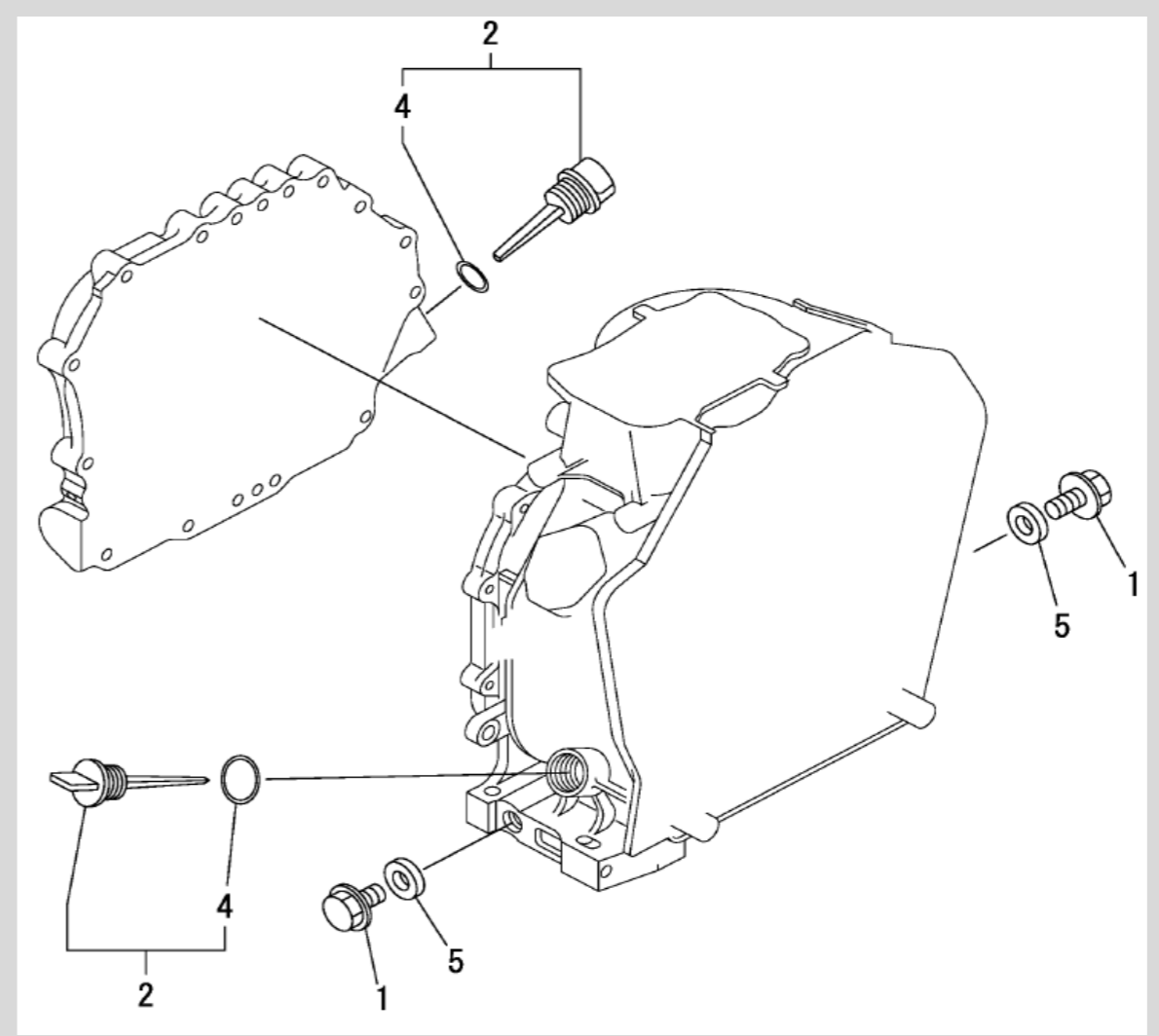

MOTEUR L100

LABEL			
N°	REF. FOURNISSEUR	DESCRIPTION	QUANTITE
2	114220-07100	LABEL, CAUTION	1
3	114299-07100	LABEL, AIR COOLED	1
4	114220-07110	LABEL HOW TO START-E	1
5	114299-07110	LABEL, YANMAR	1
6	114299-07160	LABEL, DIESEL	1
8	114220-07160	LABEL, THAI	1
9	114220-07130	LABEL, HOT SURFACE	1
2	2(G2-14720-2310)	LABEL, YANMAR MARK (B)	1
3	3(G2-14720-2310)	LABEL, DIESEL	1
4	4(G2-14720-2310)	LABEL, OPERATION	1
5	5(G2-14720-2310)	LABEL, EPA EMISSION (SOLELY FOR EXPORT)	1
6	6(G2-14720-2310)	LABEL, HOT SURFACE	1
7	7(G2-14810-2570)	LABEL OPERATION WORMS	1
8	8(G2-14810-2570)	LABEL AIR CLEANER WORMS	1

LABEL

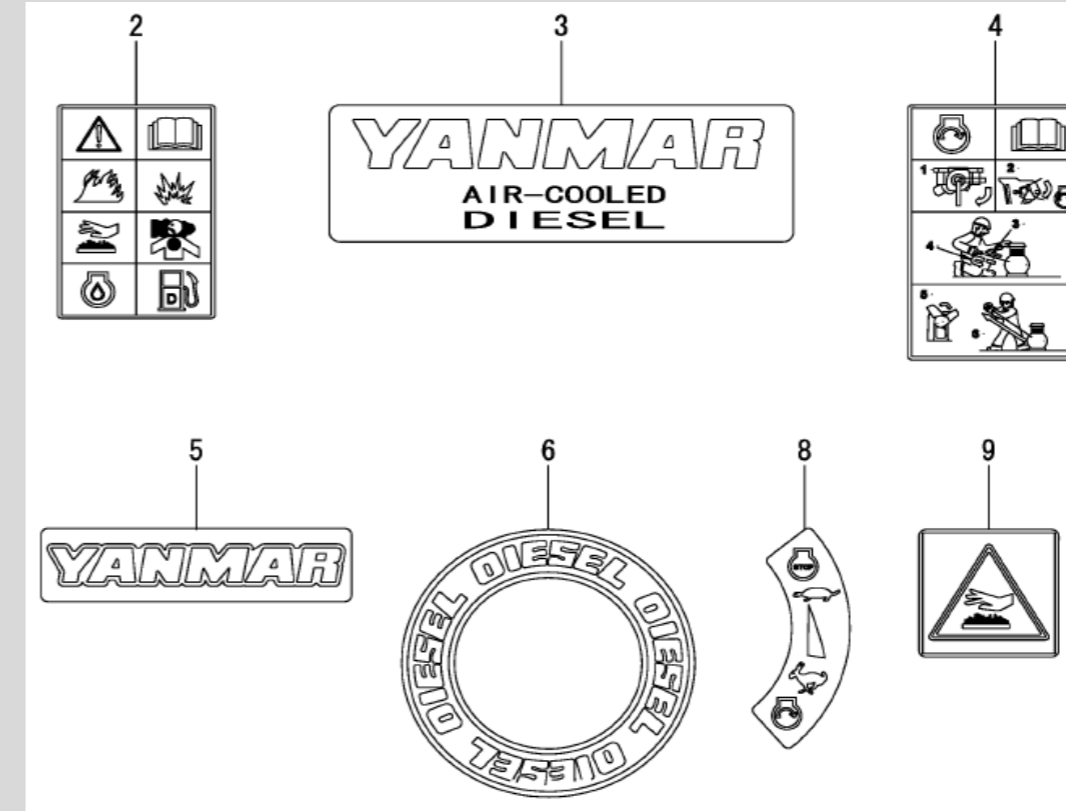

② LABEL, YANMAR MARK (B)



③ LABEL, DIESEL



④ LABEL, OPERATION

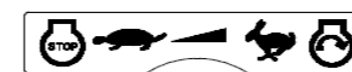

⑤ LABEL, EPA EMISSION (SOLELY FOR EXPORT)

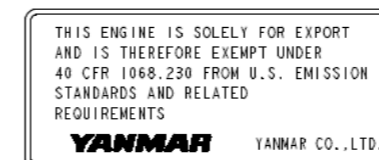

⑥ LABEL, HOT SURFACE (LOOSE PART)



7

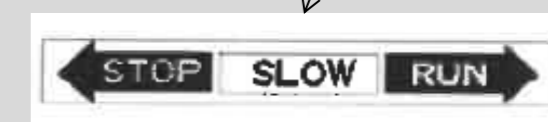

8

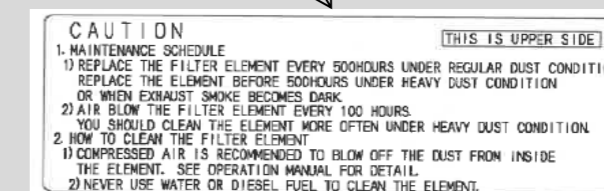

MOTEUR L100

CYLINDER HEAD AND BONNET			
N°	REF. FOURNISSEUR	DESCRIPTION	QUANTITE
1	114310-01200	BOLT, CYL.HEAD A	2
2	114310-01210	BOLT, CYL.HEAD B	2
3	11432C-11020	HEAD ASSY, CYLINDER	1
8	11431C-11100	VALVE, INTAKE	1
9	11431C-11110	VALVE, EXHAUST	1
10	114310-11120	SPRING, VALVE	2
11	114310-11180	RETAINER, SPRING	2
12	114310-11930	COTTER ASSY	2
14	114310-11250	SUPPORT ASSY, ROCKER	1
15	11431C-11260	SUPPORT, ROCKER ARM	1
16	22242-000150	CIRCLIP 15	2
17	11431C-11650	ARM ASSY, INTAKE	1
19	114250-11240	SCREW, VALVE ADJUST.	1
20	26856-060002	LOCK NUT 6	1
21	11431C-11660	ARM ASSY, EXHAUST	1
23	114250-11240	SCREW, VALVE ADJUST.	1
24	26856-060002	LOCK NUT 6	1
25	114650-11341	SEAL, VALVE STEM	2
26	104211-11370	CAP, VALVE	2
27	114240-11450	PROTECTOR, NOZZLE	1
28	114240-11550	SEAT, NOZZLE	1
29	114699-11600	WASHER	2
30	114210-11901	RETAINER, NOZZLE	1
31	22351-040008	SPRING PIN 4X 8	1
32	114310-11290	BOLT, SUPPORT	2
33	26226-060552	STUD M6X 55 PLATED	2
34	26366-060002	NUT M 6	2
35	114310-11310	GASKET, BONNET	1
36	114310-11950	BONNET ASSY, HEAD	1
38	114210-03590	DECOMPRESSION ASSY	1
41	114299-03640	SPRING, DECOMP.	1
43	22312-030160	PARALLEL PIN 3X16	1
47	26106-060652	BOLT M 6X 65 PLATED	3

CYLINDER HEAD AND BONNET

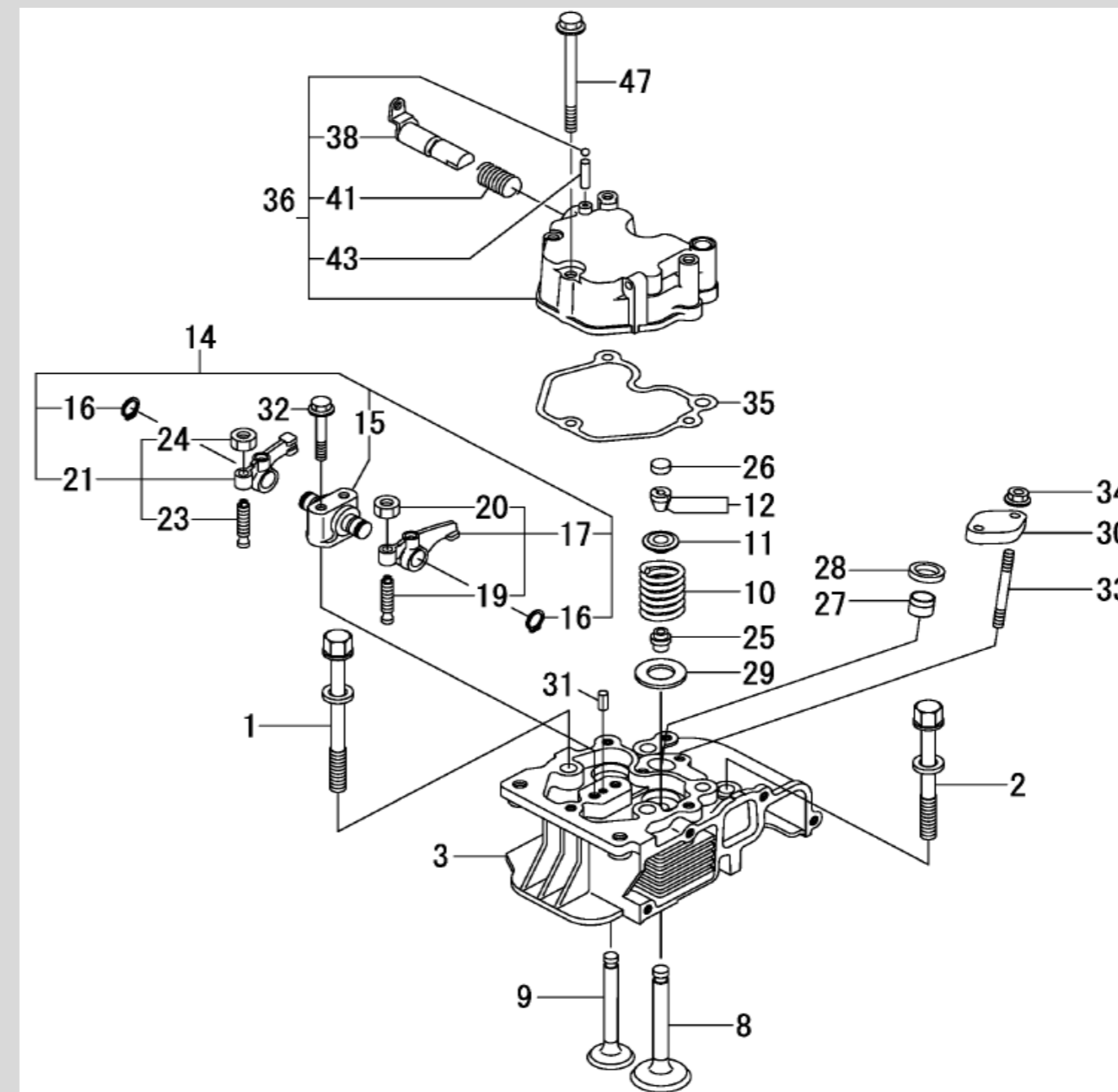

MOTEUR L100

AIR CLEANER			
N°	REF. FOURNISSEUR	DESCRIPTION	QUANTITE
1	114310-12210	GASKET, AIR CLEANER	1
2	114299-12300	U-NUT	3
3	114320-12550	CLEANER ASSY, AIR	1
4	114310-12010	BODY ASSY, AIR CLNR	1
8	114220-12500	COVER ASSY, AIR CLNR	1
11	114210-12560	NUT, WING	1
12	114210-12590	ELEMENT ASSY	1
15	114210-12600	LOCKING KNOB	1
16	26106-060402	BOLT M 6X 40 PLATED	1
17	26226-060352	STUD M 6X 35 PLATED	3

AIR CLEANER

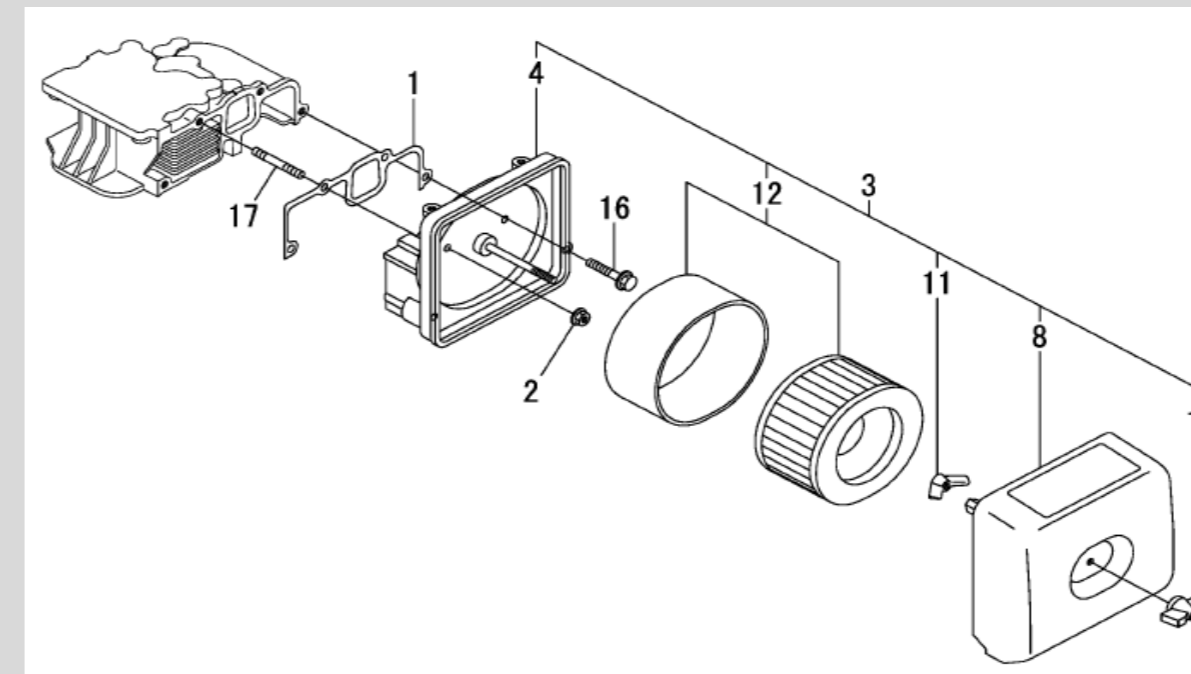

MOTEUR L100

EXHAUST MUFFLER			
N°	REF. FOURNISSEUR	DESCRIPTION	QUANTITE
1	114310-13200	GASKET, MUFFLER	1
2	11431C-13550	MUFFLER ASSY	1
3	11431C-13560	MUFFLER	1
4	11431C-13700	COVER, MUFFLER A	1
5	11431C-13710	COVER, MUFFLER B	2
6	11431C-13720	BOLT, M6X6 FLANGE	10
7	26106-080202	BOLT M 8X 20 PLATED	2
8	26216-080182	STUD M 8X 18 PLATED	2
9	26366-080002	NUT M 8	2

EXHAUST MUFFLER

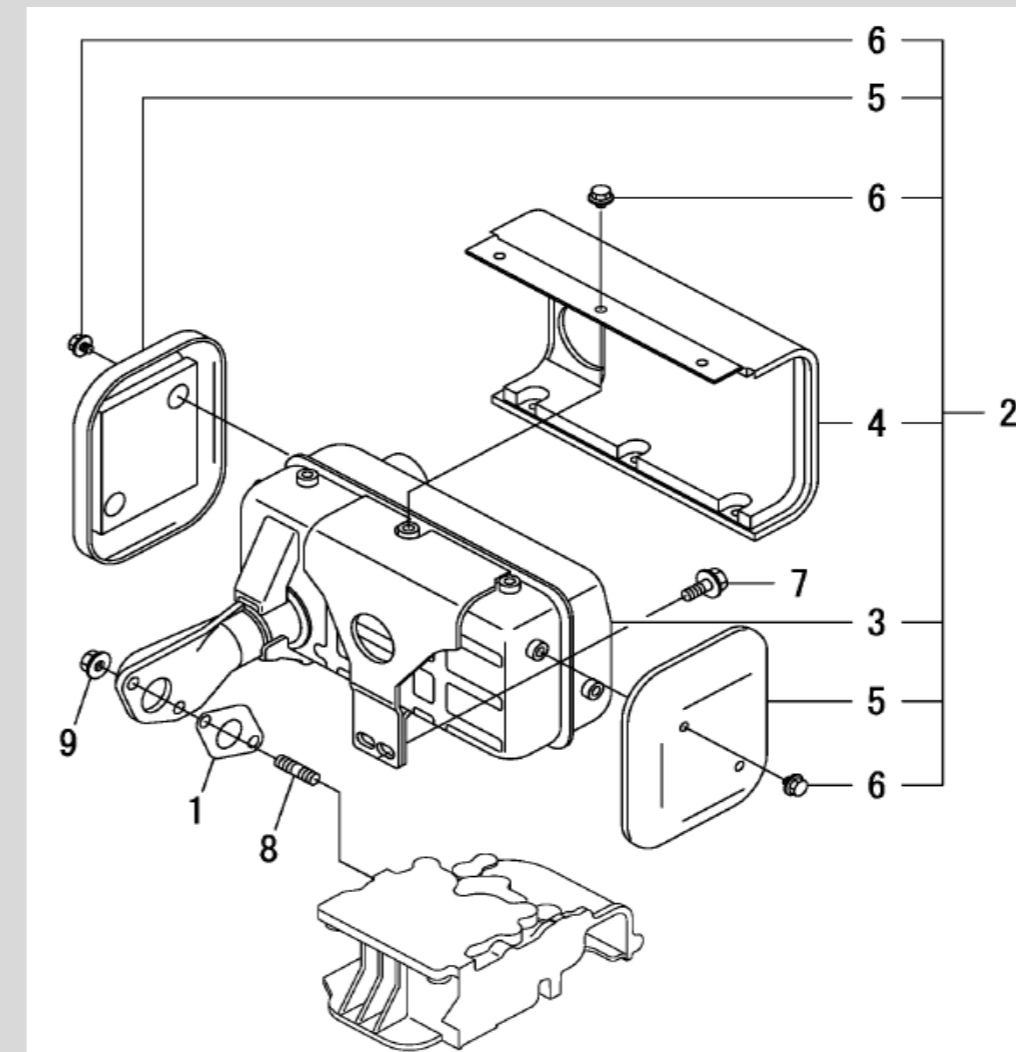

MOTEUR L100

CAMSHAFT			
N°	REF. FOURNISSEUR	DESCRIPTION	QUANTITE
1	71432C-14010	CAMSHAFT ASSY	1
6	114310-14200	TAPPET	2
7	114210-14300	TAPPET ASSY, ROLLER	1
12	114310-14400	ROD ASSY, PUSH	2

CAMSHAFT

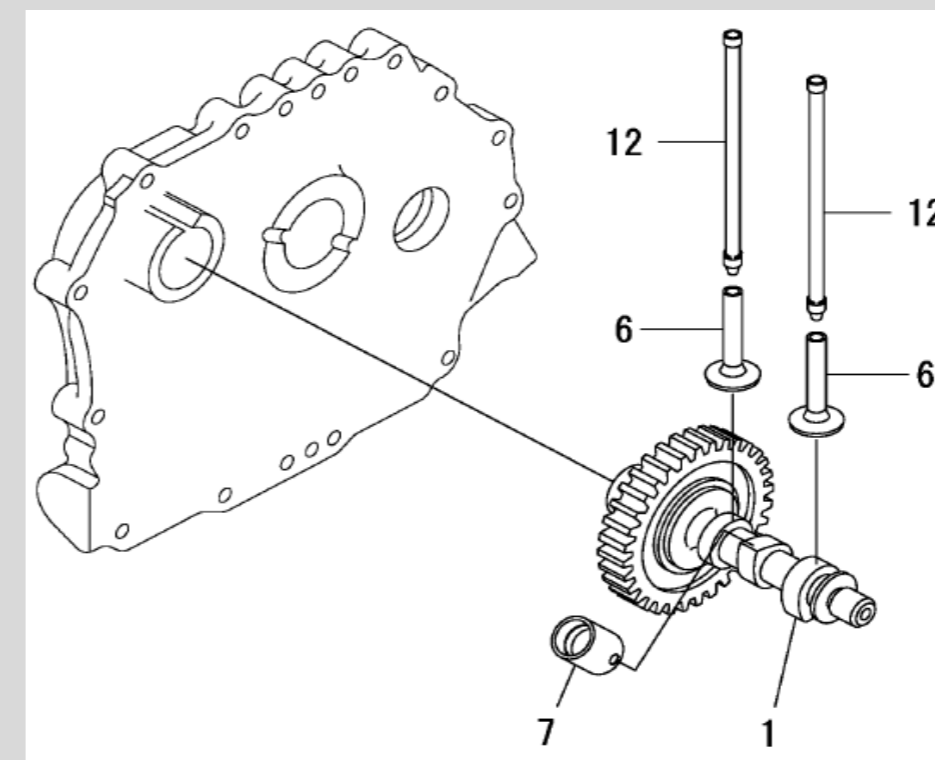

MOTEUR L100

CRANKSHAFT			
N°	REF. FOURNISSEUR	DESCRIPTION	QUANTITE
1	11431C-21840	CRANKSHAFT ASSY,E-DG	1

CRANKSHAFT

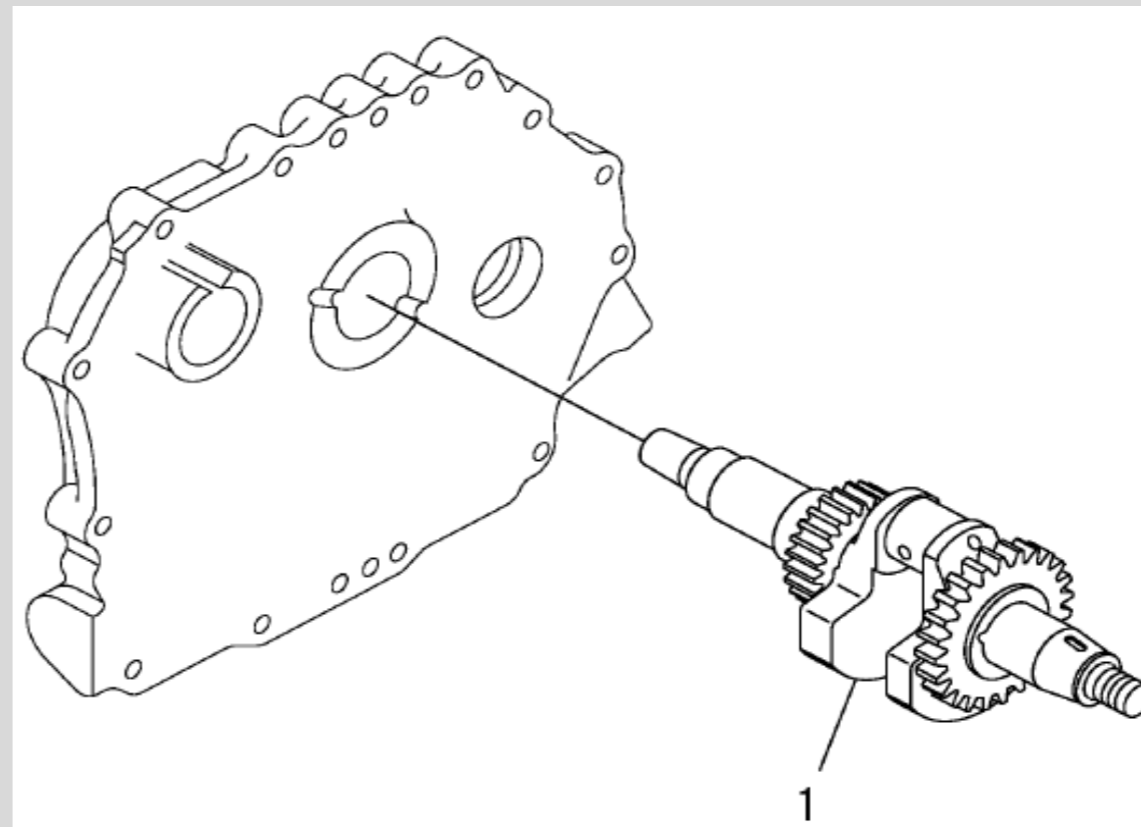

MOTEUR L100

FLYWHEEL			
N°	REF. FOURNISSEUR	DESCRIPTION	QUANTITE
1	114699-21220	NUT	1
2	114699-21550	WASHER, FLYWHEEL	1
3	114699-21600	FLYWHEEL ASSY, DE	1
6	114699-21630	RING, GEAR	1
7	22512-050140	KEY, 5X14	1

FLYWHEEL

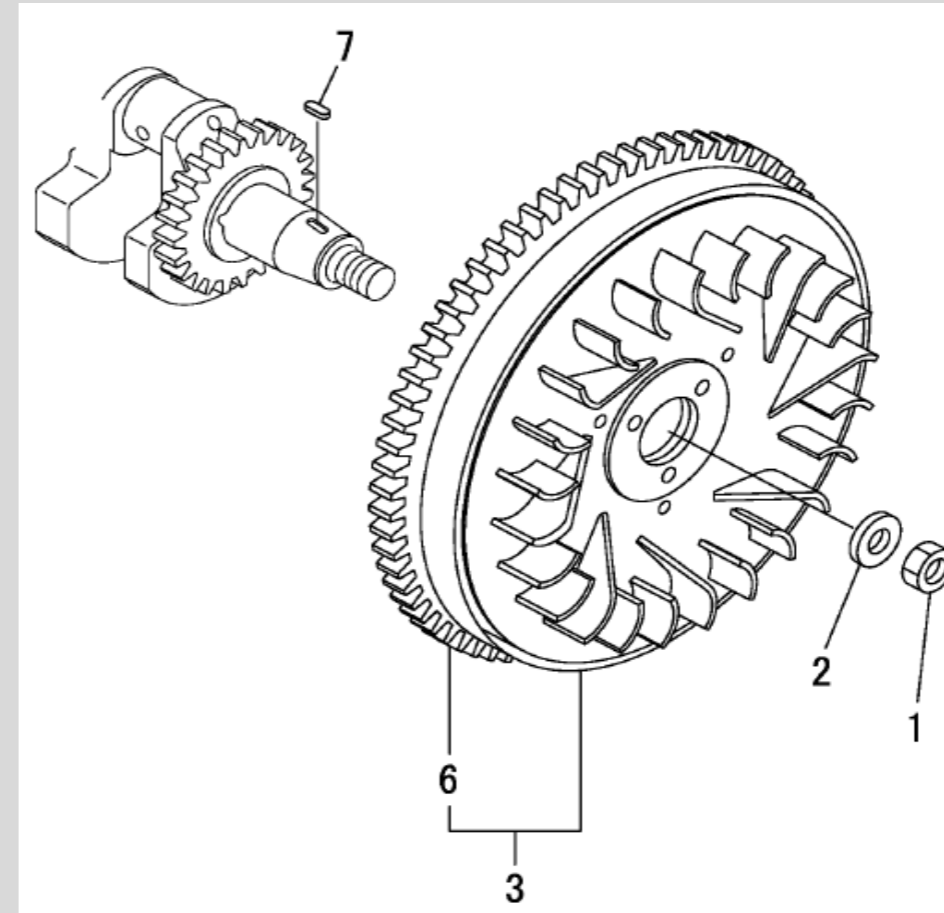

MOTEUR L100

PISTON & CONNECTING ROD			
N°	REF. FOURNISSEUR	DESCRIPTION	QUANTITE
1	714320-22720	PISTON W/RINGS (D)	1
3	714310-22500	RING SET, PISTON	1
9	114699-22300	PIN, PISTON	1
10	114310-22500	SEEGER RING, J23	2
11	71431C-23010	ROD ASSY, CONNECTING	1
14	124060-23100	BUSH, PISTON PIN	1
15	114310-23200	BOLT, CONNECTING ROD	2
16	714650-23600	BEARING, CRANKPIN	1
18	714320-22620	PISTON W/RING .25OS	1
20	714310-22540	RING SET O.S=0.25	1
24	714320-22580	PISTON W/RING .50OS	1
26	714310-22550	RING SET O.S=0.50	1
30	714650-23610	BEARING,PIN(U.S=0.25	1
32	714650-23620	BEARING,PIN(U.S=0.50	1

PISTON & CONNECTING ROD

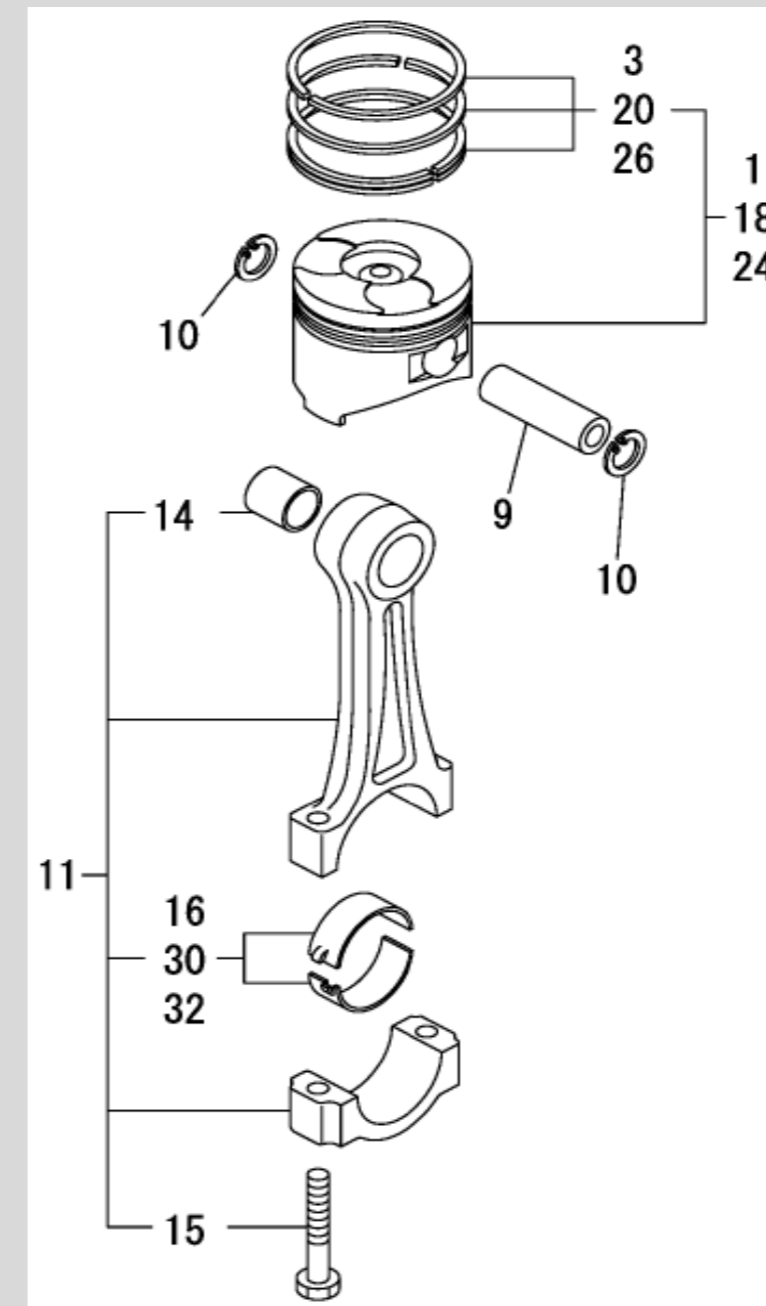

MOTEUR L100

BALANCER SHAFT			
N°	REF. FOURNISSEUR	DESCRIPTION	QUANTITE
1	714310-28510	SHAFT ASSY, BALANCER	1
6	24101-063040	BALL BEARING	2

BALANCER SHAFT

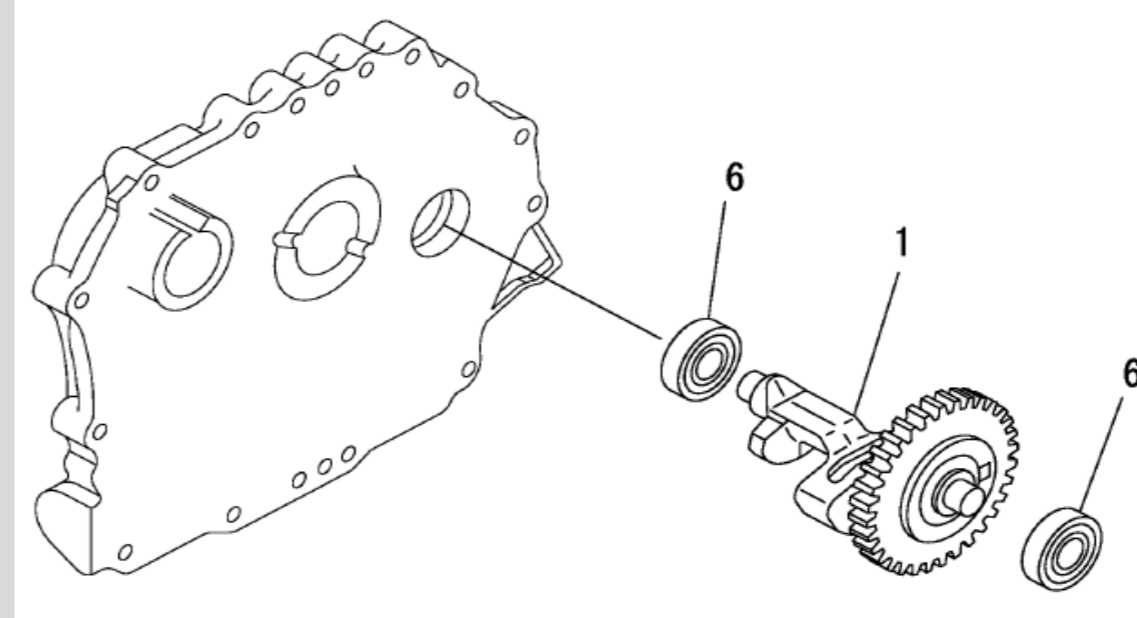

MOTEUR L100

LUB.OIL PUMP AND GOVERNOR			
1	114650-32010	PUMP ASSY, LUB.OIL	1
7	114299-32070	COVER, LUB. OIL PUMP	1
8	114299-32570	O-RING, COVER	1
9	22312-030160	PARALLEL PIN 3X16	1
10	26106-060122	BOLT M 6X 12 PLATED	3
11	114299-35110	FILTER CMP, LUB.OIL	1
13	24341-000224	O-RING 1A S-22.4	1
14	26106-060162	BOLT M 6X 16 PLATED	1
15	114311-61500	LEVER ASSY, GOVERNOR	1
24	22322-030200	TAPER PIN 3X20	1
26	714210-61701	GOVERNOR ASSY	1
27	114210-61290	WEIGHT ASSY,GOVERNOR	1
32	114770-61520	BEARING	2
33	114299-61600	SEAL, OIL	1
34	114770-61610	WASHER, THRUST	1
35	114299-61190	WASHER, GOVERNOR	1
36	114210-66550	BRACKET CMP,REGULATOR	1
37	114210-66070	HANDLE, REGULATOR	1
38	183250-66070	SHAFT, HANDLE	1
39	114210-66400	BRACKET, HANDLE	1
40	114250-66440	BOLT, ADJUSTING	1
41	104200-66820	SPRING, HANDLE	1
42	104200-66831	PLATE, FRICTION	2
43	104200-66850	WASHER, B	1
44	26696-100002	NUT, 10	1
45	26757-060002	NUT, 6	1
46	26106-060142	BOLT, 6 X 14	1
47	26106-060452	BOLT, 6 X 45	1
48	114770-66010	SPRING, REGULATOR	1
49	114299-66200	SPRING, RETURN	1
50	114211-66600	LIMITER ASSY, FUEL	1
55	26776-100002	NUT, 10	1
56	114780-61090	TIN	2
57	22451-060000	WIRE, 0.6	2

LUB.OIL PUMP AND GOVERNOR

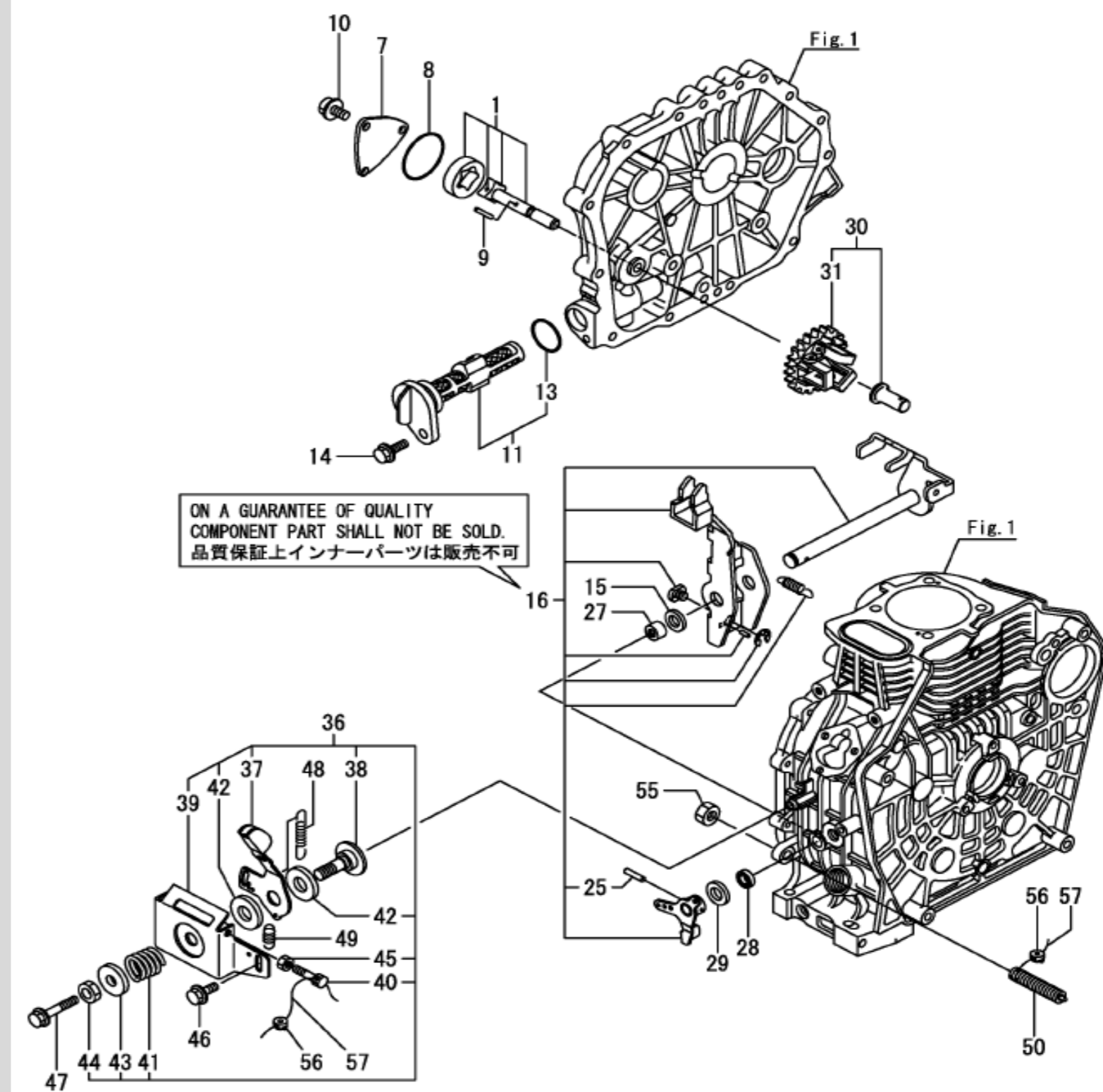

MOTEUR L100

OIL PRESSURE SWITCH			
N°	REF. FOURNISSEUR	DESCRIPTION	QUANTITE
1	183250-39450	SWITCH, OIL PRESSURE	1

OIL PRESSURE SWITCH

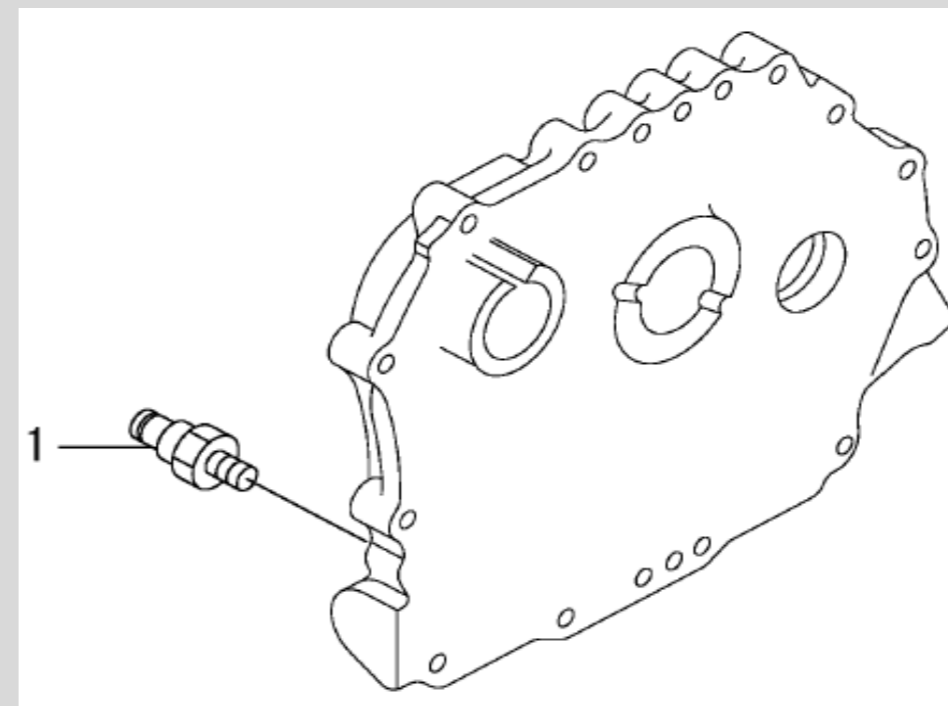

MOTEUR L100

COVER			
N°	REF. FOURNISSEUR	DESCRIPTION	QUANTITE
1	11432C-45200	TOP COVER ASSY	1
2	114220-07120	LABEL, DECOMPRESSION	1
3	11431C-45300	COVER, TOP(BLACK)(13)	1
4	11431C-45310	DAMPER	1
5	114350-45340	COLLAR	4
6	183720-55210	GROMMET	4
7	114299-45220	GROMMET, TANK	1
8	11431C-45260	COVER B, SIDE (13)	1
9	11431C-45270	COVER A, SIDE (13)	1
10	114399-45320	RUBBER, SEAL	1
11	114399-45340	COLLAR, CYL.COVER	1
12	114310-45350	SPACER, TOP COVER	1
13	114310-45360	STUD BOLT, TOP COVER	1
14	26106-060082	BOLT M 6X 8 PLATED	4
15	26106-060202	BOLT M 6X 20 PLATED	4
16	26366-060002	NUT M 6	1

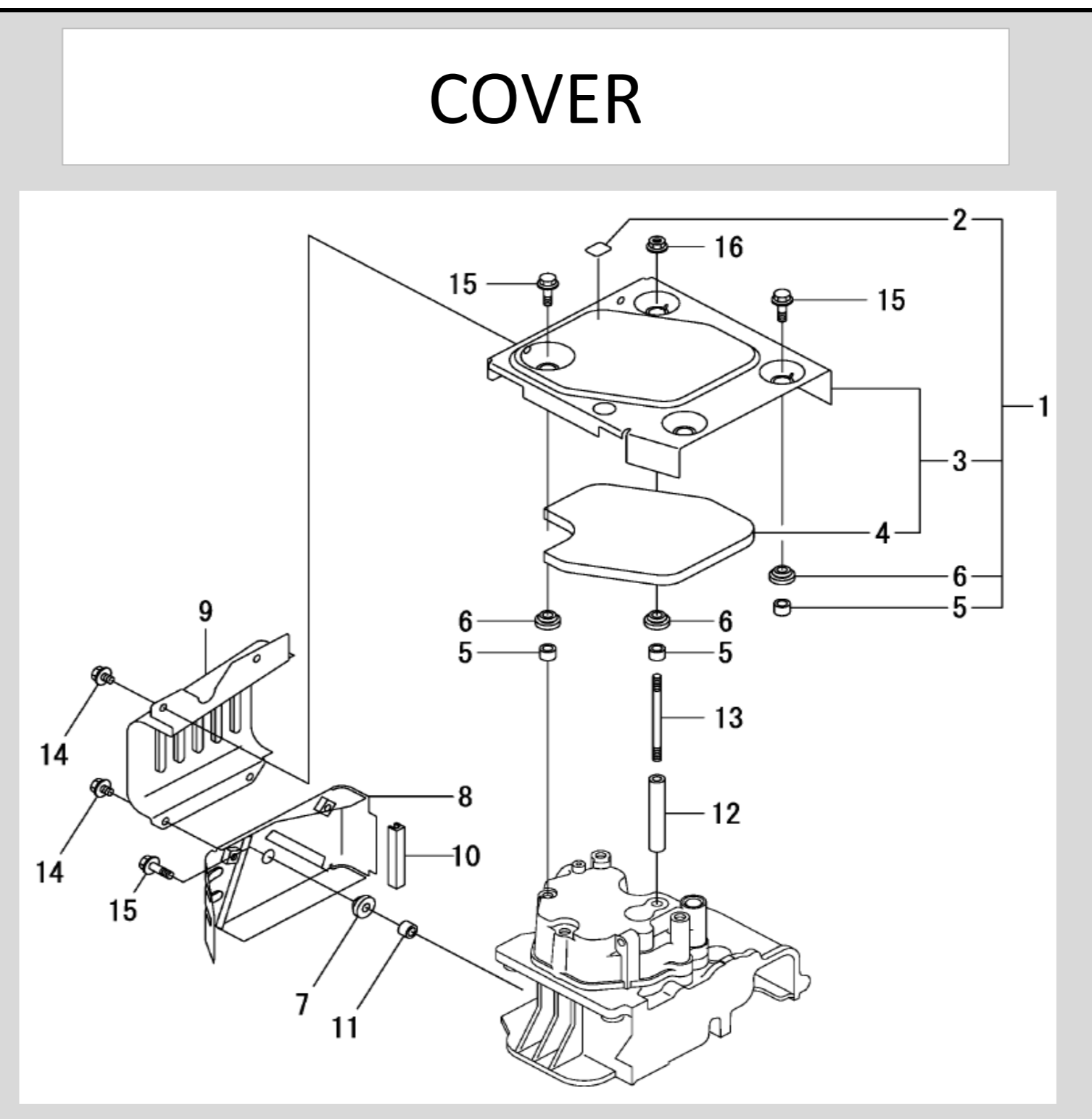

MOTEUR L100

COOLING FAN CASE			
N°	REF. FOURNISSEUR	DESCRIPTION	QUANTITE
1	11431C-45100	FAN CASE (GRAY)(2K)	1
2	114299-45301	RUBBER, CUSHION	4
3	114299-45310	COLLAR, FAN CASE	4
4	114699-45331	SEAL, FAN CASE	1
5	114299-45350	BOLT, FAN CASE	4

COOLING FAN CASE

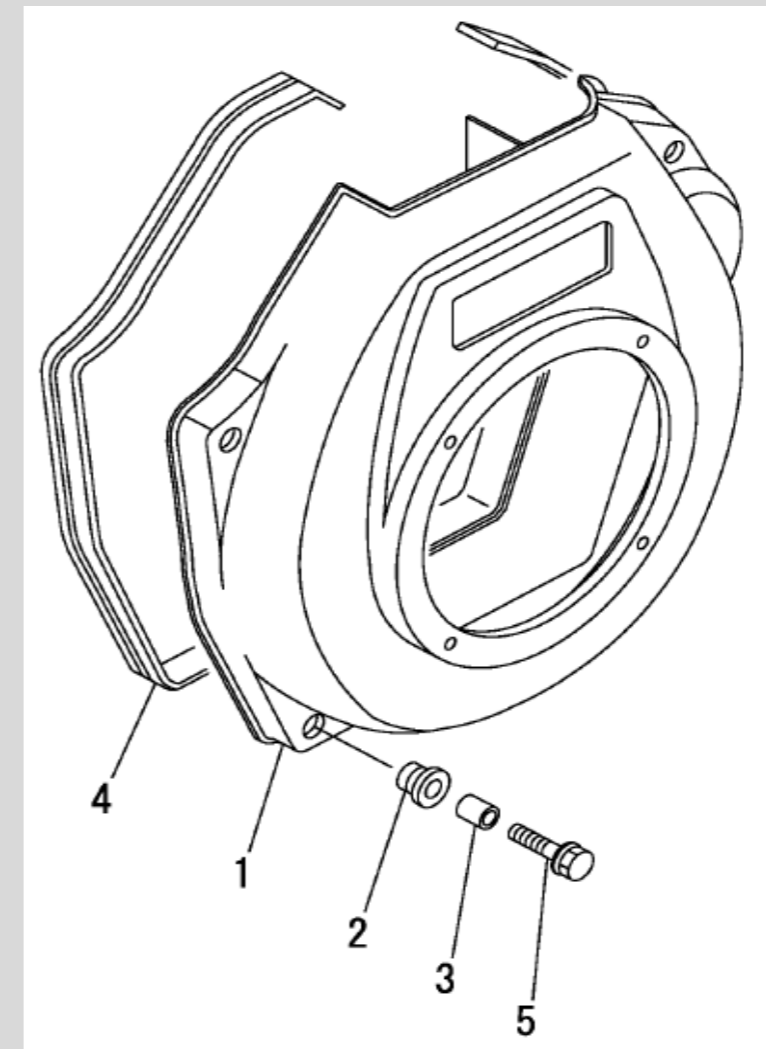

MOTEUR L100

F.I.PUMP & F.I.VALVE			
N°	REF. FOURNISSEUR	DESCRIPTION	QUANTITE
1	714339-51310	F.I.PUMP ASSY	1
2	105546-51020	GASKET, PUMP BODY	1
3	114250-51080	PLATE	1
4	114339-51200	BODY ASSY, PUMP	1
10	22351-020006	PIN, 2.0A X 6	2
11	114250-51160	SPRING, PLUNGER	1
12	114650-51300	VALVE ASSY, DELIVERY	1
15	105546-51330	SPRING, DELIVERY	1
16	114250-51340	HOLDER, DELIVERY	1
17	124550-51350	GASKET, DELIVERY	2
18	114250-51600	LEVER, CONTROL	1
19	114250-51640	SEAT A, SPRING	1
20	114250-51650	SEAT B, SPRING	1
21	22351-030008	PIN, 3.0A X 8	1
22	714339-53200	FUEL INJECTOR	1
23	114250-53080	NUT, CASE	1
24	114339-53100	HOLDER ASSY, NOZZLE	1
28	22351-025005	PIN, 2.5A X 6	1
29	114250-53120	SPRING, NOZZLE	1
30	114250-53130	SEAT, SPRING	1
31	114250-53140	PLATE, STOP	1
32	114339-53200	NOZZLE ASSY	1
35	114250-53210	PIN	2
36	114250-53400	SHIM SET	1
48	114110-76901	VALVE ASSY, F/O CUT	1
49	114299-83020	GASKET, 10X1.2	1
50	114310-59800	PIPE ASSY, INJECTION	1
56	114699-59850	SUPPORT, PIPE	1

F.I.PUMP & F.I.VALVE

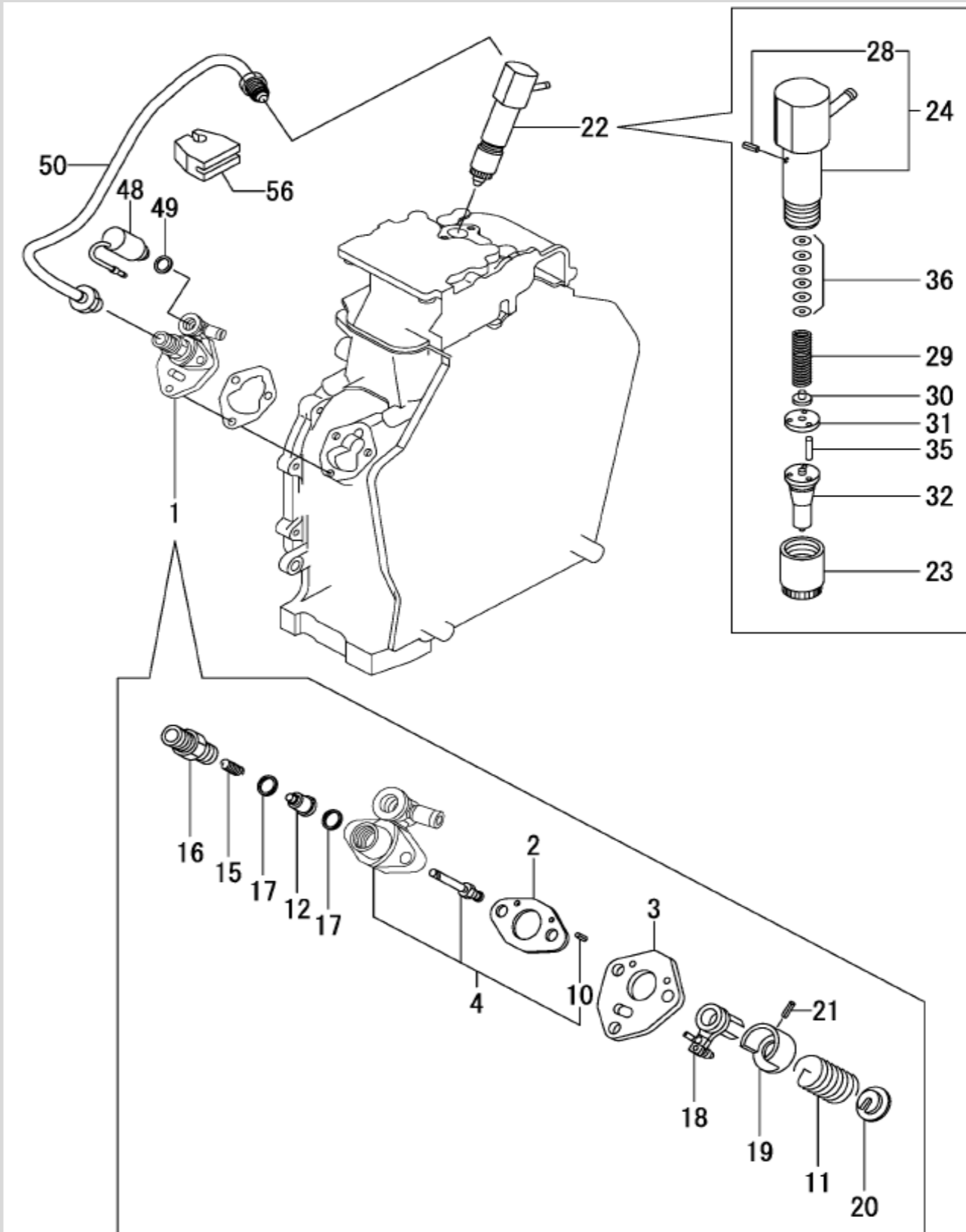

MOTEUR L100

FUEL TANK & FUEL PIPE			
N°	REF. FOURNISSEUR	DESCRIPTION	QUANTITE
1	114250-55121	FILTER ASSY, FUEL	1
2	114250-55130	GASKET	1
3	114210-55210	STAY A, FUEL TANK	1
4	114310-55230	STAY B, FUEL TANK	1
5	114250-55301	COCK ASSY, FUEL	1
6	24341-000150	O-RING 1A S-15.0	1
7	11431C-55710	TANK, FUEL(BLACK)(13)	1
9	114299-55080	PLUG, DRAIN	1
10	23414-080000	GASKET 8, ROUND	1
11	114299-55040	CAP ASSY, FUEL TANK	1
12	114299-55100	FILTER, FUEL OIL	1
13	114250-55201	DAMPER, FUEL TANK	4
14	114210-55810	BOLT, LIFTING	1
15	22117-080000	WASHER 8	1
16	26106-060162	BOLT M 6X 16 PLATED	2
17	26106-080452	BOLT M 8X 45 PLATED	1
18	26366-060002	NUT M 6	2
19	114780-59010	PIPE ASSY, FUEL OIL	1
20	114780-59060	PIPE, FUEL OIL	1
21	23080-014000	CLAMP 14	2
22	114339-59300	PIPE ASSY, RETURN	1
23	124722-59050	CLAMP, HOSE 9	1
24	114310-59060	PIPE, FUEL RETURN	1
25	124066-59100	CLIP, HOSE	1
26	114310-59310	HOSE, PROTECT	1
27	121750-59890	CLAMP 140	1

FUEL TANK AND FUEL PIPE

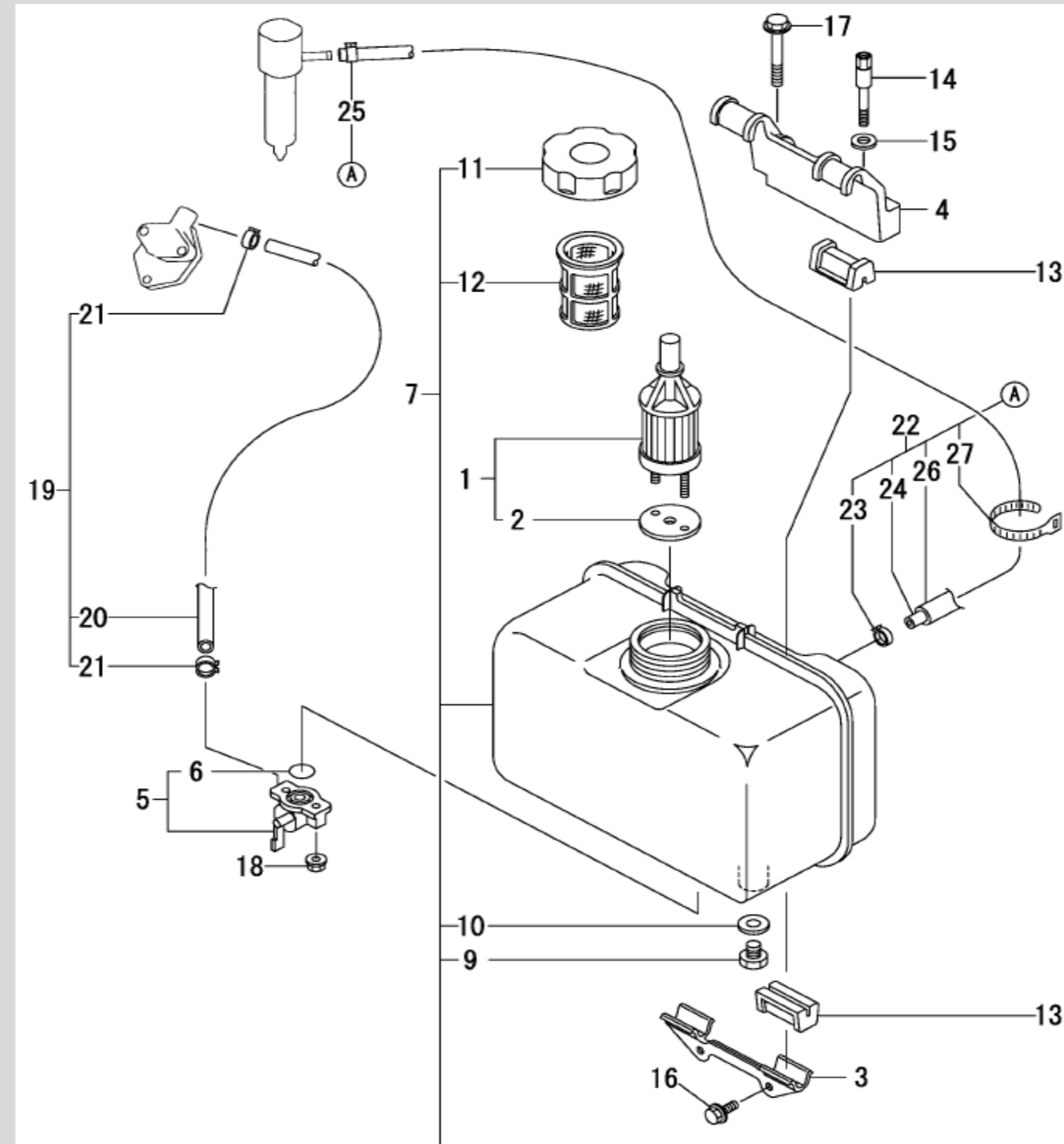

MOTEUR L100

RECOIL STARTER			
N°	REF. FOURNISSEUR	DESCRIPTION	QUANTITE
2	114699-76251	RECOIL ASSY	1
3	114699-76510	CASE, STARTER	1
4	114699-76521	REEL, RECOIL	1
6	114699-76531	RATCHET	2
7	114399-76540	SPRING, SPIRAL	1
8	114699-76551	GUIDE, RATCHET	1
9	114699-76560	SPRING, FRICTION	1
10	114399-76620	KNOB, STARTER	1
11	114699-76630	ROPE, STARTER	1
12	114699-76650	SPRING, RETURN	1
13	114699-76660	RETAINING RING	1
14	114699-76670	WASHER	1
15	114699-76680	WASHER IN NYLON	1
16	114699-76592	PULLEY, STARTER	1
17	26106-060082	BOLT M 6X 8 PLATED	4
18	26106-060122	BOLT M 6X 12 PLATED	3

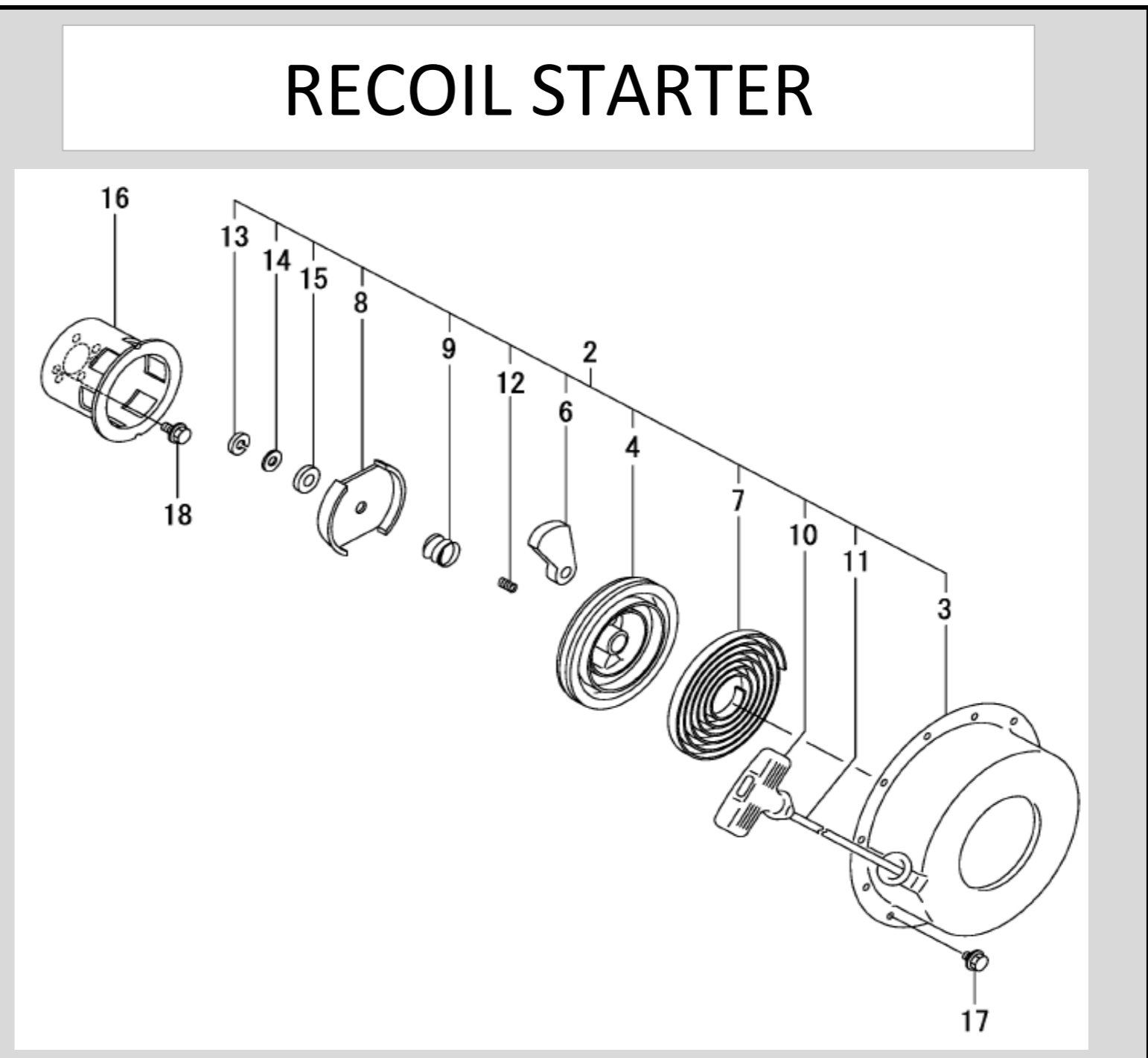

MOTEUR L100

STARTING MOTOR			
N°	REF. FOURNISSEUR	DESCRIPTION	QUANTITE
1	114362-77011	MOTOR ASSY, STARTER	1
2	114381-77110	ARMATURE	1
3	X2114811000	WASHER KIT, THRUST	1
4	X2114715500	STOPPER SET, PINION	1
5	114381-77130	COIL ASSY, FIELD	1
6	114381-77140	COVER, REAR	1
7	114371-77160	HOLDER ASSY, BRUSH	1
8	114371-79040	BRUSH (-)	2
9	114371-79050	BRUSH (+)	1
10	114371-79060	SPRING, BRUSH	4
11	X211485016	PINION ASSY	1
12	114381-77151	HOUSING ASSY, GEAR	1
13	114371-77170	COVER KIT, DUST	1
14	114371-77180	SHIFT LEVER KIT	1
15	124298-77020	SWITCH, MAGNET	1
16	124195-77770	THROUGH BOLT	2
17	114371-79070	BOLT M 6X 37	2
18	X2114274200	COVER, TERMINAL	1
19	26106-100302	BOLT, 10 X 30	2
20	26716-080002	NUT, 8	1

STARTING MOTOR

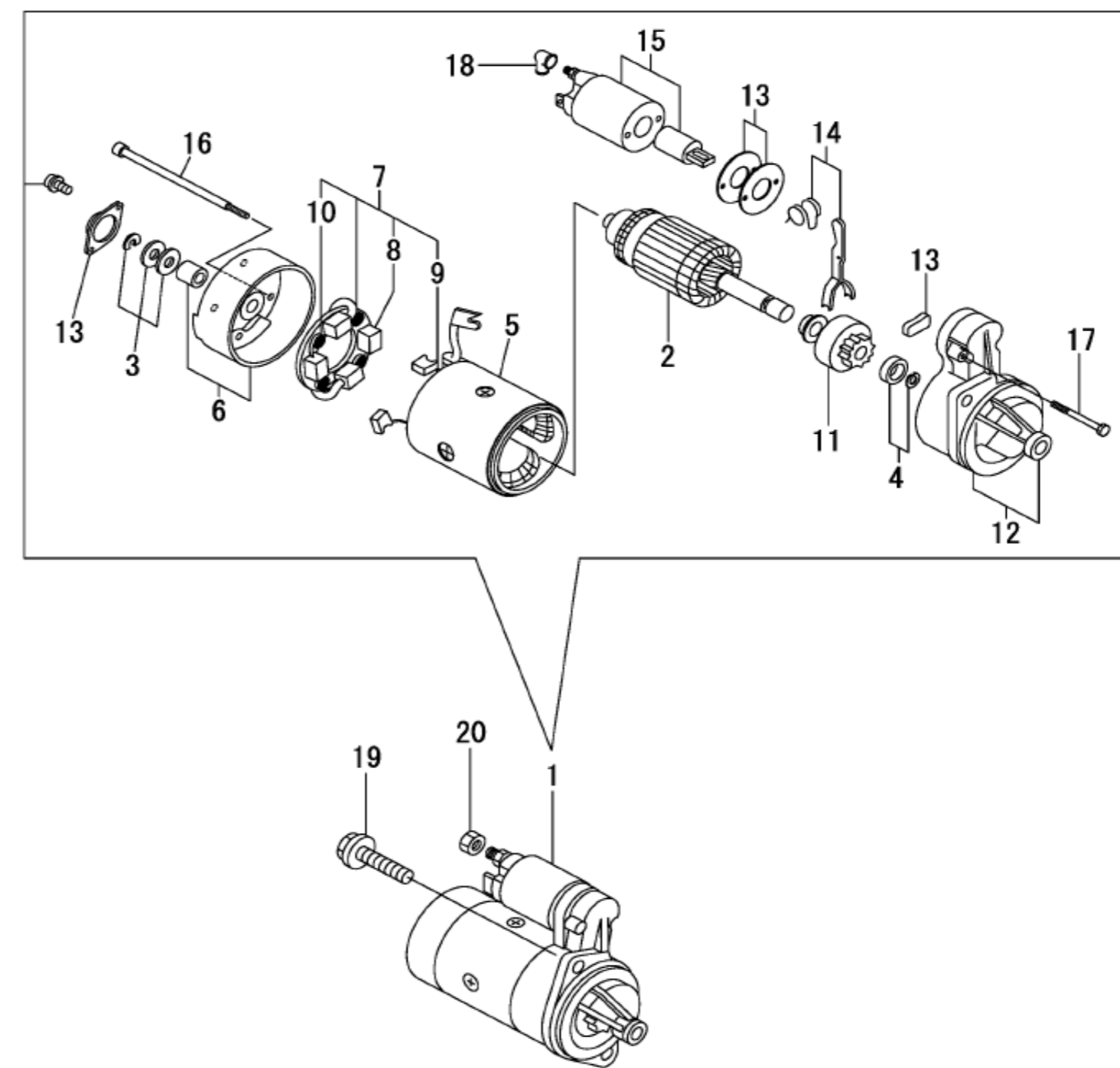

MOTEUR L100

ELECTRICAL EQUIPMENT			
N°	REF. FOURNISSEUR	DESCRIPTION	QUANTITE
1	114399-77550	REG. & HARNESS ASSY	1
3	114399-77400	BRACKET, HARNESS	1
4	114399-77540	HARNESS, WIRE	1
5	114399-78000	FUSE(20A)	1
6	114399-77710	REGULATOR	1
7	26023-040102	SCREW, M4X10	2
8	26106-060122	BOLT M 6X 12 PLATED	2
9	26106-060202	BOLT M 6X 20 PLATED	2

ELECTRICAL EQUIPMENT

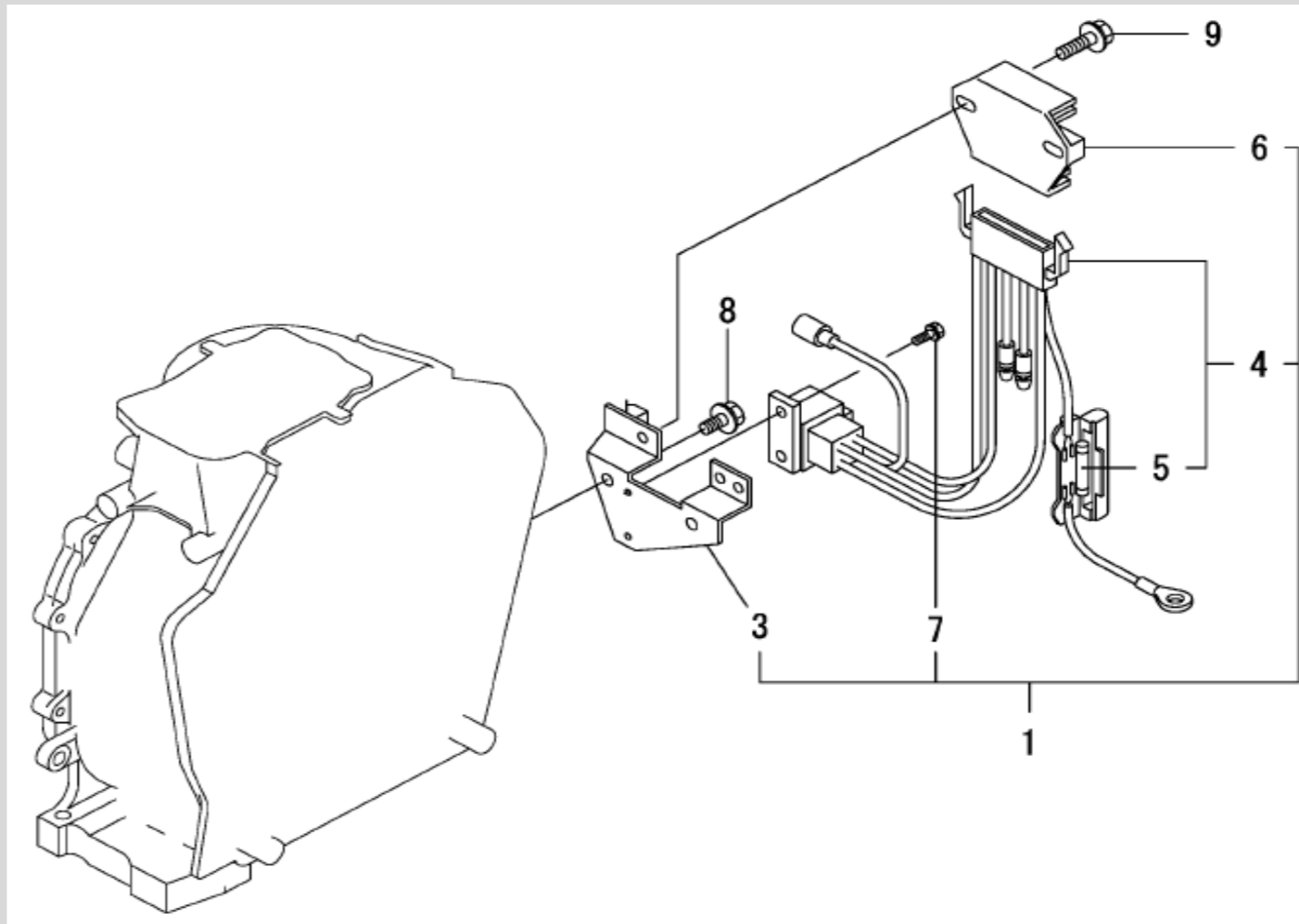

MOTEUR L100

DYNAMO			
N°	REF. FOURNISSEUR	DESCRIPTION	QUANTITE
1	114399-78260	DYNAMO ASSY	1
2	114399-78730	STATOR ASSY	1
3	114399-78740	WHEEL, DYNAMO	1
4	160710-78710	CLAMP, CORD	1
5	26106-060122	BOLT M 6X 12 PLATED	1
6	26106-060202	BOLT M 6X 20 PLATED	3
7	26577-060142	SCREW M 6X 14	3

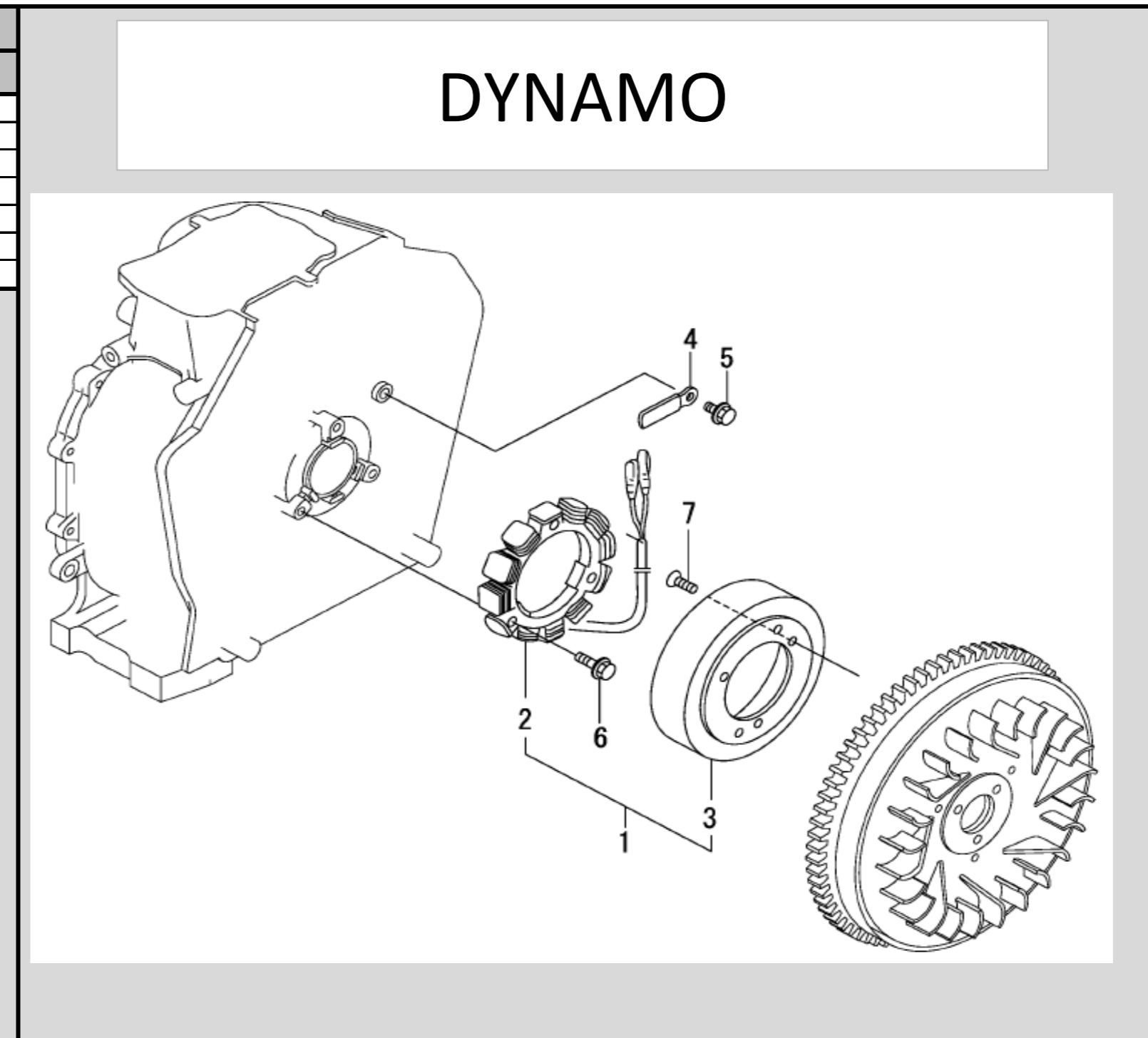

MOTEUR L100

ACCESSORIES			
N°	REF. FOURNISSEUR	DESCRIPTION	QUANTITE
1	114351-77520	JOINT	1

ACCESSORIES

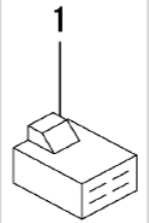

MOTEUR L100

TOOL AND GASKET SET			
N°	REF. FOURNISSEUR	DESCRIPTION	QUANTITE
1	114299-92590	TOOL ASSY	1
2	114299-92600	TOOL BAG	1
3	114299-92710	WRENCH	1
4	114299-92720	WRENCH	1
5	114299-92730	DRIVER	1
6	114299-92740	FITTING, FUEL	1
7	114320-92600	GASKET SET	1
8	114695-01331	GASKET ASSY, CYL. HEAD	1
14	114699-01380	O-RING	2
15	114699-01410	GASKET, CRANK CASE	1
16	114250-01841	GASKET	1
17	114299-01950	O-RING	1
18	114310-11310	GASKET, BONNET	1
19	114650-11341	SEAL, VALVE STEM	2
20	114771-11461	GASKET, NOZZLE	1
21	114310-12210	GASKET, AIR CLEANER	1
22	114699-12210	GASKET, CLEANER	2
23	114310-13200	GASKET, MUFFLER	1
24	183671-13211	GASKET, PIPE	1
25	114399-21980	GASKET	1
26	114299-32570	O-RING, COVER	1
27	160393-55050	GASKET, TANK CAP	4
28	129100-77510	GASKET, AIR HEATER	3
29	22190-160002	WASHER, 16	2
30	23414-080000	GASKET 8, ROUND	1
31	23414-120000	GASKET 12, ROUND	1
32	24311-000400	O-RING 1A P-40.0	1
33	24341-000150	O-RING 1A S-15.0	2
34	24341-000224	O-RING 1A S-22.4	1

TOOL AND GASKET SET

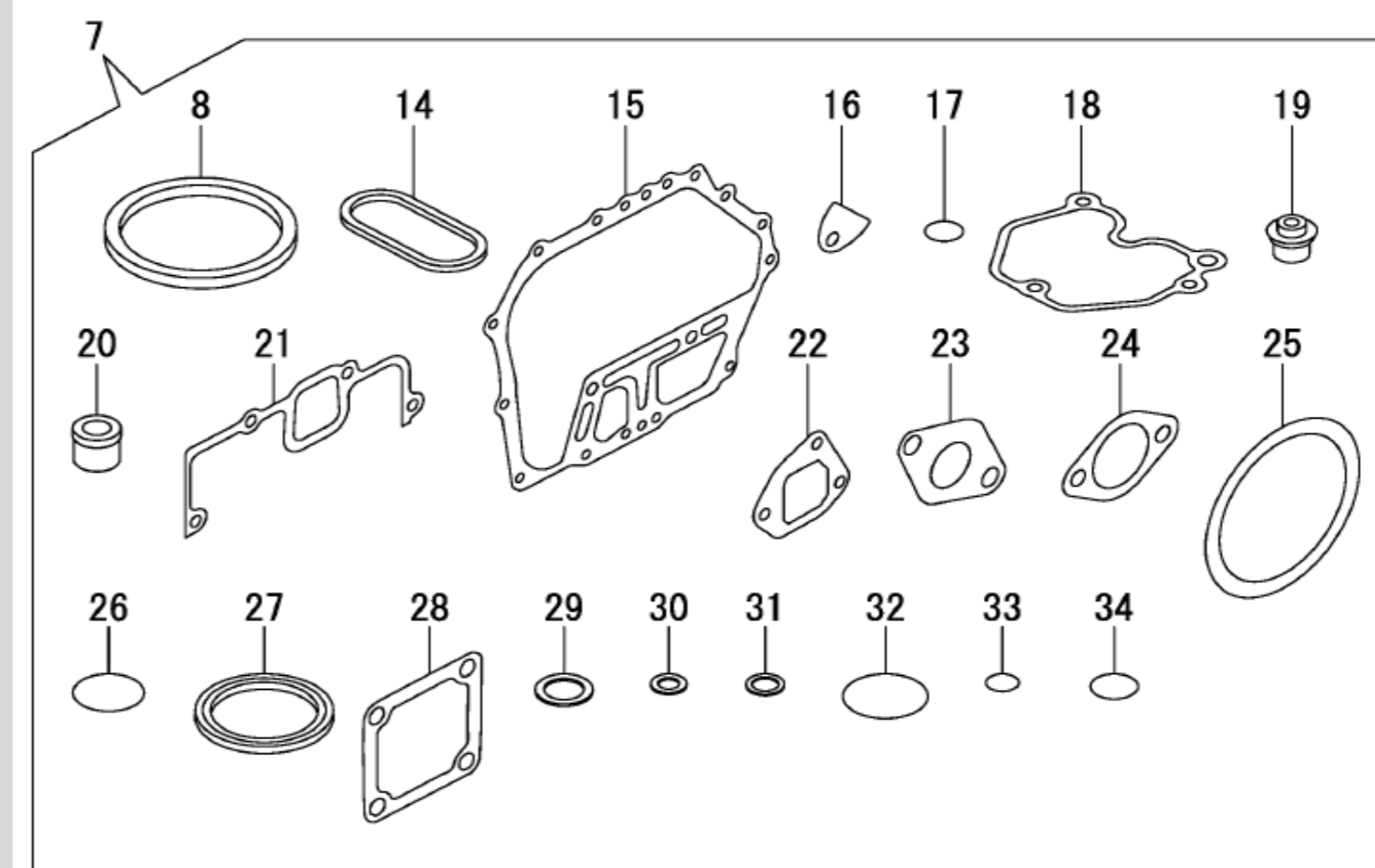
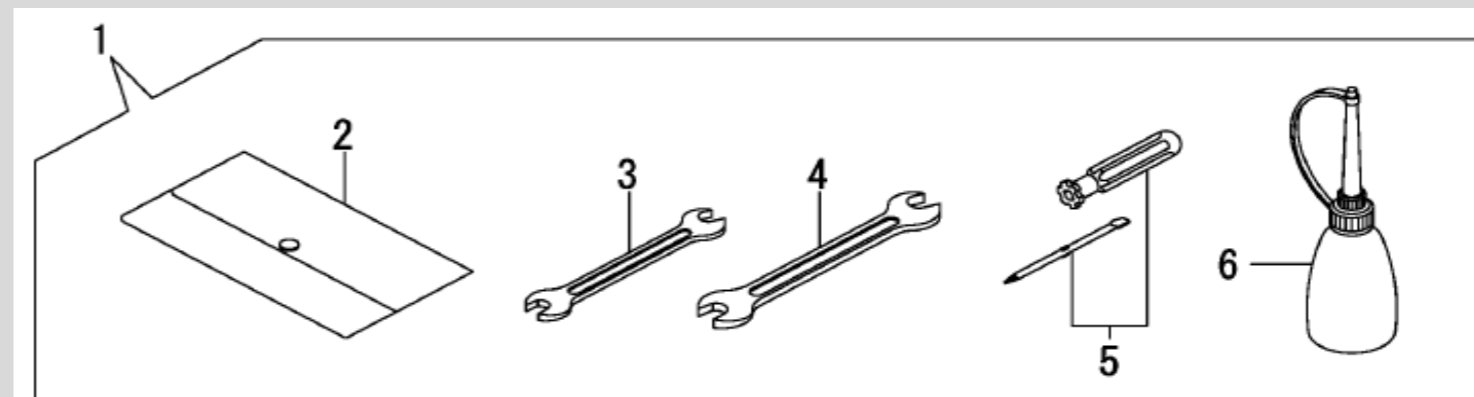

MOTEUR L100

13L TANK OPTION

N°	REF. FOURNISSEUR	DESCRIPTION	QUANTITE
1	183350-55120	PIN, FLAT HEAD 6X14	4
2	183350-55130	WASHER	4
3	114820-55900	TANK ASSY, FUEL OIL	1
4	114268-07240	LABEL, CAUTION	1
5	114268-07350	LABEL, HOW TO START	1
7	104200-55080	PLUG, DRAIN M12	1
8	22190-120002	WASHER, SEAL 12	1
9	160710-55061	CAP ASSY, FUEL TANK	1
16	160393-55050	GASKET	1
17	160710-55100	FILTER, FUEL	1
18	183254-55120	FILTER, FUEL	1
19	24341-000450	O-RING, 1A545.0	1
20	183621-55150	GAUGE, FUEL	1
21	183720-55210	GROMMET, TANK	4
22	114239-59010	PIPE ASSY, FUEL	1
23	106990-44660	CLAMP, HOSE 12.5	3
24	183250-59040	PIECE, PIPE	1
25	114239-59050	PIPE, FUEL OIL	1
26	114239-59160	PIPE ASSY, RETURN	1
27	124722-59050	CLAMP, HOSE 9	1
28	183984-59060	PIPE, FUEL RETURN	1
29	124066-59100	CLAMP, HOSE 8	1
30	22372-060000	PIN, SNAP 6	4
31	26366-060002	NUT, M6	3

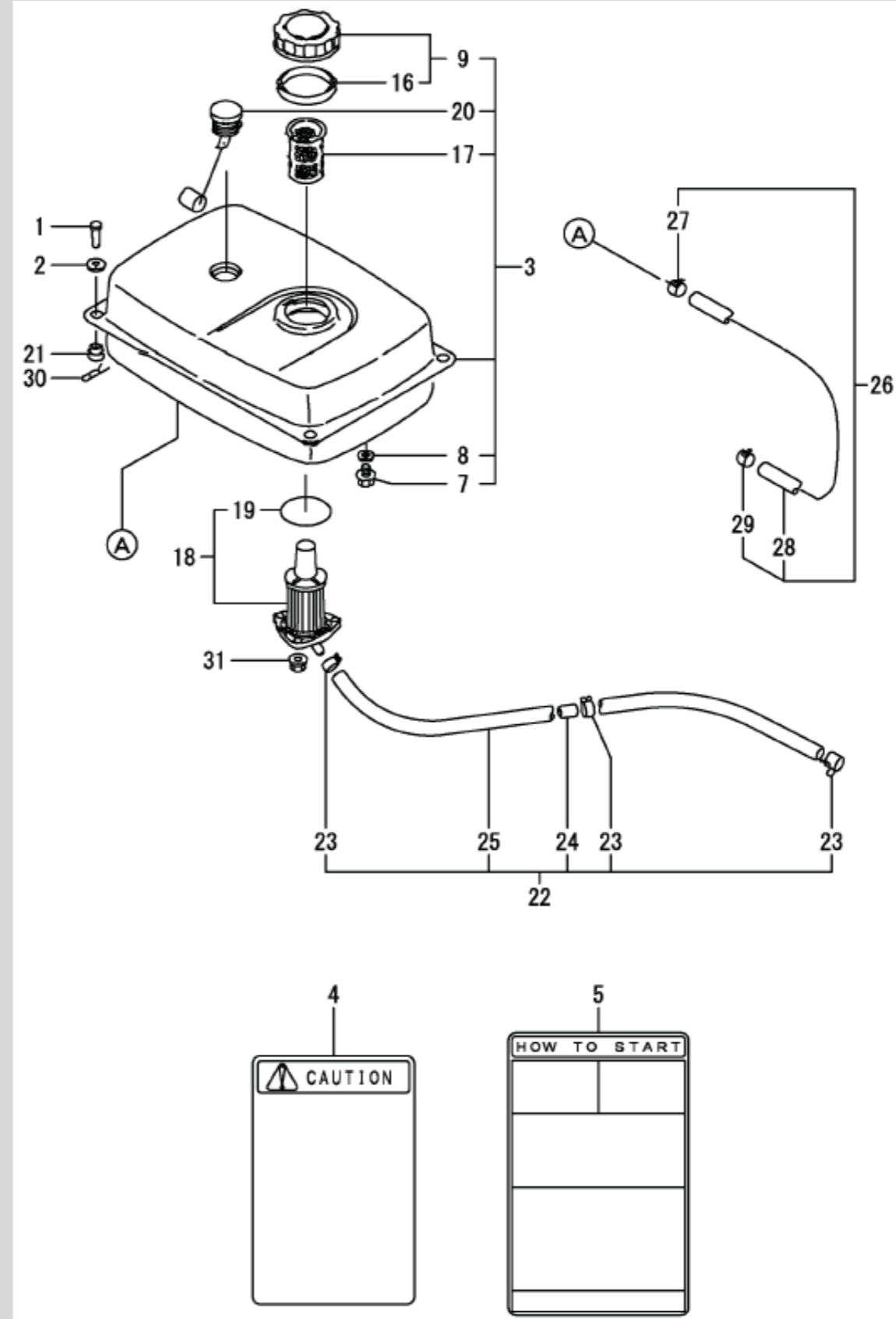

KIT BROUETTE

BROUETTE OPTION

N°	Référence NAV	Désignation NAV	QUANTITE
1	ZCADGMP01-A	CHASSIS GMP01	1
2	ZCADGMP01-F	AXE ROUE GMP01	2
3	ZCONTACTM8M	RONDELLE MOYENNE M8 ZBJ	6
4	ZVISTHM8X25	VIS TH M8*25 ZBJ	4
5	ZECROUM8T/1	ECROU M8 TWOLOCK ETROIT	5
6	ZRED430AG	ROUE DIAM 430 AGRAIRE	2
7	ZPLATEM24	RONDELLE PLATE M24 DIN 126	2
8	ZGOUP.FENDUES	GOUPILLE FENDUE 4*32 ZIN	2
9	ZCADGMP01-B	BRANCARD GMP01	1
10	ZCADGMP01-C	VERROU BRANCARD GMP01	1
11	ZCONTACTm6M	RONDELLE MOYENNE M6 ZBJ	6
12	ZVISBHCIM6X50	VIS BHC M6 X 50 INOX	3
13	ZECROUBAGM6	ECROU BAG NYLON M6 ZING	3
14	MER-900139	BUTEE PROG DP5050	1
15	ZCADGMP01-E	BEQUILLE GMP01	1
16	ZVISTHM8x20	VIS TH M8*20 ZBJ	2
17	ZCADGMP01-I	CALE BASCULE	1
18	ZGOUP.BETA	GOUPILLE BETA 4,5 ZBJ	1

